



鐸豐富企業有限公司
DOW FENG FUH ENTERPRICE CO., LTD.

捨棄式精密刀具

Disposal Precision Cutting Tools



專業設計製造廠 Specialized Design & Manufacturer

信賴的刀具品質 來自於嚴謹的檢驗

鐸豐富公司自從創立以來，所堅持的信念，就是為客戶提供最佳品質的刀具。無論是對於原物料之選擇、加工、處理等，我們都依據最高品質標準執行。

本公司之品管部門更擁有全系列精密檢驗儀器，針對每一支刀具作最嚴格的檢驗，以確保品質的完美。

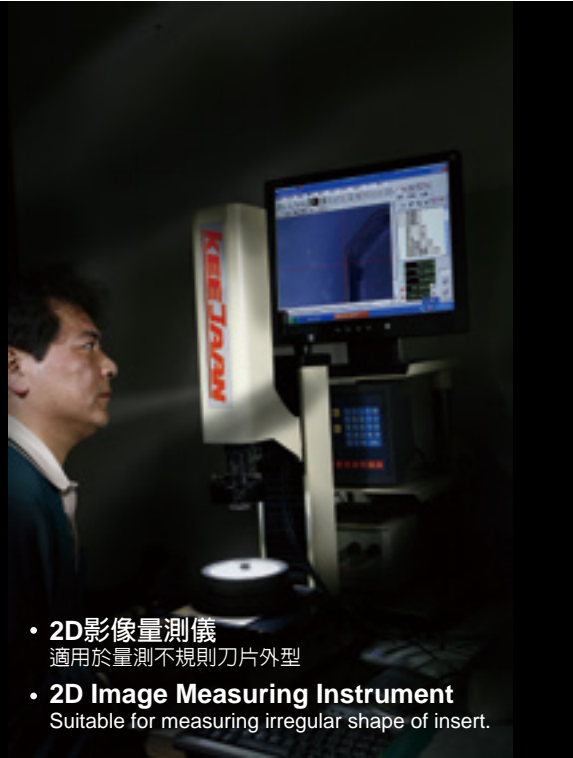

- 2D影像量測儀
適用於量測不規則刀片外型
- 2D Image Measuring Instrument
Suitable for measuring irregular shape of insert.



INDEX

	DDR P11~P17 快速鑽頭 HIGH SPEED DRILL		TDS P35 T型銑刀 T-SLOT MILLING CUTTER		TE90AX P44 鎖牙式直角高速銑刀 THREADED ORTHOGONAL HIGH SPEED MILLING CUTTER		UEX P52 鎖牙式直角銑刀 THREADED ORTHOGONAL MILLING CUTTER
	SDR P18~P24 快速鑽頭 HIGH SPEED DRILL		RTM P36 圓頭T型銑刀 ROUND HEAD T-SLOT MILLING CUTTER		TE903P P45 直角高速銑刀 ORTHOGONAL HIGH SPEED MILLING CUTTER		AHU P53 直角高速銑刀 ORTHOGONAL HIGH SPEED MILLING CUTTER
	WDR P25~P29 快速鑽頭 HIGH SPEED DRILL		SRE P37 高速粗銑刀 HIGH SPEED ROUGH MILLING CUTTER		TEBL P46 高速進給銑刀 HIGH SPEED FEED MILLING CUTTER 鎖牙式高速進給銑刀 THREADED HIGH SPEED FEED MILLING CUTTER		AJU P54 鑽銑刀 DRILLING & MILLING CUTTER
	TDR P30 快速鑽車刀 HIGH SPEED DRILL		DFW P38~P39 高速側銑三面刀 HIGH SPEED SIDE MILLING CUTTER		TEBL P47 殼型高速進給銑刀 SHELL TYPE HIGH SPEED FEED MILLING CUTTER		AJU P55 鎖牙式鑽銑刀 THREADED DRILLING & MILLING CUTTER
	SEM P31 直角高速銑刀 ORTHOGONAL HIGH SPEED MILLING CUTTER		DFC P40 殼型高速側銑三面刀 SHELL TYPE HIGH SPEED SIDE MILLING CUTTER		ASR P48 高速進給銑刀 HIGH SPEED FEED MILLING CUTTER		BCF P56 球型粗銑刀 BALL NOSE ROUGH MILLING CUTTER 鎖牙式球型粗銑刀 THREADED NOSE BALL ROUGH MILLING CUTTER
	SEC P32 殼型直角高速銑刀 SHELL TYPE ORTHOGONAL HIGH SPEED MILLING CUTTER		SRB P41 高速粗搪刀 HIGH SPEED ROUGH BORING CUTTER		ASR P49 鎖牙式高速進給銑刀 THREADED HIGH SPEED FEED MILLING CUTTER 殼型高速進給銑刀 SHELL TYPE HIGH SPEED FEED MILLING CUTTER		ABPF P57 精修球刀 FINISHING BALL NOSE MILLING CUTTER 鎖牙式精修球刀 THREADED FINISHING BALL NOSE MILLING CUTTER
	CDR P33 45°高速倒角刀 45° HIGH SPEED CHAMFERING CUTTER		DTB P42 定值粗搪刀 ROUGH BORING CUTTER		ASRFS/ASRFB P50 高速銑刀 HIGH SPEED MILLING CUTTER 殼型高速銑刀 SHELL TYPE HIGH SPEED MILLING CUTTER		ABRFM P58 鎖牙式精修圓鼻刀 THREADED FINISHING BALL MILLING CUTTER
	STM P34 高速T型刀 HIGH SPEED T-SLOT MILLING CUTTER		TE90AX P43 直角高速銑刀 ORTHOGONAL HIGH SPEED MILLING CUTTER		TDN P51 高速進給銑刀 HIGH SPEED FEED MILLING CUTTER 鎖牙式高速進給銑刀 THREADED HIGH SPEED FEED MILLING CUTTER		SPVM/SPVS P59 鎖牙式多功能銑刀 THREADED MULTI-FUNCTION MILLING CUTTER 多功能銑刀 MULTI-FUNCTION MILLING CUTTER

INDEX

	SBT P60 粗球刀 BALL NOSE ROUGH MILLING CUTTER		BAP P69 鎖牙式直角銑刀 THREADED ORTHOGAL MILLING CUTTER B T 整體式銑刀 BT MILLING CUTTER HOLDER		APX30R P78 高進給端銑刀 HIGH FEED END MILLING CUTTER		WEM P86 直角殼型面銑刀 SHELL TYPE ORTHOGONAL FACE MILLING CUTTER
	SKSD P61 殼型高速進給銑刀 SHELL TYPE HIGH SPEED FEED MILLING CUTTER		BAP P70 粗銑刀 ROUGH CUTTING MILLING CUTTER 殼型粗銑刀 SHELL TYPE ROUGH MILLING CUTTER		APX30R/APX30R P79 直角面銑刀 ORTHOGONAL FACE MILLING CUTTER B T 整體式銑刀 BT HOLDER MILLING CUTTER		WEXR P87~P88 直角端銑刀 ORTHOGONAL END MILLING CUTTER
	PPH / PPHT P62 精修球刀 FINISHING BALL NOSE MILLING CUTTER 精修圓鼻刀 FINISHING BALL MILLING CUTTER		RAP P71 殼型平面銑刀 SHELL TYPE FACE MILLING CUTTER		APX40R P80 直角銑刀 ORTHOGONAL MILLING CUTTER 直角面銑刀 ORTHOGONAL FACE MILLING CUTTER		WEXR P89 殼型直角端銑刀 SHELL TYPE ORTHOGONAL MILLING CUTTER
	PPH / PPHT P63 鎖牙式精修球刀 THREADED FINISHING BALL NOSE MILLING CUTTER 鎖牙式精修圓鼻刀 THREADED FINISHING BALL MILLING CUTTER		AQXR P72 短刃型鑽銑刀 SHORT INSERT DRILLING & MILLING CUTTER		HX640WR / HX640SR P81 殼型七角形平面銑刀 SHELL TYPE HEPTAGON FACE MILLING CUTTER		WEM / WEXR P90 B T 整體式銑刀 BT MILLING CUTTER HOLDER
	JXD P64 高速進給銑刀 HIGH FEED MILLING CUTTER 殼型高速進給銑刀 SHELL TYPE HIGH FEED MILLING CUTTER		AQXR P73 長刃型鑽銑刀 LONG INSERT DRILLING & MILLING CUTTER		DSX445 P82 殼型平面銑刀 SHELL TYPE FACE MILLING CUTTER		2280 P91 八角重切銑刀 OCTAGON HEAVY DUTY MILLING CUTTER
	BAP P65 直角鍵槽端銑刀 ORTHOGONAL KEYWAY END MILLING CUTTER		BRP P74~P75 圓刃端銑刀 ROUND INSERT END MILL 殼型圓刃面銑刀 SHELL TYPE ROUND INSERT FACE MILLING CUTTER		BXD15 P83 多功能端銑刀 MULTI-FUNCTION END MILL 殼型多功能銑刀 SHELL TYPE MULTI-FUNCTION MILLING CUTTER		4033 P92 45°殼型面銑刀 45° SHELL TYPE FACE MILLING CUTTER
	BAP P66~P67 直角端銑刀 ORTHOGONAL END MILLING CUTTER		ASX445R/L P76 45°右 / 左旋殼型平面銑刀 45° SHELL TYPE FACE MILLING CUTTER		FR P84 圓刃端銑刀 ROUND INSERT END MILL		4048 P93 88°殼型銑刀 88° SHELL TYPE MILLING CUTTER
	BAP P68 殼型直角面銑刀 SHELL TYPE ORTHOGONAL FACE MILLING CUTTER		ASX400R P77 直角端銑刀 ORTHOGONAL END MILLING CUTTER 殼型直角面銑刀 SHELL TYPE FACE MILLING CUTTER		WEM P85 直角銑刀 ORTHOGONAL MILLING CUTTER		SWES P94 鎖牙式高速重切削球刀 THREADED HIGH SPEED HEAVY CUTTING BALL NOSE MILLING CUTTER







INDEX

	2330 P95 高速重切削球刀 HIGH SPEED HEAVY CUTTING BALL NOSE MILLING CUTTER 殼型高速重切削球刀 SHELL TYPE HIGH SPEED HEAVY CUTTING BALL NOSE MILLING CUTTER		2139 P103~P104 精球刀 FINISHING BALL NOSE MILLING CUTTER 鎖牙式精修球刀 THREADED FINISHING BALL NOSE MILLING CUTTER		AP P112 鎖牙式直角銑刀 THREADED ORTHOGONAL MILLING CUTTER		CDM P120~P121 側銑刀 SIDE MILLING CUTTER
	4041 P96 直角銑刀 ORTHOGONAL MILLING CUTTER 直角殼型銑刀 SHELL TYPE ORTHOGONAL FACE MILLING CUTTER		MWE P105 鎖牙式多功能銑刀 THREADED MULTI-FUNCTION MILLING CUTTER 殼型多功能銑刀 SHELL TYPE MULTI-FUNCTION MILLING CUTTER 多功能倒角刀 MULTI-FUNCTION CHAMFERING CUTTER		AP10,16 P113 粗銑刀 ROUGH MILLING CUTTER 殼型粗銑刀 SHELL TYPE ROUGH MILLING CUTTER		GDM P122 殼型側銑刀 SHELL TYPE ORTHOGONAL MILLING CUTTER
	4042 P97 直角銑刀 ORTHOGONAL MILLING CUTTER 直角殼型銑刀 SHELL TYPE ORTHOGONAL MILLING CUTTER		MWC P106 端銑刀 HIGH SPEED FEED END MILLING CUTTER 鎖牙式端銑刀 THREADED HIGH SPEED FEED END MILLING CUTTER 殼型銑刀 SHELL TYPE HIGH SPEED FEED MILLING CUTTER		RP P114 圓刃銑刀 ROUND INSERT MILLING CUTTER 殼型圓刃銑刀 SHELL TYPE ROUND INSERT MILLING CUTTER		SN1205 P123 殼型刨削銑刀 SHELL TYPE PLANING MILLING CUTTER
	2038 P98 殼型粗銑刀 SHELL TYPE ROUGH MILLING CUTTER		MRD P107 圓刃銑刀 ROUND INSERT MILLING CUTTER		R390 P115 直角銑刀 ORTHOGONAL MILLING CUTTER		AKM P124 45° 殼型鋁合金銑刀 45° SHELL TYPE ALUMINUM ALLOY CUTTER
	SGP P99 88°殼型銑刀 88° SHELL TYPE MILLING CUTTER		MRD P108 殼型圓刃面銑刀 SHELL TYPE ROUND INSERT MILLING CUTTER		R390 P116 殼型直角銑刀 SHELL TYPE ORTHOGONAL MILLING CUTTER		AAP P125 殼型直角鋁合金銑刀 SHELL TYPE ORTHOGONAL ALUMINUM ALLOY CUTTER
	MRO P100 圓刃銑刀 ROUND INSERT MILLING CUTTER 殼型圓刃面銑刀 SHELL TYPE ROUND INSERT MILLING CUTTER		MRD P109 鎖牙式圓刃銑刀 THREADED ROUND INSERT MILLING CUTTER		R390 P117 鎖牙式直角銑刀 THREADED ORTHOGONAL MILLING CUTTER		SE445 P126 平面銑刀 FACE MILLING CUTTER
	MRO P101 鎖牙式圓刃銑刀 THREADED ROUND INSERT MILLING CUTTER		AP P110 直角銑刀 ORTHOGONAL MILLING CUTTER		R390 P118 粗銑刀 ROUGH MILLING CUTTER BT 整體式銑刀 BT HOLDER MILLING CUTTER		SE445R/L P127 45° 平面銑刀 45° FACE MILLING CUTTER
	2239 P102 粗球刀 BALL NOSE ROUGH END MILL		AP/AP10 P111 殼型直角銑刀 SHELL TYPE SHOULDER CUTTING MILLING CUTTER B T 整體式銑刀 BT SOLID MILLING CUTTER		XO P119 直角高速銑刀 ORTHOGONAL HIGH SPEED END MILL		SKE90 P128 直角銑刀 ORTHOGONAL MILLING CUTTER

INDEX

	SKE45/30/60 P129 斜度銑刀 TAPER MILLING CUTTER		MEC P137 直角高速銑刀 ORTHOGONAL HIGH SPEED MILLING CUTTER 鎖牙式高速銑刀 THREADED ORTHOGONAL HIGH SPEED MILLING CUTTER		BJ20 P144 替換式搪孔刀柄 INTERCHANGEABLE BORING BAR		ASP535/545 P152 殼型銑刀 SHELL TYPE MILLING CUTTER
	DC07,11 P130 斜度銑刀(鳩尾刀) DOVETAIL MILLING CUTTER 斜度殼型銑刀 SHELL TYPE TAPERED MILLING CUTTER		TFE P138 殼型輕量化銑刀 SHELL TYPE LIGHT DUTY MILLING CUTTER		TBB P145 替換式搪刀柄 REPLACEABLE BORING BAR		NSE400R P153 殼型直角面銑刀 SHELL TYPE ORTHOGNAL FACE MILLING CUTTER
	SST/SSA P131 定位倒角刀 POSITIONING CHAMFERING CUTTER		EXN03 P139 高速直角銑刀 ORTHOGONAL HIGH SPEED MILLING CUTTER 鎖牙式高速直角銑刀 THREADED ORTHOGONAL HIGH SPEED MILLING CUTTER		CBB P146 替換式搪刀柄 REPLACEABLE BORING BAR		HCN07 P154 高進給銑刀 HIGH FEED SPEED MILLING CUTTE 鎖牙式高進給銑刀 THREADED HIGH FEED SPEED MILLING CUTTER
	DBR P132 背搪刀 BACK BORING CUTTER		EPA/EVPA P140 高速銑刀 HIGH SPEED MILLING CUTTER 直角高速銑刀 ORTHOGONAL HIGH SPEED MILLING CUTTER		C211 P147 直角高速端銑刀 ORTHOGONAL HIGH SPEED END MILLING CUTTER		HHN P155 多角平面銑刀 MULTI-ANGLE FACE MILLING CUTTER
	MFH01 P133 殼型高進給銑刀 HIGH FEED MILLING CUTTER 鎖牙式高進給精修銑刀 THREADED HIGH FEED MILLING CUTTER		HFWX P141 高速銑刀 HIGH SPEED MILLING CUTTE 鎖牙式高速銑刀 THREADED HIGH SPEED MILLING CUTTER		ON05 P148 殼型八角型銑刀 SHELL TYPE OCTAGON MILLING CUTTER		PHN P156 殼型多角平面銑刀 MULTI-ANGLE FACE MILLING CUTTER
	MFH03 P134 高進給銑刀 HIGH FEED MILLING CUTTER 鎖牙式高進給銑刀 THREADED HIGH FEED MILLING CUTTER		RT07,10 P142 鎖牙式直角高速銑刀 THREADED ORTHOGONAL HIGH SPEED MILLING CUTTER 直角高速銑刀 ORTHOGONAL HIGH SPEED MILLING CUTTER		ASP415R P149 殼型銑刀 SHELL TYPE MILLING CUTTER 殼型多刃銑刀 SHELL TYPE MULTI-INSERT MILLING CUTTER		VSM11/490 P157 直角高速銑刀 ORTHOGONAL HIGH SPEED SHOLDER MILLING CUTTER
	MFH10 P135 高進給銑刀 HIGH FEED MILLING CUTTER 鎖牙式高進給銑刀 THREADED HIGH FEED MILLING CUTTER		ASD90/120 P143 定位倒角刀 POSITIONING & CHAMFERRING CUTTER		ASP435R P150 殼型銑刀 SHELL TYPE MILLING CUTTER 殼型多刃銑刀 SHELL TYPE MULTI-INSERT MILLING CUTTER		KHD P158 鎢鋼抗振接桿 TUNGSTEN CABIDE CONNECTION ROD
	MFH10 P136 殼型高進給銑刀 SHELL TYPE HIGH FEED MILLING CUTTER		BJ16 P144 替換式搪孔刀柄 INTERCHANGEABLE BORING BAR		ASE445R P151 殼型銑刀 SHELL TYPE MILLING CUTTER 殼型多刃銑刀 SHELL TYPE MULTI-INSERT MILLING CUTTER		KMC P159 連接式合金鋼接桿 TUNGSTEN CABIDE CONNECTION ROD

INDEX

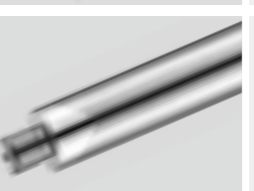
	BT 鎖牙接桿 ARBOR	P160~P161		
	SCFCR 卡式刀座 CARTRIDGES	P162		
	STFCR 卡式刀座 CARTRIDGES	P162		
	STSCR 卡式刀座 CARTRIDGES	P162		
	STWCR 卡式刀座 CARTRIDGES	P163		
	STTCR 卡式刀座 CARTRIDGES	P163		
	EB 捨棄式搪孔刀 DISPOSABLE BORING MILLING CUTTER	P164		
	SC 直束鎢鋼柄搪刀桿 STRAIGHT TUNGSTEN CARBIDE TOOL HOLDER	P165		

DDR 2D快速鑽頭 2D HIGH SPEED DRILL

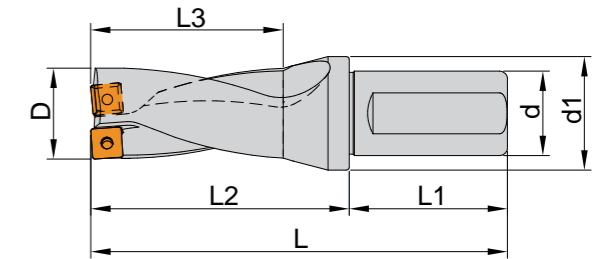
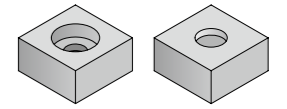

規格表 Specification

Unit: mm

型號 Model	D	d	d1	L	L3	L2	L1	刀片類型 Inserts	螺絲 Screw	板手 Wrench
DDR2125-20T2-05	12.5	20	27	94	26	44	50	SPMG050204	TS2003	T06
DDR2130-20T2-05	13									
DDR2135-20T2-05	13.5									
DDR2140-20T2-05	14									
DDR2145-20T2-05	14.5									
DDR2150-20T2-05	15									
DDR2155-25T2-06	15.5	25	33	108	32	52	56	SPMG060204	TS2205	T06
DDR2160-25T2-06	16									
DDR2165-25T2-06	16.5									
DDR2170-25T2-06	17									
DDR2175-25T2-06	17.5									
DDR2180-25T2-06	18									
DDR2185-25T2-06	18.5									
DDR2190-25T2-06	19									
DDR2195-25T2-06	19.5									
DDR2200-25T2-06	20									
DDR2205-25T2-06	20.5									
DDR2210-25T2-06	21									
DDR2215-25T2-06	21.5									
DDR2220-25T2-07	22	32	43	123	44	67	60	SPMG07T308	TS2511	T06
DDR2225-32T2-07	22.5									
DDR2230-32T2-07	23									
DDR2235-32T2-07	23.5									
DDR2240-32T2-07	24									
DDR2245-32T2-07	24.5									
DDR2250-32T2-07	25									
DDR2255-32T2-07	25.5									
DDR2260-32T2-07	26									

DDR 2D 快速鑽頭
2D HIGH SPEED DRILL

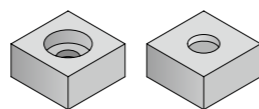
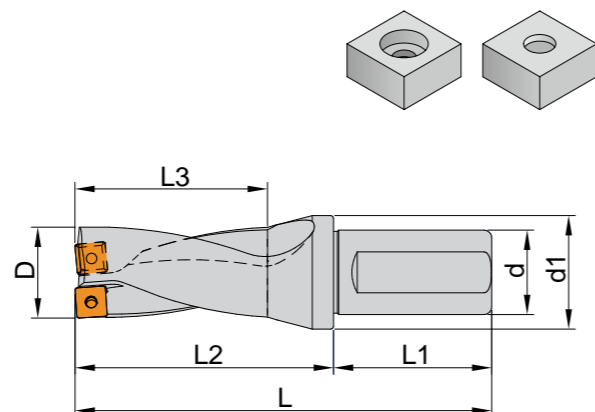

規格表 Specification

Unit: mm

型號 Model	D	d	d1	L	L3	L2	L1	刀片類型 Inserts	螺絲 Screw	板手 Wrench
DDR2265-32T2-07	26.5	32	43	142	54	81	60	SPMG07T308	TS2511	T08
DDR2270-32T2-07	27									
DDR2275-32T2-07	27.5									
DDR2280-32T2-09	28									
DDR2285-32T2-09	28.5									
DDR2290-32T2-09	29									
DDR2295-32T2-09	29.5									
DDR2300-32T2-09	30									
DDR2305-32T2-09	30.5									
DDR2310-32T2-09	31									
DDR2315-32T2-09	31.5	40	53	150	62	90	70	SPMG090408	TS3504	T15
DDR2320-32T2-09	32									
DDR2325-32T2-09	32.5									
DDR2330-32T2-09	33									
DDR2340-32T2-11	34									
DDR2350-32T2-11	35									
DDR2360-32T2-11	36									
DDR2370-32T2-11	37									
DDR2380-32T2-11	38									
DDR2390-32T2-11	39									
DDR2400-40T2-11	40	40	53	152	64	92	70	SPMG110408	TS4006	T15
DDR2410-40T2-11	41									
DDR2420-40T2-14	42									
DDR2430-40T2-14	43									
DDR2440-40T2-14	44									
DDR2450-40T2-14	45									
DDR2460-40T2-14	46									
DDR2470-40T2-14	47									
DDR2480-40T2-14	48									
DDR2490-40T2-14	49									
DDR2500-40T2-14	50	40	53	154	66	94	70	SPMG140512	TS5009	T20
DDR2340-32T2-11	34									
DDR2350-32T2-11	35									
DDR2360-32T2-11	36									
DDR2370-32T2-11	37									
DDR2380-32T2-11	38									
DDR2390-32T2-11	39									
DDR2400-40T2-11	40									
DDR2410-40T2-11	41									
DDR2420-40T2-14	42									

DDR 3D 快速鑽頭
3D HIGH SPEED DRILL

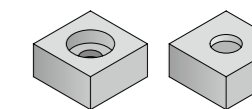
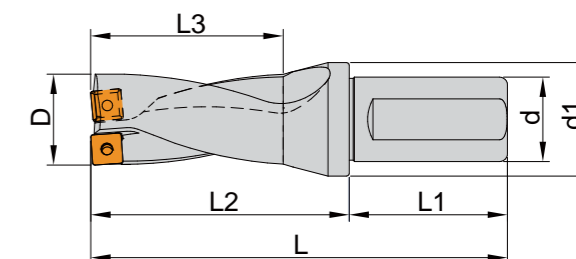

規格表 Specification

Unit: mm

型號 Model	D	d	d1	L	L3	L2	L1	刀片類型 Inserts	螺絲 Screw	板手 Wrench						
DDR3125-20T2-05	12.5	20	27	107	39	57	50	SPMG050204	TS2003	T06						
DDR3130-20T2-05	13															
DDR3135-20T2-05	13.5															
DDR3140-20T2-05	14															
DDR3145-20T2-05	14.5															
DDR3150-20T2-05	15															
DDR3155-25T2-06	15.5			25	33	124					48	68	56	SPMG060204	TS2205	T06
DDR3160-25T2-06	16															
DDR3165-25T2-06	16.5															
DDR3170-25T2-06	17															
DDR3175-25T2-06	17.5															
DDR3180-25T2-06	18															
DDR3185-25T2-06	18.5															
DDR3190-25T2-06	19															
DDR3195-25T2-06	19.5															
DDR3200-25T2-06	20	32	43			134	57	78	60	SPMG07T308	TS2511	T08				
DDR3205-25T2-06	20.5															
DDR3210-25T2-06	21															
DDR3215-25T2-06	21.5															
DDR3220-25T2-07	22															
DDR3225-32T2-07	22.5															
DDR3230-32T2-07	23															
DDR3235-32T2-07	23.5															
DDR3240-32T2-07	24															
DDR3245-32T2-07	24.5															
DDR3250-32T2-07	25	32	43	139	60	83	60	SPMG07T308	TS2511	T08						
DDR3255-32T2-07	25.5															
DDR3260-32T2-07	26															
DDR3265-32T2-07	26.5															

DDR 3D快速鑽頭
3D HIGH SPEED DRILL

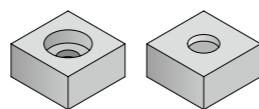
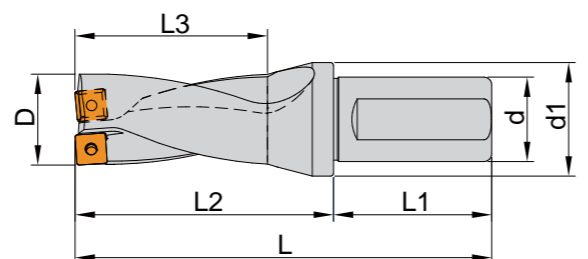

規格表 Specification

Unit: mm

型號 Model	D	d	d1	L	L3	L2	L1	刀片類型 Inserts	螺絲 Screw	板手 Wrench
DDR3265-32T2-07	26.5	32	43	169	81	108	60	SPMG07T308	TS2511	T08
DDR3270-32T2-07	27									
DDR3275-32T2-07	27.5									
DDR3280-32T2-09	28									
DDR3285-32T2-09	28.5									
DDR3290-32T2-09	29									
DDR3295-32T2-09	29.5									
DDR3300-32T2-09	30									
DDR3305-32T2-09	30.5									
DDR3310-32T2-09	31									
DDR3315-32T2-09	31.5	40	53	181	93	121	70	SPMG090408	TS3504	T15
DDR3320-32T2-09	32									
DDR3325-32T2-09	32.5									
DDR3330-32T2-09	33									
DDR3340-32T2-11	34									
DDR3350-32T2-11	35									
DDR3360-32T2-11	36									
DDR3370-32T2-11	37									
DDR3380-32T2-11	38									
DDR3390-32T2-11	39									
DDR3400-40T2-11	40	40	53	190	102	130	70	SPMG110408	TS4006	T15
DDR3410-40T2-11	41									
DDR3420-40T2-14	42									
DDR3430-40T2-14	43									
DDR3440-40T2-14	44									
DDR3450-40T2-14	45									
DDR3460-40T2-14	46									
DDR3470-40T2-14	47									
DDR3480-40T2-14	48									
DDR3490-40T2-14	49									
DDR3500-40T2-14	50			225	120	155				
				228	123	158				
				231	126	161				
				234	129	164				
				237	132	167				
				240	135	170				
				243	138	173				
				246	141	176				
				249	144	179				
				252	147	182				
				255	150	185				

DDR 4D快速鑽頭
4D HIGH SPEED DRILL

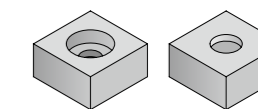
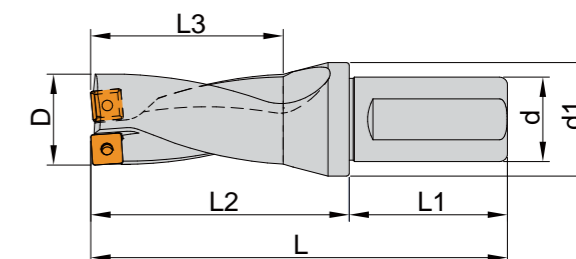

規格表 Specification

Unit: mm

型號 Model	D	d	d1	L	L3	L2	L1	刀片類型 Inserts	螺絲 Screw	板手 Wrench						
DDR4125-20T2-05	12.5	20	27	120	52	70	50	SPMG050204	TS2003	T06						
DDR4130-20T2-05	13															
DDR4135-20T2-05	13.5															
DDR4140-20T2-05	14															
DDR4145-20T2-05	14.5															
DDR4150-20T2-05	15															
DDR4155-25T2-06	15.5			25	33	140					64	84	56	SPMG060204	TS2205	T06
DDR4160-25T2-06	16															
DDR4165-25T2-06	16.5															
DDR4170-25T2-06	17															
DDR4175-25T2-06	17.5															
DDR4180-25T2-06	18															
DDR4185-25T2-06	18.5															
DDR4190-25T2-06	19															
DDR4195-25T2-06	19.5															
DDR4200-25T2-06	20	32	43			152	76	96	60	SPMG07T308	TS2511	T08				
DDR4205-25T2-06	20.5															
DDR4210-25T2-06	21															
DDR4215-25T2-06	21.5															
DDR4220-25T2-07	22															
DDR4225-32T2-07	22.5															
DDR4230-32T2-07	23															
DDR4235-32T2-07	23.5															
DDR4240-32T2-07	24															
DDR4245-32T2-07	24.5															
DDR4250-32T2-07	25	32	43	164	88	108	60	SPMG07T308	TS2511	T08						
DDR4255-32T2-07	25.5															
DDR4260-32T2-07	26															

DDR 4D 快速鑽頭
4D HIGH SPEED DRILL

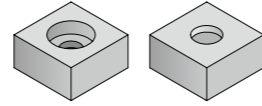
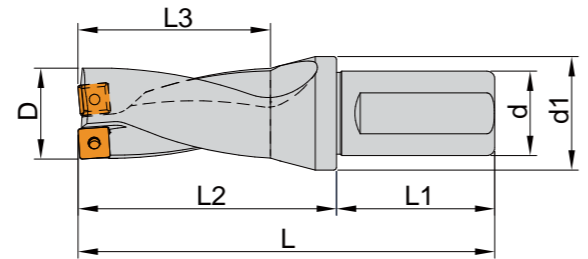

規格表 Specification

Unit: mm

型號 Model	D	d	d1	L	L3	L2	L1	刀片類型 Inserts	螺絲 Screw	板手 Wrench
DDR4265-32T2-07	26.5	32	43	196	108	136	60	SPMG07T308	TS2511	T08
DDR4270-32T2-07	27									
DDR4275-32T2-07	27.5									
DDR4280-32T2-09	28			200	112	140				
DDR4285-32T2-09	28.5									
DDR4290-32T2-09	29			204	116	144				
DDR4295-32T2-09	29.5									
DDR4300-32T2-09	30			208	120	148				
DDR4305-32T2-09	30.5									
DDR4310-32T2-09	31			212	124	152				
DDR4315-32T2-09	31.5									
DDR4320-32T2-09	32	216	128	156						
DDR4325-32T2-09	32.5									
DDR4330-32T2-09	33	220	132	160						
DDR4340-32T2-11	34									
DDR4350-32T2-11	35	224	136	164						
DDR4360-32T2-11	36									
DDR4370-32T2-11	37	228	140	168						
DDR4380-32T2-11	38									
DDR4390-32T2-11	39	232	144	172						
DDR4400-40T2-11	40									
DDR4410-40T2-11	41	236	148	176						
DDR4420-40T2-14	42									
DDR4430-40T2-14	43	240	152	180						
DDR4440-40T2-14	44									
DDR4450-40T2-14	45	244	156	184						
DDR4460-40T2-14	46									
DDR4470-40T2-14	47	248	160	188						
DDR4480-40T2-14	48									
DDR4490-40T2-14	49	252	164	192						
DDR4500-40T2-14	50									
DDR4430-40T2-14	43	40	53	273	168	203	70	SPMG110408	TS4006	T15
DDR4440-40T2-14	44									
DDR4450-40T2-14	45									
DDR4460-40T2-14	46			277	172	207				
DDR4470-40T2-14	47									
DDR4480-40T2-14	48			281	176	211				
DDR4490-40T2-14	49									
DDR4500-40T2-14	50			285	180	215				
DDR4430-40T2-14	43									
DDR4440-40T2-14	44			289	184	219				
DDR4450-40T2-14	45									
DDR4460-40T2-14	46	293	188	223						
DDR4470-40T2-14	47									
DDR4480-40T2-14	48	297	192	227						
DDR4490-40T2-14	49									
DDR4500-40T2-14	50	301	196	231						
DDR4430-40T2-14	43									
DDR4440-40T2-14	44	305	200	235						
DDR4450-40T2-14	45									

DDR 5D 快速鑽頭
5D HIGH SPEED DRILL

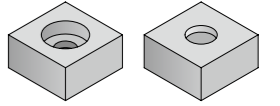
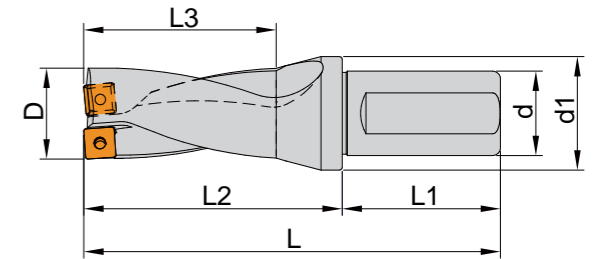

規格表 Specification

Unit: mm

型號 Model	D	d	d1	L	L3	L2	L1	刀片類型 Inserts	螺絲 Screw	板手 Wrench
DDR5130-20T2-05	13	20	27	133	65	83	50	SPMG050204	TS2003	T06
DDR5140-20T2-05	14									
DDR5150-20T2-05	15									
DDR5160-25T2-06	16	25	33	156	80	100	56	SPMG060204	TS2205	T06
DDR5170-25T2-06	17									
DDR5180-25T2-06	18									
DDR5190-25T2-06	19									
DDR5200-25T2-06	20									
DDR5210-25T2-06	21									
DDR5220-25T2-07	22	32	43	186	110	130	60	SPMG07T308	TS2511	T08
DDR5230-32T2-07	23									
DDR5240-32T2-07	24									
DDR5250-32T2-07	25									
DDR5260-32T2-07	26									
DDR5270-32T2-07	27									
DDR5280-32T2-09	28									
DDR5290-32T2-09	29									
DDR5300-32T2-09	30									
DDR5310-32T2-09	31									
DDR5320-32T2-09	32	40	53	210	125	150	70	SPMG090408	TS3504	T15
DDR5330-32T2-09	33									
DDR5340-32T2-11	34									
DDR5350-32T2-11	35									
DDR5360-32T2-11	36									
DDR5440-40T2-14	44									
DDR5230-32T2-07	23	40	53	200	115	140	70	SPMG110408	TS4006	T15
DDR5240-32T2-07	24									
DDR5250-32T2-07	25									
DDR5260-32T2-07	26									
DDR5270-32T2-07	27									
DDR5280-32T2-09	28									
DDR5290-32T2-09	29									
DDR5300-32T2-09	30									
DDR5310-32T2-09	31									
DDR5320-32T2-09	32									
DDR5330-32T2-09	33	44	53	228	140	168	70	SPMG140512	TS5009	T20
DDR5340-32T2-11	34									
DDR5350-32T2-11	35									
DDR5360-32T2-11	36									
DDR5440-40T2-14	44									
DDR5440-40T2-14	44									

SDR 2D快速鑽頭
2D HIGH SPEED DRILL

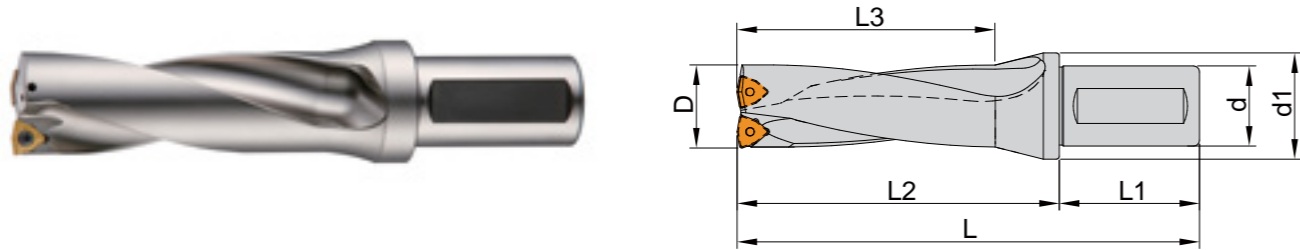
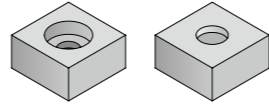

規格表 Specification

Unit: mm

型號 Model	D	d	d1	L	L3	L2	L1	刀片類型 Inserts	螺絲 Screw	板手 Wrench
SDR2140-25T2-03	14	25	38	114	28	58	56	WCMT030208	TS2502	T08
SDR2145-25T2-03	14.5									
SDR2150-25T2-03	15									
SDR2155-25T2-03	15.5									
SDR2160-25T2-03	16									
SDR2165-25T2-03	16.5									
SDR2170-25T2-03	17			120	34	64				
SDR2175-25T2-03	17.5									
SDR2180-25T2-03	18									
SDR2185-25T2-03	18.5									
SDR2190-25T2-03	19									
SDR2195-25T2-03	19.5									
SDR2200-25T2-03	20	126	40	70						
SDR2205-25T2-03	20.5									
SDR2210-25T2-04	21									
SDR2215-25T2-04	21.5									
SDR2220-25T2-04	22									
SDR2225-25T2-04	22.5									
SDR2230-25T2-04	23	138	46	78						
SDR2235-25T2-04	23.5									
SDR2240-25T2-04	24									
SDR2245-25T2-04	24.5									
SDR2250-25T2-04	25									
SDR2255-25T2-04	25.5									
SDR2260-25T2-05	26	32	43	142	50	82	60	WCMT040208	TS2507	T15
SDR2270-25T2-05	27									
SDR2280-25T2-05	28									
SDR2290-25T2-05	29									
SDR2300-25T2-05	30									

SDR 2D快速鑽頭
2D HIGH SPEED DRILL

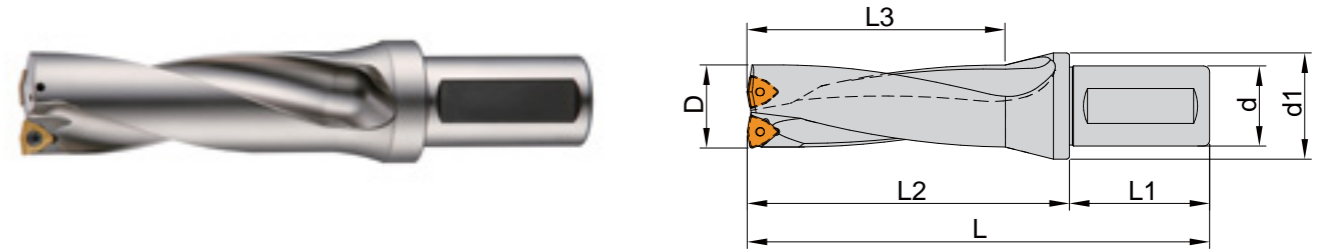
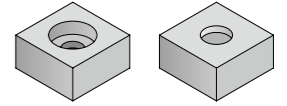

規格表 Specification

Unit: mm

型號 Model	D	d	d1	L	L3	L2	L1	刀片類型 Inserts	螺絲 Screw	板手 Wrench
SDR2310-32T2-06	31	32	43	154	62	94	60	WCMT06T308	TS3501	T15
SDR2320-32T2-06	32									
SDR2330-32T2-06	33									
SDR2340-32T2-06	34									
SDR2350-32T2-06	35									
SDR2360-32T2-06	36									
SDR2370-32T2-06	37			166	74	106				
SDR2380-32T2-06	38									
SDR2390-32T2-06	39									
SDR2400-40T2-06	40									
SDR2410-40T2-06	41									
SDR2420-40T2-08	42									
SDR2430-40T2-08	43	189	84	119						
SDR2440-40T2-08	44									
SDR2450-40T2-08	45									
SDR2460-40T2-08	46									
SDR2470-40T2-08	47									
SDR2480-40T2-08	48									
SDR2490-40T2-08	49	202	98	132						
SDR2500-40T2-08	50									
SDR2510-40T2-08	51									
SDR2520-40T2-08	52									
SDR2530-40T2-08	53									
SDR2540-40T2-08	54									
SDR2550-40T2-08	55	215	110	145						
SDR2560-40T2-08	56									
SDR2570-40T2-08	57									
SDR2580-40T2-08	58									
SDR2590-40T2-08	59									
SDR2600-40T2-08	60									

SDR 3D快速鑽頭
3D HIGH SPEED DRILL

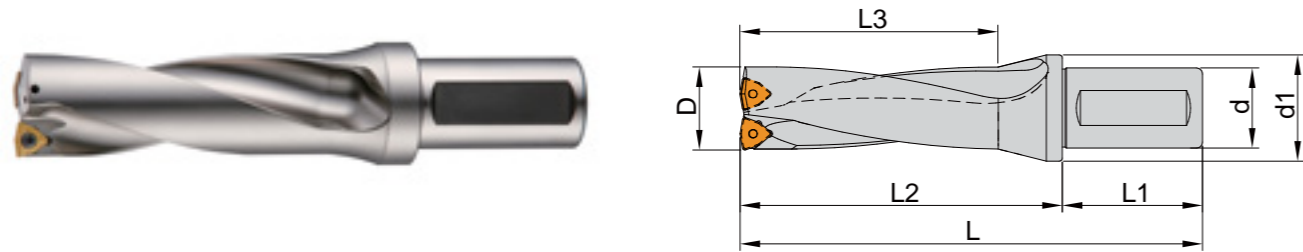
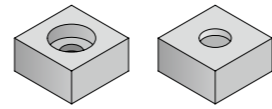

規格表 Specification

Unit: mm

型號 Model	D	d	d1	L	L3	L2	L1	刀片類型 Inserts	螺絲 Screw	板手 Wrench					
SDR3140-25T2-03	14	25	38	128	42	72	56	WCMT030208	TS2502	T08					
SDR3145-25T2-03	14.5														
SDR3150-25T2-03	15														
SDR3155-25T2-03	15.5														
SDR3160-25T2-03	16														
SDR3165-25T2-03	16.5														
SDR3170-25T2-03	17														
SDR3175-25T2-03	17.5														
SDR3180-25T2-03	18														
SDR3185-25T2-03	18.5														
SDR3190-25T2-03	19														
SDR3195-25T2-03	19.5														
SDR3200-25T2-03	20														
SDR3205-25T2-03	20.5														
SDR3210-25T2-04	21			32	43	158			66		98	60	WCMT040208	TS2507	T15
SDR3220-32T2-04	22														
SDR3225-32T2-04	22.5														
SDR3230-32T2-04	23														
SDR3235-32T2-04	23.5														
SDR3240-32T2-04	24														
SDR3245-32T2-04	24.5														
SDR3250-32T2-04	25														
SDR3255-32T2-04	25.5														
SDR3260-32T2-05	26														
SDR3270-32T2-05	27														
SDR3280-32T2-05	28														
SDR3290-32T2-05	29														
SDR3300-32T2-05	30														
SDR3305-32T2-06	30.5														
SDR3310-32T2-06	31														

SDR 3D快速鑽頭
3D HIGH SPEED DRILL

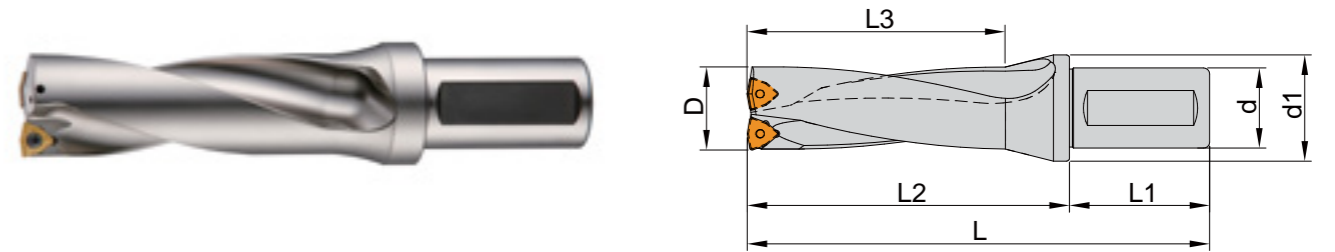
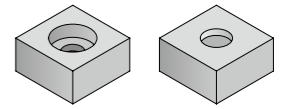

規格表 Specification

Unit: mm

型號 Model	D	d	d1	L	L3	L2	L1	刀片類型 Inserts	螺絲 Screw	板手 Wrench					
SDR3315-32T2-06	31.5	32	43	185	93	125	60	WCMT06T308	TS3501	T15					
SDR3320-32T2-06	32														
SDR3325-32T2-06	32.5														
SDR3330-32T2-06	33														
SDR3340-32T2-06	34														
SDR3350-32T2-06	35														
SDR3360-32T2-06	36														
SDR3370-32T2-06	37														
SDR3380-32T2-06	38														
SDR3390-32T2-06	39														
SDR3400-40T2-06	40			40	54	225					120	155	70	WCMT080412	TS4004
SDR3410-40T2-06	41														
SDR3420-40T2-08	42														
SDR3430-40T2-08	43														
SDR3440-40T2-08	44														
SDR3450-40T2-08	45														
SDR3460-40T2-08	46														
SDR3470-40T2-08	47														
SDR3480-40T2-08	48														
SDR3490-40T2-08	49														
SDR3500-40T2-08	50														
SDR3510-40T2-08	51														
SDR3520-40T2-08	52														
SDR3530-40T2-08	53														
SDR3540-40T2-08	54														
SDR3550-40T2-08	55														
SDR3560-40T2-08	56														
SDR3570-40T2-08	57														
SDR3580-40T2-08	58														
SDR3590-40T2-08	59														
SDR3600-40T2-08	60														

SDR 4D快速鑽頭
4D HIGH SPEED DRILL

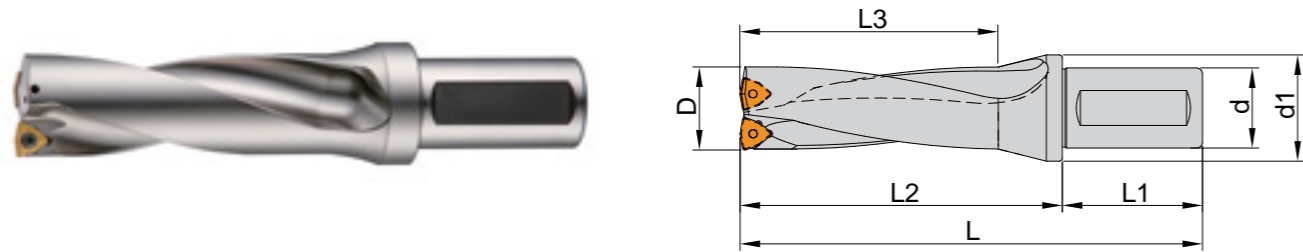
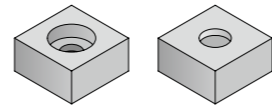

規格表 Specification

Unit: mm

型號 Model	D	d	d1	L	L3	L2	L1	刀片類型 Inserts	螺絲 Screw	板手 Wrench
SDR4140-25T2-03	14	25	38	142	56	86	56	WCMT080412	TS2502	T08
SDR4150-25T2-03	15			146	60	90				
SDR4160-25T2-03	16			150	64	94				
SDR4170-25T2-03	17			154	68	98				
SDR4180-25T2-03	18			158	72	102				
SDR4190-25T2-03	19			162	76	106				
SDR4200-25T2-03	20			166	80	110				
SDR4210-25T2-04	21			170	84	114				
SDR4220-32T2-04	22	32	43	180	88	120	60	WCMT040208	TS2507	T10
SDR4230-32T2-04	23			184	92	124				
SDR4240-32T2-04	24			188	96	128				
SDR4250-32T2-04	25			192	100	132				
SDR4260-32T2-05	26			196	104	136				
SDR4270-32T2-05	27			200	108	140				
SDR4280-32T2-05	28			204	112	144				
SDR4290-32T2-05	29			208	116	148				
SDR4300-32T2-05	30			212	120	152				
SDR4310-32T2-06	31			216	124	156				
SDR4320-32T2-06	32	32	43	220	128	160	60	WCMT050308	TS3007	T15
SDR4330-32T2-06	33			224	132	164				
SDR4340-32T2-06	34			228	136	168				
SDR4350-32T2-06	35			232	140	172				
SDR4360-32T2-06	36			236	144	176				
SDR4370-32T2-06	37			240	148	180				
SDR4380-32T2-06	38			40	54	244				
SDR4390-32T2-06	39	248	156			188				
SDR4400-32T2-06	40	265	160			195				
SDR4410-32T2-06	41	269	164			199				
SDR4420-40T2-08	42	273	168			203				
SDR4430-40T2-08	43	277	172			207				
SDR4440-40T2-08	44	282	176			212				
SDR4450-40T2-08	45	285	180			215				
SDR4460-40T2-08	46	289	184			219				
SDR4470-40T2-08	47	293	188			223				
SDR4480-40T2-08	48	297	192			227				
SDR4490-40T2-08	49	301	196			231				
SDR4500-40T2-08	50	305	200	235						
SDR4510-40T2-08	51	309	204	239						
SDR4520-40T2-08	52	313	208	243						
SDR4530-40T2-08	53	317	212	247						
SDR4540-40T2-08	54	320	216	250						
SDR4550-40T2-08	55	325	220	255						
SDR4560-40T2-08	56	58	329	224	259					
SDR4570-40T2-08	57		333	228	263					
SDR4580-40T2-08	58		337	232	267					
SDR4590-40T2-08	59	59	341	236	271					
SDR4600-40T2-08	60		345	240	275					

SDR 4D快速鑽頭
4D HIGH SPEED DRILL

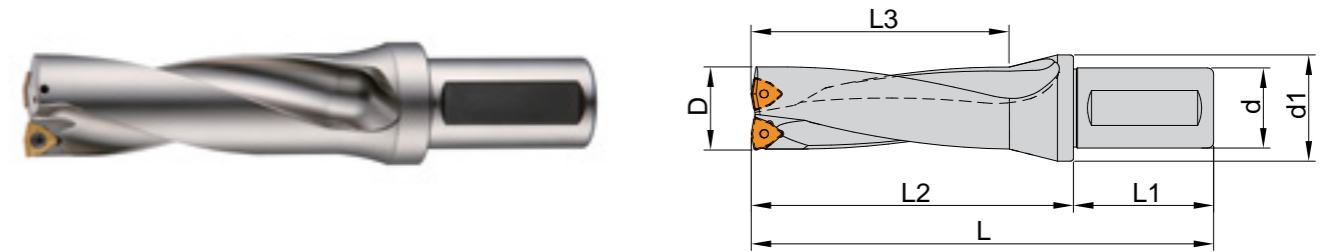
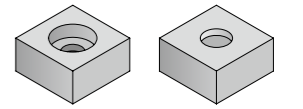

規格表 Specification

Unit: mm

型號 Model	D	d	d1	L	L3	L2	L1	刀片類型 Inserts	螺絲 Screw	板手 Wrench
SDR4380-32T2-06	38	32	43	244	152	184	60	WCMT06T308	TS3501	T15
SDR4390-32T2-06	39			248	156	188				
SDR4400-32T2-06	40			265	160	195				
SDR4410-32T2-06	41	40	54	269	164	199	70	WCMT080412	TS4004	T15
SDR4420-40T2-08	42			273	168	203				
SDR4430-40T2-08	43			277	172	207				
SDR4440-40T2-08	44			282	176	212				
SDR4450-40T2-08	45			285	180	215				
SDR4460-40T2-08	46			289	184	219				
SDR4470-40T2-08	47			293	188	223				
SDR4480-40T2-08	48			297	192	227				
SDR4490-40T2-08	49			301	196	231				
SDR4500-40T2-08	50			305	200	235				
SDR4510-40T2-08	51			309	204	239				
SDR4520-40T2-08	52			313	208	243				
SDR4530-40T2-08	53	317	212	247						
SDR4540-40T2-08	54	320	216	250						
SDR4550-40T2-08	55	325	220	255						
SDR4560-40T2-08	56	58	329	224	259					
SDR4570-40T2-08	57		333	228	263					
SDR4580-40T2-08	58		337	232	267					
SDR4590-40T2-08	59	59	341	236	271					
SDR4600-40T2-08	60		345	240	275					

SDR 5D 快速鑽頭
5D HIGH SPEED DRILL

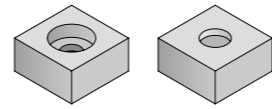
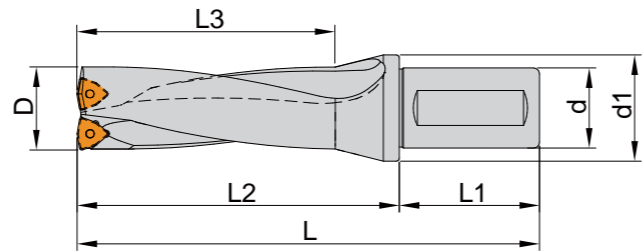

規格表 Specification

Unit: mm

型號 Model	D	d	d1	L	L3	L2	L1	刀片類型 Inserts	螺絲 Screw	板手 Wrench
SDR5160-25T2-03	16	25	38	166	80	110	56	WCMT030208	TS2507	T08
SDR5170-25T2-03	17			171	85	115				
SDR5180-25T2-03	18			176	90	120				
SDR5190-25T2-03	19			181	95	125				
SDR5200-25T2-03	20			186	100	130				
SDR5210-25T2-03	21			191	105	135				
SDR5220-25T2-03	22	32	43	196	110	140	60	WCMT040208	TS2507	T08
SDR5230-32T2-04	23			207	115	147				
SDR5240-32T2-04	24			212	120	152				
SDR5250-32T2-04	25			217	125	157				
SDR5260-32T2-05	26			222	130	162				
SDR5270-32T2-05	27			227	135	167				
SDR5280-32T2-05	28			232	140	172				
SDR5290-32T2-05	29			237	145	177				
SDR5300-32T2-05	30			242	150	182				
SDR5310-32T2-06	31			247	155	187				
SDR5320-32T2-06	32	40	54	252	160	192	70	WCMT06T308	TS3501	T15
SDR5330-32T2-06	33			257	165	197				
SDR5340-32T2-06	34			262	170	202				
SDR5350-32T2-06	35			267	175	207				
SDR5360-32T2-06	36			272	180	212				
SDR5440-32T2-08	44			326	220	256				

WDR 3D 快速鑽頭
3D HIGH SPEED DRILL

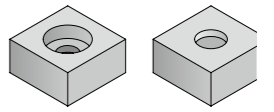
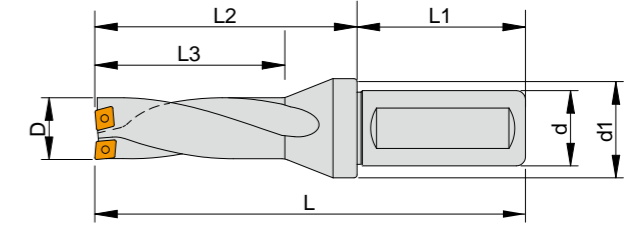

規格表 Specification

Unit: mm

型號 Model	D	d	d1	L	L3	L2	L1	刀片類型 Inserts	螺絲 Screw	板手 Wrench
WDR3130-20T2-04	13	20	27	107	39	57	50	WDXT042004	TS1801	T06
WDR3135-20T2-04	13.5			110	42	60				
WDR3140-20T2-04	14			114	45	64				
WDR3145-20T2-04	14.5			117	48	67				
WDR3150-20T2-04	15			120	51	70				
WDR3155-20T2-05	15.5			123	54	73				
WDR3160-20T2-05	16			126	57	76				
WDR3165-20T2-05	16.5			129	60	79				
WDR3170-20T2-05	17			132	63	82				
WDR3175-20T2-05	17.5			135	66	85				
WDR3180-20T2-05	18	25	33	143	63	87	56	WDXT063006	TS2203	T07
WDR3185-20T2-06	18.5			146	66	90				
WDR3190-20T2-06	19			149	69	93				
WDR3195-20T2-06	19.5			152	72	96				
WDR3200-20T2-06	20			155	75	99				
WDR3205-25T2-06	20.5			158	78	102				
WDR3210-25T2-06	21			161	81	105				
WDR3215-25T2-06	21.5			164	84	108				
WDR3220-25T2-06	22			167	87	111				
WDR3225-32T2-06	22.5			170	90	114				
WDR3230-32T2-07	23	40	54	173	93	117	60	WDXT073506	TS2511	T08
WDR3235-32T2-07	23.5			176	96	120				
WDR3240-32T2-07	24			179	99	123				
WDR3245-32T2-07	24.5			182	102	126				
WDR3250-32T2-07	25			185	105	129				
WDR3255-32T2-07	25.5			188	108	132				
WDR3260-32T2-07	26			191	111	135				
WDR3265-32T2-07	26.5			194	114	138				
WDR3270-32T2-07	27	197	117	141						

WDR 3D 快速鑽頭
3D HIGH SPEED DRILL

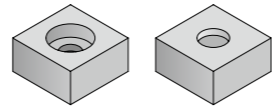
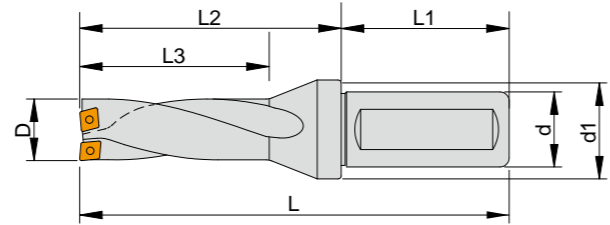

規格表 Specification

Unit: mm

型號 Model	D	d	d1	L	L3	L2	L1	刀片類型 Inserts	螺絲 Screw	板手 Wrench
WDR3275-32T2-07	27.5	32	43	172	84	112	60	WDXT073506	TS2511	T08
WDR3280-32T2-07	28									
WDR3285-32T2-07	28.5									
WDR3290-32T2-09	29			175	87	115				
WDR3295-32T2-09	29.5									
WDR3300-32T2-09	30									
WDR3305-32T2-09	30.5			181	93	121				
WDR3310-32T2-09	31									
WDR3315-32T2-09	31.5									
WDR3320-32T2-09	32			184	96	124				
WDR3325-32T2-09	32.5									
WDR3330-32T2-09	33									
WDR3340-32T2-09	34	187	99	127						
WDR3350-32T2-09	35									
WDR3360-32T2-09	36									
				190	102	130	WDXT094008	TS3510	T15	
				193	105	133				
				196	108	136				

WDR 4D 快速鑽頭
4D HIGH SPEED DRILL

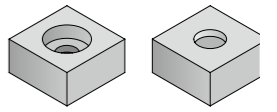
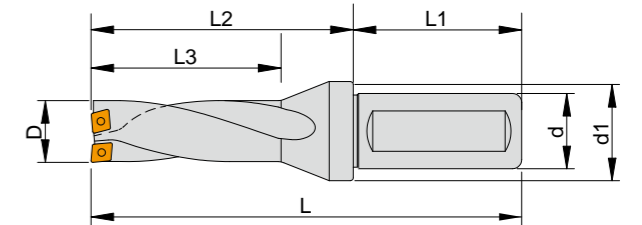

規格表 Specification

Unit: mm

型號 Model	D	d	d1	L	L3	L2	L1	刀片類型 Inserts	螺絲 Screw	板手 Wrench
WDR4130-20T2-04	13	20	27	120	52	70	50	WDXT042004	TS1801	T06
WDR4135-20T2-04	13.5									
WDR4140-20T2-04	14									
WDR4145-20T2-04	14.5			129	60	79				
WDR4150-20T2-04	15									
WDR4155-20T2-05	15.5									
WDR4160-20T2-05	16			133	64	83				
WDR4165-20T2-05	16.5									
WDR4170-20T2-05	17									
WDR4175-20T2-05	17.5			141	72	91				
WDR4180-20T2-05	18									
WDR4185-20T2-06	18.5									
WDR4190-20T2-06	19	145	76	95						
WDR4195-20T2-06	19.5									
WDR4200-20T2-06	20									
WDR4205-25T2-06	20.5	25	33	164	63	108	56	WDXT063006	TS2203	T07
WDR4210-25T2-06	21									
WDR4215-25T2-06	21.5									
WDR4220-25T2-06	22			172	69	116				
WDR4225-25T2-06	22.5									
WDR4230-25T2-07	23									
WDR4235-25T2-07	23.5			176	72	120				
WDR4240-25T2-07	24									
WDR4245-25T2-07	24.5									
WDR4250-25T2-07	25			180	75	124				
WDR4255-32T2-07	25.5									
WDR4260-32T2-07	26									
WDR4265-32T2-07	26.5	32	43	191	78	131	60	WDXT073506	TS2511	T08
WDR4270-32T2-07	27									

WDR 4D 快速鑽頭 4D HIGH SPEED DRILL

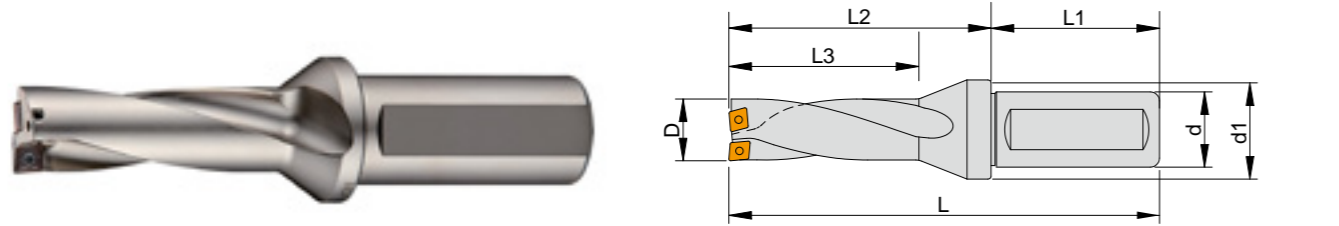

規格表 Specification

Unit: mm

型號 Model	D	d	d1	L	L3	L2	L1	刀片類型 Inserts	螺絲 Screw	板手 Wrench
WDR4275-32T2-07	27.5	32	43	200	84	140	60	WDXT073506	TS2511	T08
WDR4280-32T2-07	28									
WDR4285-32T2-07	28.5									
WDR4290-32T2-09	29			204	87	144				
WDR4295-32T2-09	29.5									
WDR4300-32T2-09	30									
WDR4305-32T2-09	30.5			212	93	152				
WDR4310-32T2-09	31									
WDR4315-32T2-09	31.5									
WDR4320-32T2-09	32			216	96	156				
WDR4325-32T2-09	32.5									
WDR4330-32T2-09	33									
WDR4340-32T2-09	34			224	102	164				
WDR4350-32T2-09	35									
WDR4360-32T2-09	36									
WDR4360-32T2-09	36			228	105	168				
WDR4360-32T2-09	36									
WDR4360-32T2-09	36									
WDR4360-32T2-09	36	232	108	172						
WDR4360-32T2-09	36									
WDR4360-32T2-09	36									

WDR 5D 快速鑽頭 5D HIGH SPEED DRILL

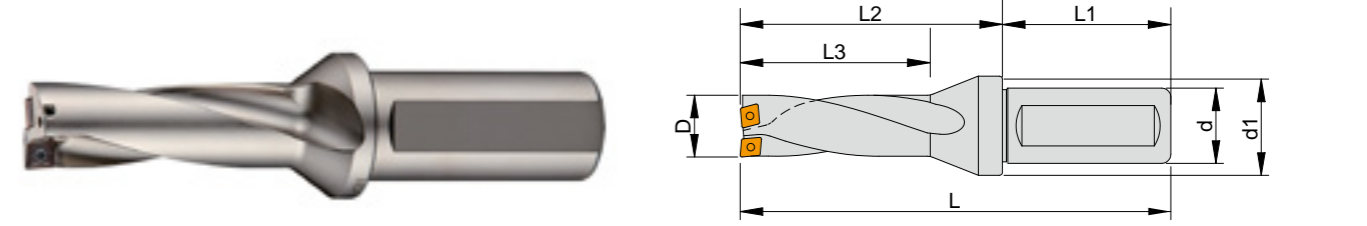

規格表 Specification

Unit: mm

型號 Model	D	d	d1	L	L3	L2	L1	刀片類型 Inserts	螺絲 Screw	板手 Wrench		
WDR5130-20T2-04	13	20	25	133	65	83	50	WDXT042004	TS1801	T06		
WDR5140-20T2-04	14			138	70	88						
WDR5150-20T2-04	15			144	75	94						
WDR5160-20T2-05	16			149	80	100		WDXT052504	TS2003	T06		
WDR5170-20T2-05	17			154	85	105						
WDR5180-20T2-05	18			159	90	110						
WDR5190-20T2-06	19			164	95	115						
WDR5200-20T2-06	20			169	100	120		WDXT063006	TS2203	T07		
WDR5210-25T2-06	21			25	33	185					105	125
WDR5220-25T2-06	22					190					110	130
WDR5230-25T2-07	23	195	115			140	WDXT073506	TS2511	T08			
WDR5240-25T2-07	24	200	120			145						
WDR5250-25T2-07	25	205	125			150						
WDR5260-32T2-07	26	217	130			155						
WDR5270-32T2-07	27	223	135			163	WDXT094008	TS3510	T15			
WDR5280-32T2-07	28	228	140			168						
WDR5290-32T2-09	29	233	145			173						
WDR5300-32T2-09	30	32	43			238	150	178	60	WDXT094008	TS3510	T15
WDR5310-32T2-09	31			243	155	183						
WDR5320-32T2-09	32			248	160	188						
WDR5330-32T2-09	33			253	165	193						
WDR5340-32T2-09	34			257	170	198						
WDR5350-32T2-09	35			263	175	203						
WDR5360-32T2-09	36			268	180	208						
WDR5440-40T5-12	44			40	53	325	220	255				

TDR 3D 快速鑽車刀
3D HIGH SPEED DRILL

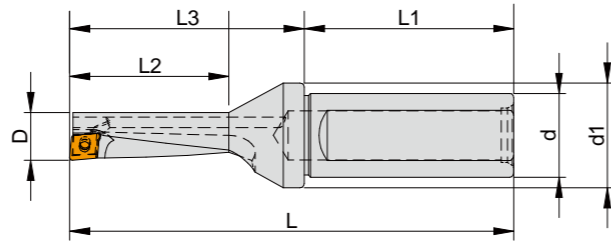
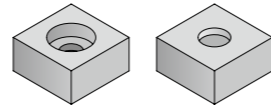

規格表 Specification

Unit: mm

型號 Model	D	d	d1	L	L3	L2	L1	刀片類型 Inserts	螺絲 Screw	板手 Wrench
TDR3080-20T1-04	8			95	45	24		WDXT042004	TS1801	T06
TDR3100-20T1-05	10	20	27	101	51	30	50	WDXT052504	TS2003	T06
TDR3120-20T1-06	12			107	57	36		WDXT063006	TS2205	T07
TDR3150-25T1-07	15	25	38	125	69	45	56	WDXT073506	TS2511	T08
TDR3190-25T1-09	19			137	81	57		WDXT094008	TS3510	T15
TDR3250-32T1-12	25	32	43	160	100	75	60	WDXT125012	TS5008	T20
TDR3300-32T1-15	30			175	115	90		WDXT156012	TS6004	T25

SEM 直角高速銑刀
ORTHOGONAL HIGH SPEED
MILLING CUTTER

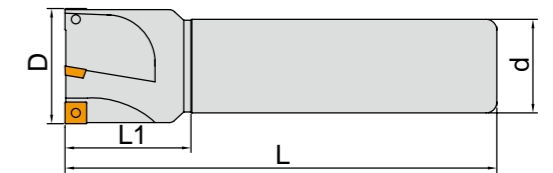
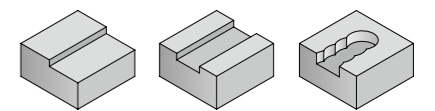

規格表 Specification

Unit: mm

型號 Model	D	L	L1	d	T	刀片類型 Inserts	螺絲 Screw	板手 Wrench
SEM 0512C12-2T	12	100	20	12	2	SPMG052004	TS2003	T06
SEM 0513C12-2T	13							
SEM 0514C12-2T	14							
SEM 0515C12-2T	15							
SEM 0616C16-2T	16	120	25	16	SPMG060204	TS2205	T06	
SEM 0617C16-2T	17							
SEM 0618C16-2T	18							
SEM 0619C16-2T	19							
SEM 0620C20-3T	20							
SEM 0621C20-3T	21		30	20				3
SEM 0622C20-3T	22							
SEM 0623C20-3T	23							
SEM 0624C20-3T	24							
SEM 0625C25-4T	25							
SEM 0626C25-4T	26	150	25	4	SPMG090408	TS3504	T15	
SEM 0627C25-4T	27							
SEM 0628C25-4T	28							
SEM 0629C25-4T	29							
SEM 0630C25-5T	30							
SEM 0631C25-5T	31		35	3				
SEM 0632C25-5T	32							
SEM 0633C25-5T	33							
SEM 0634C25-5T	34							
SEM 0635C25-5T	35							
SEM 0925C25-3T	25	40	32	4				
SEM 0926C25-3T	26							
SEM 0930C25-3T	30							
SEM 0930C32-4T	30							
SEM 0932C32-4T	32							
SEM 0933C32-4T	33							
SEM 0935C32-4T	35							
SEM 0940C32-4T	40							

SEC 殼型直角高速銑刀
SHELL TYPE ORTHOGONAL
HIGH SPEED MILLING CUTTER

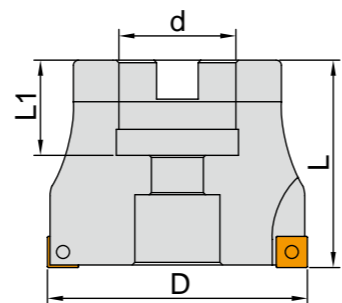
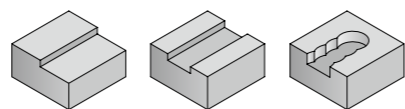

Unit: mm

規格表 Specification

型號 Model	D	L	L1	d	T	刀片類型 Inserts	螺絲 Screw	板手 Wrench
SEC 06R04006-16	40	40	18	16	6	SPMG062004	TS2205	T06
SEC 06R05007-22	50	45	20	22	7			
SEC 06R05007-25.4	0	45	20	25.4	7			
SEC 06R06309-22	63	45	20	22	9			
SEC 06R06309-25.4	3	45	20	25.4	9			
SEC 06R08011-227	80	50	23	27	11			
SEC 06R08011-25.4	0	50	23	25.4	11			
SEC 09R04004-16	40	40	18	16	4			
SEC 09R05005-22	50	45	20	22	5			
SEC 09R05005-25.4	0	45	20	25.4	5			
SEC 09R06306-22	63	45	20	22	6			
SEC 09R06306-25.4	3	45	20	25.4	6			
SEC 09R08007-27	80	50	23	27	7			
SEC 09R08007-25.4	0	50	23	25.4	7			
SEC 09R10009-32	100	50	23	32	9			
SEC 09R10009-31.75	100	50	23	31.75	9			

CDR 45°高速倒角刀
45° HIGH SPEED CHAMFERING
CUTTER

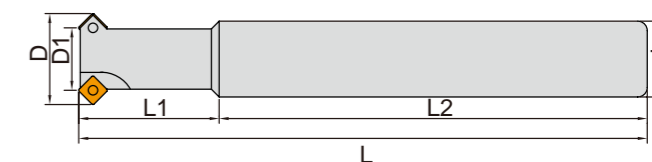
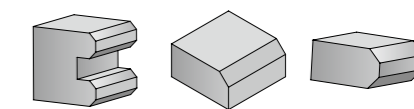

Unit: mm

規格表 Specification

型號 Model	D	D1	d	L1	L2	L	刀片類型 Inserts	螺絲 Screw	板手 Wrench
CDR 1106C10-1T	11	6	10	17	83	100	SPMG052004	TS2003	T06
CDR 1510C12-2T	15	10	12	20	100	120			
CDR 1711C16-3T	17	11	16	25	125	150			
CDR 1913C16-3T	19	13	16	30	120	150			
CDR 2418C20-4T	24	18	20	35	115	150			
CDR 2216C16-3T	22	16	16	30	80	120	SPMG060204	TS2205	T06
CDR 2717C20-3T	27	17	20	30	80	120	SPMG07T308	TS2511	T08
CDR 3019C20-2T	30	19	20	40	110	150	SPMG090408	TS3504	T15
CDR 4029C25-3T	40	29	25	40	110	150			
CDR 5039C25-4T	50	39	25	40	110	150			
CDR 2712C20-1T	27	12	20	40	110	150	SPMT120408	TS5002	T20
CDR 4025C25-2T	40	25	25	40	140	180			
CDR 4732C32-3T	47	32	32	40	160	200			
CDR 3525C20-2T	35	25	20	28	122	150	SPMW090304	TS4004	T15
CDR 4230C20-2T	42	30	20	30	120	150			

STM 高速T型刀
HIGH SPEED T-SLOT MILLING CUTTER

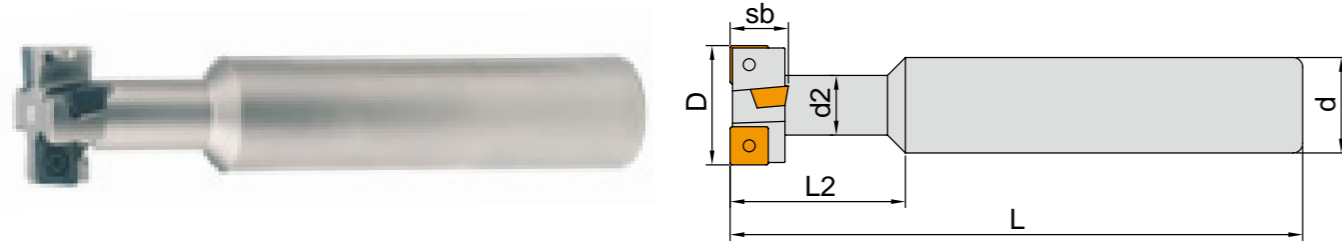
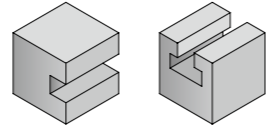

規格表 Specification

Unit: mm

型號 Model	D	sb	d2	L2	L	d	刀片類型 Inserts	螺絲 Screw	板手 Wrench
STM 1908-095L-4T	19	8	9.5	25	95	16	SPMG052004	TS2003	T06
STM 2109-100L-4T	21	9	11	27	100	16	SPMG060204	TS2205	T06
STM 2006-090L-4T	22	6.3	15	15	90	20	SPMG050204	TS2003	T06
STM 2511-110L-4T	25	11	12	31	110	20	SPMG07T308	TS2511	T08
STM 3207-110L-4T	32	7.8	19	9.5	110	20	SPMG050204	TS2003	T06
STM 3208-110L-4T	32	8	19	9.5	110	20	SPMG050204	TS2003	T06
STM 3210-100L-4T	32.6	10.5	23	30	100	25	SPMG07T308	TS2511	T08
STM 3214-110L-4T	32	14	17	39	110	25	SPMG090408	TS3504	T15
STM 4018-125L-4T	40	18	21	49	125	25	SPMG110408	TS4006	T15
STM 5022-130L-4T	50	22	27	61	130	32	SPMG140512	TS5009	T20
STM 5925-165-4T	58.65	25.12	32	55	165	32	SPMG140512	TS5009	T20
STM 6015-160L-4T	60	15	25	40	160	25	SPMG090408	TS3504	T15
STM 9510-160-4T	95	10	25	40	160	25	SPMG060204	TS2205	T06

Unit: mm

形狀 Shape	型號 Model	S	t	R	d	材質 Stocked		
						TT9030	TT8020	TT7400
	SPMG 050204 DG	5.00	2.38	0.4	2.25	•	•	•
	SPMG 060204 DG	6.00	2.38	0.4	2.61	•	•	•
	SPMG 07T308 DG	7.94	3.97	0.8	2.85	•	•	•
	SPMG 090408 DG	9.80	4.3	0.8	4.05	•	•	•
	SPMG 110408 DG	11.50	4.8	0.8	4.45	•	•	•
	SPMG 140512 DG	14.30	5.2	1.2	5.75	•	•	•

TDS T型銑刀
T-SLOT MILLING CUTTER

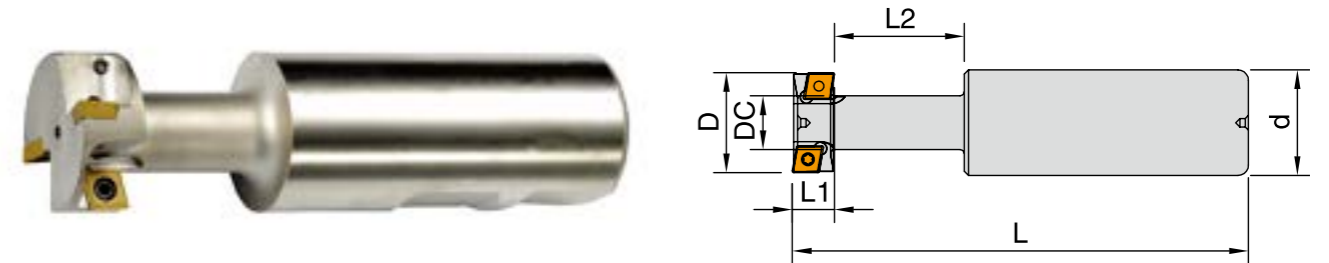
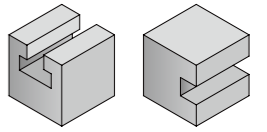

規格表 Specification

Unit: mm

型號 Model	D	Dc	d	L	L1	L2	T	刀片類型 Inserts	螺絲 Screw	板手 Wrench
TDS18-08-098L-2T	18	10	25	98	8	13	1x2	CCMT060204	TS2515	T08
TDS19-08-105L-2T	19	9	25	105	8	20	1x2	CCMT060204	TS2515	T08
TDS24-10-108L-2T	24	12.5	25	108	10	18	1x2	CCMT060204	TS2515	T08
TDS25-11-112L-2T	25	12.5	25	112	11	21	1x2	CCMT060204	TS2515	T08
TDS25-12-114L-2T	25	13.5	25	114	12	22	1x2	CCMT080304	TS2515	T10
TDS25-12-122L-4T	25	13	20	122	12	40	2x2	CCMT060204	TS2515	T08
TDS27-11-115L-4T	27	13	32	115	11	26	2x2	CCMT060204	TS2515	T08
TDS28-12-113L-4T	28	12.5	25	113	12	21	2x2	CCMT080304	TS3007	T10
TDS30-13-118L-4T	30	16	32	118	13	25	2x2	CCMT080304	TS3007	T10
TDS32-13-114L-4T	32	16	32	114	13	21	2x2	CCMT080304	TS3007	T10
TDS32-14-120L-4T	32	16	32	120	14	30	2x2	CCMT080304	TS3007	T10
TDS38-14-124L-4T	38	16	32	124	14	30	2x2	CCMT09T308	TS4004	T15
TDS40-18-130L-4T	40	20	32	130	18	32	2x2	CCMT09T308	TS4004	T15
TDS41-17-118L-4T	41	18	32	118	17	21	2x2	CCMT09T308	TS4004	T15
TDS42-21-124L-4T	42	20	32	124	21	23	2x2	CCMT120408	TS5002	T20
TDS48-20-153L-4T	48.1	27	32	153	20.1	30	2x2	CCMT120408	TS5002	T20
TDS50-10-120L-6T	50	22	32	120	10.3	30	2x2	CCMT060204	TS2515	T08
TDS50-15-120L-4T	50	22	32	120	15	28	2x2	CCMT09T304	TS4004	T20
TDS50-22-140L-4T	50	26	32	140	22	39	2x2	CCMT120408	TS5002	T20
TDS57-22-140L-4T	57	26	32	140	22	38	2x2	CCMT120408	TS5002	T20
TDS60-11-126L-6T	60	24	32	126	11	50	3x2	CCMT060208	TS2515	T08
TDS60-13-140L-6T	60	23	32	140	13	35	3x2	CCMT080304	TS3014	T08
TDS60-14-140L-6T	60	23	32	140	14.5	35	2x2	CCMT080304	TS4004	T15

RTM 圓頭T型銑刀
ROUND HEAD T-SLOT MILLING CUTTER

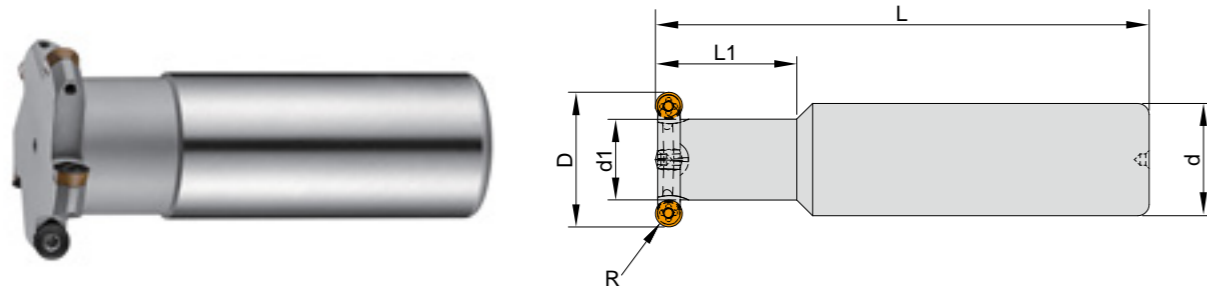
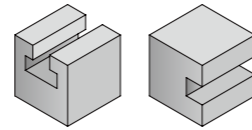

規格表 Specification

型號 Model	D	d	d1	L1	L	R	T	刀片類型 Inserts	螺絲 Screw	板手 Wrench
RTM0526-21-C25-105L	26	25	18	21	105	2.5	5	RDMT0501MO	TS2001	T06
RTM0533-25-C32-110L	33	32	23	25	110	2.5	6	RDMT0501MO	TS2001	T06
RTM0630-35-C25-110L	30	25	18	35	110	3	4	RDMW0620MO	TS2205	T06
RTM0650-30-C32-110L	50	32	32	30	110	3	6	RDMT0620MO	TS2504	T08
RTM0740-26-C32-110L	39.3	32	26	26	110	3.5	5	RDMX0702MO	TS2515	T08
RTM0850-28-C32-110L	50	32	30	28	110	4	5	RDMX0803MO	TS3007	T10
RTM1050-35-C32-150L	50	32	28	35	150	5	4	RPMW10T3MO	TS3503	T15
RTM1250-40-C32-150L	50	32	25	40	150	6	3	RPMW1204MO	TS4006	T15

Unit: mm

SRE 高速粗銑刀
HIGH SPEED ROUGH MILLING CUTTER

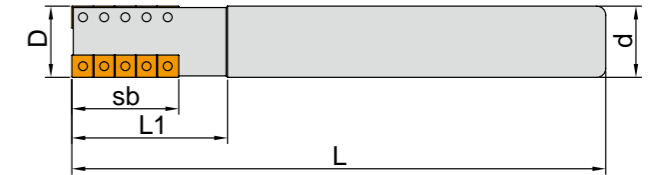
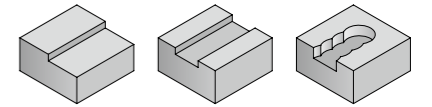

規格表 Specification

型號 Model	D	sb	L	d	L1	T	刀片 Inserts	刀片類型 Inserts	螺絲 Screw	板手 Wrench
SRE.W.016.Z02.020.05	16	20	120	16	30	2	10	SPMG 050204	TS2003	T06
SRE.W.020.Z02.030.06	20	30	110	20	40	2	12	SPMG 060204	TS2205	T06
SRE.W.025.Z02.040.07	25	40	130	25	55	2	12	SPMG 07T308	TS2511	T08
SRE.W.032.Z02.050.09	32	50	150	32	65	2	12	SPMG 090408	TS3504	T15
SRE.W.040.Z03.070.09	40	70	180	32	90	3	24	SPMG 090408		
SRE.W.040.Z03.088.09	40	88	200	42	110	3	33	SPMG 090408		
SRE.W.050.Z03.100.1204	50	100	224	50.8	124	3	30	SPMT 120408	TS5004	T20
SRE.W.050.Z03.156.1204	50	156	284	50.8	184	3	45	SPMT 120408		
SRE.W.050.Z03.100.1206	50	100	224	50.8	124	3	30	SPMT 120606	TS5006	T20
SRE.W.050.Z03.156.1206	50	156	284	50.8	184	3	45	SPMT 120606		

Unit: mm

DFW 高速側銑三面刀
HIGH SPEED SIDE MILLING CUTTER

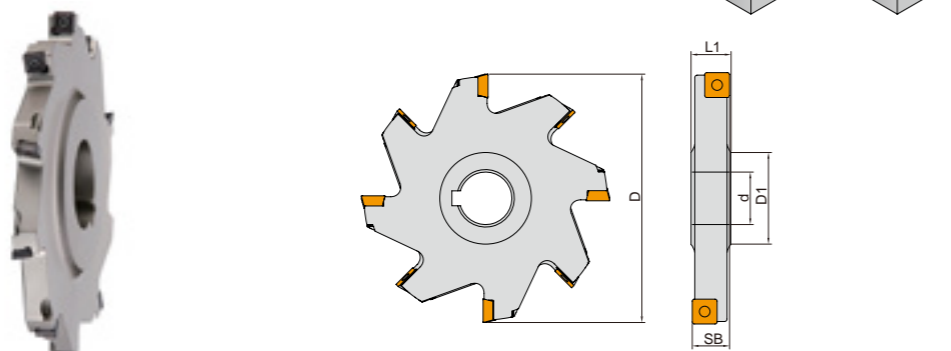

規格表 Specification

Unit: mm

型號 Model	D	SB	d	L1	D1	T	刀片類型 Inserts	螺絲 Screw	板手 Wrench		
DFW.B.080.Z08.06-25.4	80	6	25.4	8	44	2 x 4	SPMG050204	TS2003	T06		
DFW.B.080.Z08.07-25.4		7									
DFW.B.080.Z08.08-25.4		8									
DFW.B.080.Z08.09-25.4		9									
DFW.B.080.Z08.10-25.4		10		10							
DFW.B.080.Z08.11-25.4		11									
DFW.B.080.Z08.12-25.4		12									
DFW.B.100.Z10.06-25.4		6					100	8	44	2 x 5	SPMG050204
DFW.B.100.Z10.07-25.4	7										
DFW.B.100.Z10.08-25.4	8										
DFW.B.100.Z10.09-25.4	9										
DFW.B.100.Z10.10-25.4	10	10									
DFW.B.100.Z10.11-25.4	11										
DFW.B.100.Z10.12-25.4	12										
DFW.B.100.Z10.14-25.4	14										
DFW.B.100.Z10.16-25.4	16	16									
DFW.B.125.Z12.06-31.75	6		125	8	54	2 x 6		SPMG050204	TS2003	T06	
DFW.B.125.Z12.07-31.75	7										
DFW.B.125.Z12.08-31.75	8										
DFW.B.125.Z12.10-31.75	10										10
DFW.B.125.Z12.11-31.75	11										
DFW.B.125.Z12.12-31.75	12										
DFW.B.125.Z12.14-31.75	14										
DFW.B.125.Z12.16-31.75	16	16									
DFW.B.125.Z10.18-31.75	18			31.75	20	54	2 x 5	SPMG110408	TS4006	T15	
DFW.B.125.Z10.20-31.75	20										
DFW.B.125.Z10.25-31.75	25										
DFW.B.160.Z16.11-31.75	11	160									12
DFW.B.160.Z16.12-31.75	12										
DFW.B.160.Z16.14-31.75	14										
DFW.B.160.Z16.16-31.75	16				16						
DFW.B.160.Z16.18-31.75	18						40	20	80	2 x 6	SPMG110408
DFW.B.160.Z12.18-31.75	18										
DFW.B.160.Z12.20-31.75	20										
DFW.B.160.Z12.25-31.75	25										
DFW.B.200.Z18.14-40	14	200	16	80	2 x 9	SPMG090408		TS3504		T15	
DFW.B.200.Z18.16-40	16										
DFW.B.200.Z14.18-40	18										20
DFW.B.200.Z14.20-40	20										
DFW.B.200.Z14.25-40	25		25								
DFW.B.200.Z14.25-40	25										

DFW 高速側銑三面刀
HIGH SPEED SIDE MILLING CUTTER

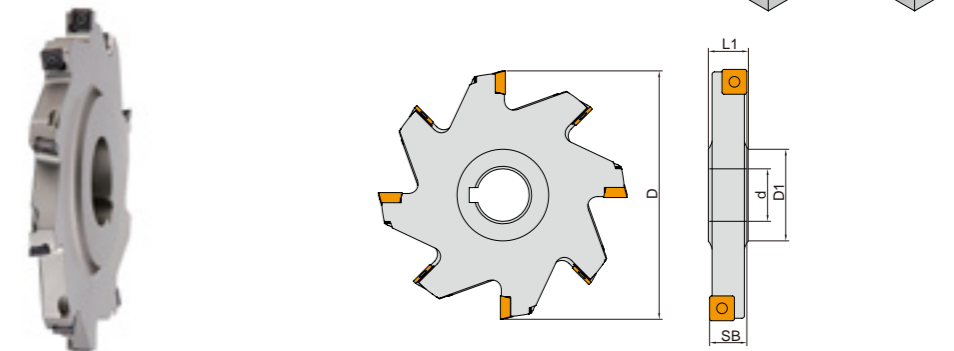

規格表 Specification

Unit: mm

型號 Model	D	SB	d	L1	D1	T	刀片類型 Inserts	螺絲 Screw	板手 Wrench		
DFW.B.080.Z08.06-22	80	6	22	8	44	2 x 4	SPMG050204	TS2003	T06		
DFW.B.080.Z08.07-22		7									
DFW.B.080.Z08.08-22		8									
DFW.B.080.Z08.09-22		9									
DFW.B.080.Z08.10-22		10		10							
DFW.B.080.Z08.11-22		11									
DFW.B.080.Z08.12-22		12									
DFW.B.100.Z10.06-27		6					100	27	44	2 x 5	SPMG050204
DFW.B.100.Z10.07-27	7										
DFW.B.100.Z10.08-25.4	8	25.4									
DFW.B.100.Z10.09-27	9										
DFW.B.100.Z10.10-27	10		10								
DFW.B.100.Z10.11-27	11										
DFW.B.100.Z10.12-27	12										
DFW.B.100.Z10.14-27	14										
DFW.B.100.Z10.16-27	16	16									
DFW.B.125.Z12.06-32	6		125	32	54	2 x 6		SPMG050204	TS2003	T06	
DFW.B.125.Z12.07-32	7										
DFW.B.125.Z12.08-32	8										
DFW.B.125.Z12.10-32	10										10
DFW.B.125.Z12.11-32	11										
DFW.B.125.Z12.12-32	12										
DFW.B.125.Z12.14-32	14										
DFW.B.125.Z12.16-32	16	16									
DFW.B.125.Z10.18-32	18			31.75	20	54	2 x 5	SPMG110408	TS4006	T15	
DFW.B.125.Z10.20-32	20										
DFW.B.125.Z10.25-32	25										
DFW.B.160.Z16.11-40	11	160									12
DFW.B.160.Z16.12-40	12										
DFW.B.160.Z16.14-40	14										
DFW.B.160.Z16.16-40	16				16						
DFW.B.160.Z12.18-40	18						40	20	80	2 x 6	SPMG110408
DFW.B.160.Z12.20-40	20										
DFW.B.160.Z12.25-40	25										
DFW.B.200.Z18.14-40	14		200	16	80	2 x 9					
DFW.B.200.Z18.16-40	16										
DFW.B.200.Z14.18-40	18	20									
DFW.B.200.Z14.20-40	20										
DFW.B.200.Z14.25-40	25			25							
DFW.B.200.Z14.25-40	25										

DFC 殼型高速側銑三面刀
SHELL TYPE HIGH SPEED SIDE MILLING CUTTER

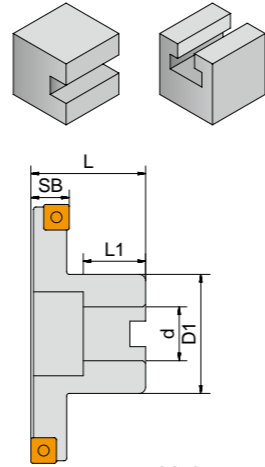
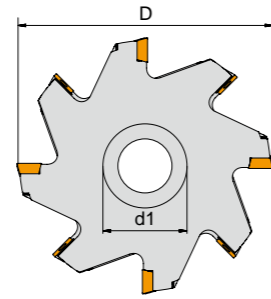
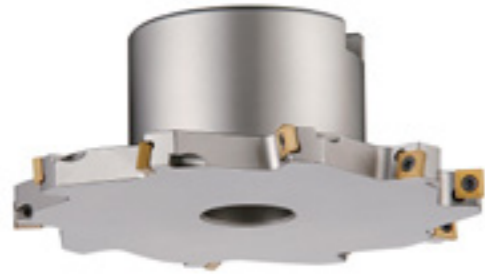

規格表 Specification

型號 Model	D	SB	L	L1	D1	d1	d	T	刀片類型 Inserts	螺絲 Screw	板手 Wrench
DFC.B.080.Z08.06-22	80	6	40	22	44	32	22	2x4	SPMG050204	TS2003	T06
DFC.B.080.Z08.07-22		7									
DFC.B.080.Z08.08-22		8									
DFC.B.080.Z08.09-22		9							SPMG060204	TS2205	T06
DFC.B.080.Z08.10-22		10									
DFC.B.080.Z08.11-22		11									
DFC.B.080.Z08.12-22		12									
DFC.B.100.Z10.06-27	100	6	40	22	50	32	27	SPMG050204	TS2003	T06	
DFC.B.100.Z10.07-27		7									
DFC.B.100.Z10.08-27		8									
DFC.B.100.Z10.09-27		9						SPMG060204	TS2205	T06	
DFC.B.100.Z10.10-27		10									
DFC.B.100.Z10.11-27		11									
DFC.B.100.Z10.12-27		12									
DFC.B.100.Z10.14-27	14	SPMG07T308	TS2511	T08							
DFC.B.100.Z10.16-27	16										
DFC.B.125.Z12.06-32	125				6	45	25	70	46	32	SPMG050204
DFC.B.125.Z12.07-32		7									
DFC.B.125.Z12.08-32		8									
DFC.B.125.Z12.10-32		10	SPMG060204	TS2205	T06						
DFC.B.125.Z12.11-32		11									
DFC.B.125.Z12.12-32		12									
DFC.B.125.Z12.14-32		14									
DFC.B.125.Z12.16-32	16	SPMG07T308	TS2511	T08							
DFC.B.125.Z10.18-32	18										
DFC.B.125.Z10.20-32	20										
DFC.B.125.Z10.25-32	25	SPMG090408	TS3504	T15							
DFC.B.160.Z16.11-40	160				11	50	28	80	52	40	SPMG110408
DFC.B.160.Z16.12-40		12									
DFC.B.160.Z16.14-40		14									
DFC.B.160.Z16.16-40		16	SPMG090408	TS3504	T15						
DFC.B.160.Z12.18-40		18									
DFC.B.160.Z12.20-40		20									
DFC.B.160.Z12.25-40		25									
DFC.B.200.Z18.14-40	200	14	50	28	90	52	40	SPMG07T308	TS2511	T08	
DFC.B.200.Z18.16-40		16									
DFC.B.200.Z14.18-40		18									SPMG110408
DFC.B.200.Z14.20-40		20									
DFC.B.200.Z14.25-40		25						SPMG140512	TS5009	T20	
DFC.B.200.Z18.14-40	14	SPMG090408	TS3504	T15							
DFC.B.200.Z18.16-40	16										
DFC.B.200.Z14.18-40	18	SPMG110408	TS4006	T15							
DFC.B.200.Z14.20-40	20										
DFC.B.200.Z14.25-40	25				SPMG140512	TS5009	T20				

Unit: mm

SRB 高速粗搪刀
HIGH SPEED ROUGH BORING CUTTER

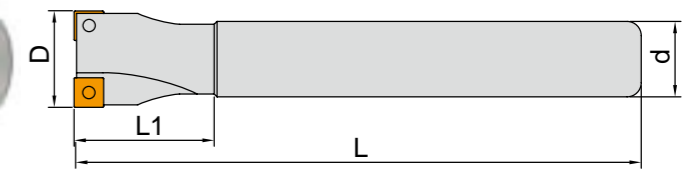
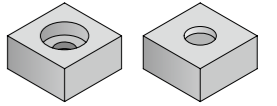

規格表 Specification

型號 Model	D	d	L1	L	T	刀片類型 Inserts	螺絲 Screw	板手 Wrench
SRB 1210R-2T	11.8	10	20	100	2	SPMG050204	TS2003	T06
SRB 1312R-2T	12.8	12	20	100				
SRB 1412R-2T	13.8	12	25	100				
SRB 1512R-2T	14.8	12	25	100				
SRB 1612R-2T	15.8	12	30	100				
SRB 1816R-2T	17.7	16	30	130				
SRB 2016R-2T	19.7	16	30	130				
SRB 2216R-2T	21.7	16	30	130				
SRB 2420R-2T	23.7	20	30	150				
SRB 2520R-2T	24.7	20	30	150				
SRB 2620R-2T	25.7	20	30	150				
SRB 2720R-2T	26.7	20	30	150				
SRB 2820R-2T	27.7	20	30	150				
SRB 3025R-2T	29.7	25	40	200				
SRB 3225R-2T	31.7	25	40	200				
SRB 3525R-2T	34.7	25	40	200				
SRB 3625R-2T	35.7	25	40	200				
SRB 4025R-2T	39.7	25	40	200				
SRB 4232R-2T	41.7	32	45	200				
SRB 4532R-2T	44.7	32	45	200				
SRB 4832R-2T	47.7	32	45	200				
SRB 5032R-2T	49.7	32	45	200				
						SPMG090408	TS3504	T15

Unit: mm

DTB 定值粗搪刀
ROUGH BORING CUTTER

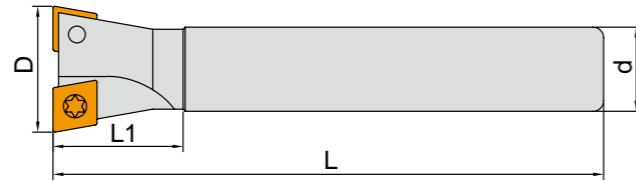
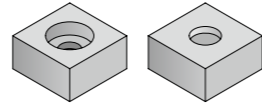

規格表 Specification

Unit: mm

型號 Model	D	d	L1	L	刀片類型 Inserts	螺絲 Screw	板手 Wrench
DTB 1412R-1T	13.8	12	25	100	CCMT060204	TS2515	T06
DTB 1612R-2T	15.8	12	30	100			
DTB 1816R-2T	17.7	16	30	120			
DTB 1916R-2T	18.7	16	30	120			
DTB 2016R-2T	19.7	16	30	120			
DTB 2216R-2T	21.7	16	30	120			
DTB 2420R-2T	23.7	20	30	130			
DTB 2520R-2T	24.7	20	30	130			
DTB 2620R-2T	25.7	20	30	130			
DTB 2720R-2T	26.7	20	30	130			
DTB 2820R-2T	27.7	20	30	130	CCMT09T304	TS4004	T15
DTB 3025R-2T	29.7	25	40	160			
DTB 3225R-2T	31.7	25	40	160			
DTB 3525R-2T	34.7	25	40	160			
DTB 3625R-2T	35.7	25	40	160			
DTB 4025R-2T	39.7	25	40	160			
DTB 4232R-2T	41.7	32	45	200			
DTB 4532R-2T	44.7	32	45	200			
DTB 4832R-2T	47.7	32	45	200			
DTB 5032R-2T	49.7	32	45	200			
DTB 5232R-2T	51.7	32	45	200			
DTB 5532R-2T	54.7	32	45	200			

TE90AX 高速直角銑刀
ORTHOGONAL HIGH SPEED MILLING CUTTER

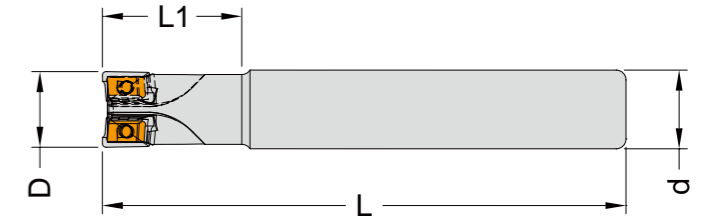
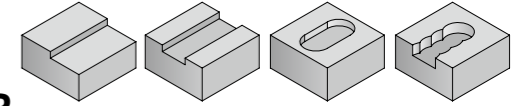

規格表 Specification

Unit: mm

型號 Model	D	d	L1	L	T	刀片類型 Inserts	螺絲 Screw	板手 Wrench	
TE90AX210-06	10	10	18	80	2	AXMT060208...	TS1801	T06	
TE90AX211-06	11	12							
TE90AX312-06	12								
TE90AX313-06	13	16	90	3					
TE90AX316-06	16								
TE90AX417-06	17								
TE90AX418-06	18								
TE90AX420-06	20	20	105	4					
TE90AX625-06	25			20	120				6
TE90AX216-09	16	16	30						2
TE90AX217-09	17								
TE90AX320-09	20								
TE90AX321-09	21	20	150	3	APKT090308...				
TE90AX425-09	25			4					
TE90AX426-09	26	25	35	2	APKT1204...	TS3504	T15		
TE90AX220-12	20								
TE90AX221-12	21	25	100	3					
TE90AX325-12	25								
TE90AX326-12	26	32	35	4					
TE90AX432-12	32								
TE90AX433-12	33								

TE90AX

鎖牙式直角高速銑刀
 THREADED ORTHOGONAL
 HIGH SPEED MILLING CUTTER

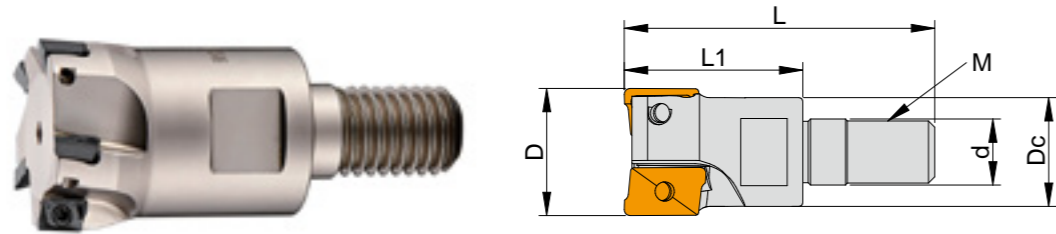
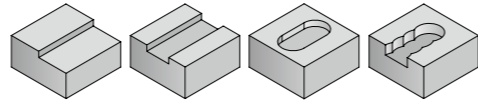

規格表 Specification

Unit: mm

型號 Model	D	DC	d	L	L1	T	M	刀片類型 Inserts	螺絲 Screw	扳手 Wrench
TE90AX210-M05	10	33	5.5	9	16	2	M5	AXMT060208...	TS1801	T06
TE90AX211-M05	11									
TE90AX212-M08	12	11	8.5	40	23		M8	APKT090308...	TS2515	T08
TE90AX313-M06	13	11	6.5	32.5	18	3	M6	AXMT060208...	TS1801	T06
TE90AX316-M08	16	14	8.5	14	23		M8	APKT090308...	TS2515	T08
TE90AX317-M08	17									
TE90AX321-M10	21	18	10.5	49	30		M10			
TE90AX326-M12	26	23	12.5	57	35	M12				
TE90AX421-M10	21	20	10.5	49	30	4	M10	AXMT060208...	TS1801	T06
TE90AX526-M12	26	22	12.5	57	35	5	M12			

TE903P

直角高速銑刀
 ORTHOGONAL HIGH
 SPEED MILLING CUTTER

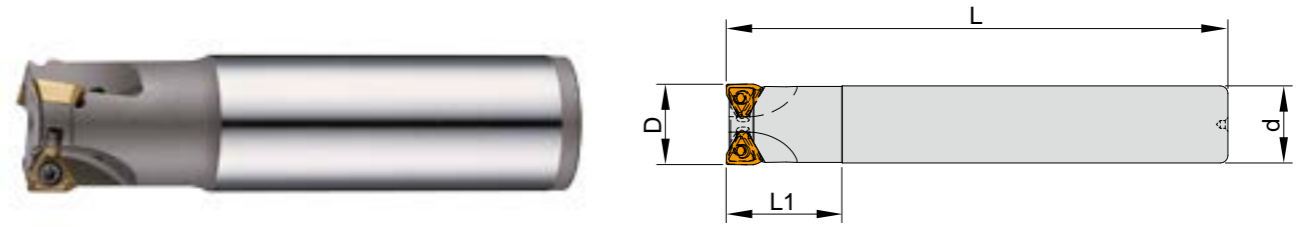
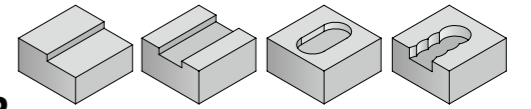

規格表 Specification

Unit: mm

型號 Model	D	d	L1	L	T	刀片類型 Inserts	螺絲 Screw	扳手 Wrench
TE903P-220-10-C20-130L	20	20	50	130	2	3PKT100404	TS2517	T09
TE903P-221-10-C20-130L	21	20	30	130	2			
TE903P-325-10-C25-150L	25	25	55	150	3			
TE903P-326-10-C25-150L	26	25	35	150	3			
TE903P-333-15-C32-200L	33	32	45	200	3	3PKT150508	TS4014	T15
TE903P-440-15-C32-200L	40	32	45	200	4			
TE903P-217-10-C16-160L	17	16	30	160	2	3PHT100408R-M CT7000	TS2517	TK09
TE903P-220-10-C19-200L	20	19	30	200	2			
TE903P-221-10-C20-200L	21	20	30	200	2			
TE903P-225-10-C24-250L	25	24	30	250	2			
TE903P-226-10-C25-250L	26	25	30	250	2			
TE903P-230-10-C29-250L	30	29	30	250	2			
TE903P-232-10-C30-250L	32	30	30	250	2			
TE903P-235-10-C32-330L	35	32	30	330	2			

TEBL 高速進給銑刀
HIGH SPEED FEED
MILLING CUTTER

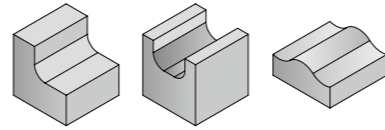

規格表 Specification							Unit: mm		
型號 Model	D	d	L1	L	T	刀片 Insert	螺絲 Screw	板手 Wrench	
TEBL215-16-L130-TW	15	16	130	25	2	BLMP0603...	TS3004	T08	
TEBL215-16-L75-TW	15	16	75	25	2				
TEBL216-16-L130-TW	16	16	130	25	2				
TEBL217-16-L130-TW	17	16	130	25	2				
TEBL218-20-L130-TW	18	20	130	25	2				
TEBL218-20-L75-TW	18	20	75	25	2				
TEBL320-20-L150-TW	20	20	150	40	3				
TEBL321-20-L150-TW	21	20	150	40	3				
TEBL425-25-L150-TW	25	25	150	40	4				
TEBL426-25-L150-TW	26	25	150	30	4				
TEBL432-32-L200-TW	32	32	200	45	4				

TEBL 殼型高速進給銑刀
SHELL TYPE HIGH SPEED
FEED MILLING CUTTER

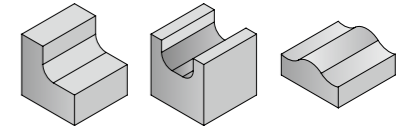

規格表 Specification							Unit: mm		
型號 Model	D	d	Dc	L1	L	T	刀片 Insert	螺絲 Screw	板手 Wrench
TEBL540-22-L50-TW	40	22	38	50	21	5	BLMP0603...	TS3004	T08
TEBL640-22-L50-TW	40	22	38	50	21	6			
TEBL750-22-L50-TW	75	22	45	50	22	7			
TEBL763-22-L50-TW	63	22	58	50	22	7			

TEBL 鎖牙式高速進給銑刀
THREADED HIGH SPEED
FEED MILLING CUTTER

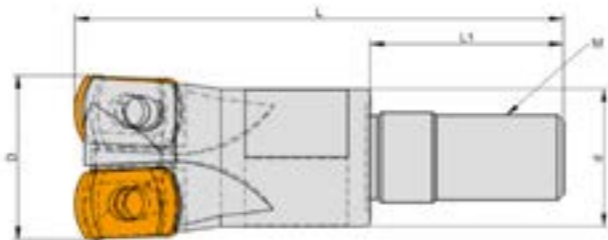
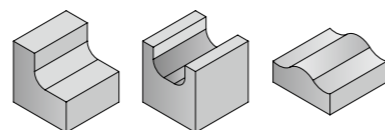

規格表 Specification							Unit: mm		
型號 Model	D	d	L	L1	M	T	刀片 Insert	螺絲 Screw	板手 Wrench
TEBL216-M08	16	13	43	17	M08	2	BLMP0603...	TS3004	T08
TEBL321-M10	21	18	49	19	M10	3			
TEBL325-M12	25	23	57	22	M12	3			
TEBL425-M12	25	23	57	22	M12	4			

ASR 高速進給銑刀
HIGH SPEED FEED
MILLING CUTTER

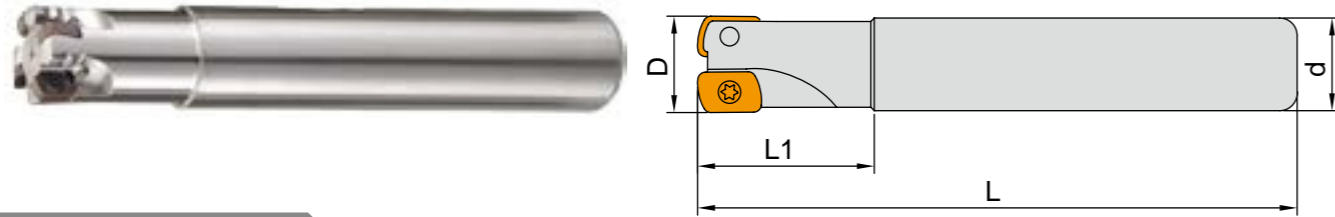
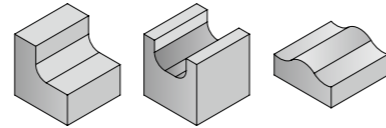

規格表 Specification

型號 Model	D	L	L1	d	T	刀片類型 Inserts	螺絲 Screw	板手 Wrench
ASR2016S-2	16	130	35	16	2	EPNW0603TN-8 EPMT0603TN-8 EPMT0603EN-8LF	TS2515	T08
ASR2017S-2	17		35					
ASR2020S-3	20	150	40	20	3			
ASR2021S-3	21		40					
ASR2025S-4	25		50	25	4			
ASR2026S-4	26		40					
ASR2030S-4	30	32	45	32	5			
ASR2032S-5	32							
ASR2035S-5	35							
ASR2040S-6	40	170	45	32	6			
ASR2016L-2	16	180	50	16	2			
ASR2017L-2	17		35					
ASR2020L-3	20	200	80	20	3			
ASR2021L-3	21		35					
ASR2025L-4	25		100	25	4			
ASR2026L-4	26		35					
ASR2030L-4	30	100	100	32	5			
ASR2032L-5	32							
ASR2040L-6	40					220	45	32

Unit: mm

ASR 鎖牙式高速進給銑刀
THREADED HIGH SPEED FEED
MILLING CUTTER

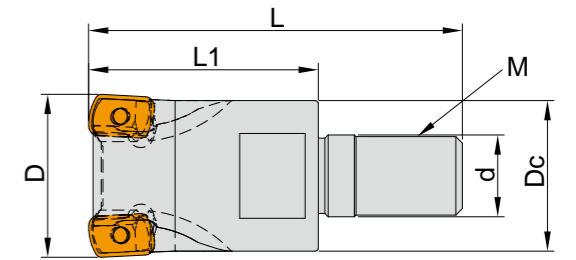
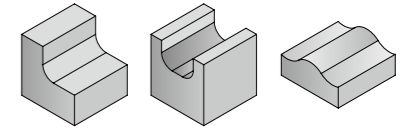

規格表 Specification

型號 Model	D	Dc	d	L	L1	刀片類型 Inserts	螺絲 Screw	板手 Wrench
ASR2016-M08-2	16	14	8.5	43	26	EPNW0603TN-8 EPMT0603TN-8	TS2515	T08
ASR2017-M08-2	17	14	8.5	43	26			
ASR2020-M10-3	20	18	10.5	50	32			
ASR2021-M10-3	21	18	10.5	50	32			
ASR2025-M12-4	25	23	12.5	60	38			
ASR2026-M12-4	26	23	12.5	60	38			
ASR2032-M16-5	32	29	17	63	41			
ASR2035-M16-5	35	29	17	63	41			

Unit: mm

ASR 殼型高速進給銑刀
SHELL TYPE HIGH SPEED FEED
MILLING CUTTER

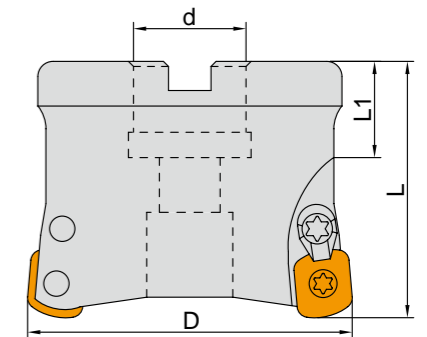
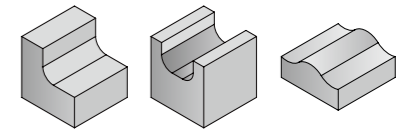

規格表 Specification

型號 Model	D	Dc	d	L	L1	T	刀片類型 Inserts	螺絲 Screw	板手 Wrench
ASR20050-22-6	50	47	22	50	22	6	EPNW0603TN-8 EPMT0603TN-8	TS2515	T08
ASR20063-22-7	63	55	22	50	22	7			
ASR20063-25.4-7	63	55	25.4	50	21	7			
ASR20066-22-8	66	60	22	50	22	8			
ASR20066-25.4-8	66	60	25.4	50	21	8			

Unit: mm

ASRFS 高速銑刀
HIGH SPEED
MILLING CUTTER

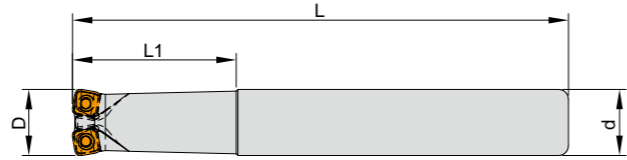
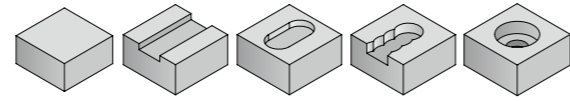

規格表 Specification

Unit: mm

型號 Model	D	d	L1	L	T	刀片類型 Inserts	螺絲 Screw	板手 Wrench
ASRFS3020R-2T-150	20	20	50	150	2	SPMT07T0TR	TS3011	T08
ASRFS3021R-2T-150	21		30					
ASRFS3025R-3T-150	25	25	60	150	3			
ASRFS3025R-3T-200			100	200				
ASRFS3026R-3T-150			35	150				
ASRFS3026R-3T-200	26	35	200					
ASRFS3032R-4T-150	32	32	70	150	4			
ASRFS3032R-4T-200			100	200				
ASRFS3035R-4T-150			40	150				
ASRFS3035R-4T-200	35	40	200					

ASRFB 殼型高速銑刀
SHELL TYPE HIGH SPEED
MILLING CUTTER

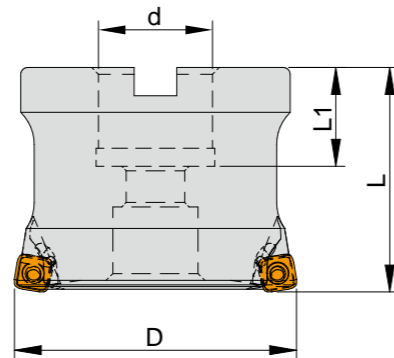
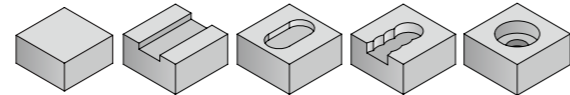

規格表 Specification

Unit: mm

型號 Model	D	d	L1	L	T	刀片類型 Inserts	螺絲 Screw	板手 Wrench
ASRFB3050R-7T-22	50	22	20	50	7	SPMT07T2TR	TS3011	T08
ASRFB3063R-8T-25.4	63	25.4	20		8			
ASRFB3066R-7T-22	66	22	20	50	7			
ASRFB3080R-9T-27	80	27	26	50	9			

TDN 高速進給銑刀
HIGH SPEED FEED
MILLING CUTTER

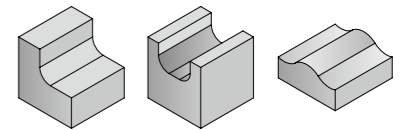

規格表 Specification

Unit: mm

型號 Model	D	d	L	L1	T	刀片 Insert	螺絲 Screw	板手 Wrench
TDN2016-150-2	16	16	150	25	2	ENMU0603ER	TS2515	T08
TDN2017-150-2	17	16	150	25	2			
TDN2020-150-3	20	20	150	25	3			
TDN2021-150-3	21	20	150	30	3			
TDN2025-150-4	25	25	150	30	4			
TDN2026-150-4	26	25	150	35	4			
TDN2030-150-4	30	32	150	35	4			
TDN2032-150-5	32	32	150	40	5			
TDN2035-150-5	35	32	150	40	5			
TDN2040-170-6	40	32	170	45	6			

TDN 鎖牙式高速進給銑刀
TREADED HIGH SPEED
FEED MILLING CUTTER

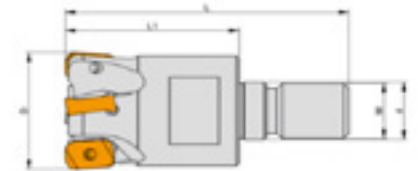
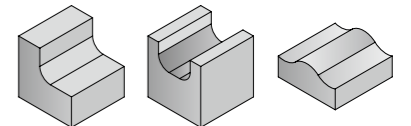

規格表 Specification

Unit: mm

型號 Model	D	d	L	L1	M	T	刀片 Insert	螺絲 Screw	板手 Wrench
TDN2016-M08-2	16	8.5	43	26	M08	2	ENMU0603ER	TS2515	T08
TDN2017-M08-2	17	8.5	43	26	M08	2			
TDN2020-M10-3	20	10.5	50	32	M10	3			
TDN2021-M10-3	21	10.5	50	32	M10	3			
TDN2025-M12-4	25	12.5	60	38	M12	4			
TDN2026-M12-4	26	12.5	60	38	M12	4			
TDN2032-M16-5	32	17	63	41	M16	5			
TDN2035-M16-5	35	17	63	41	M16	5			

UEX 鎖牙式直角銑刀
THREADED ORTHOGONAL MILLING CUTTER

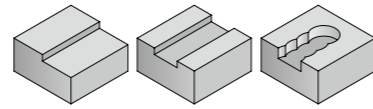
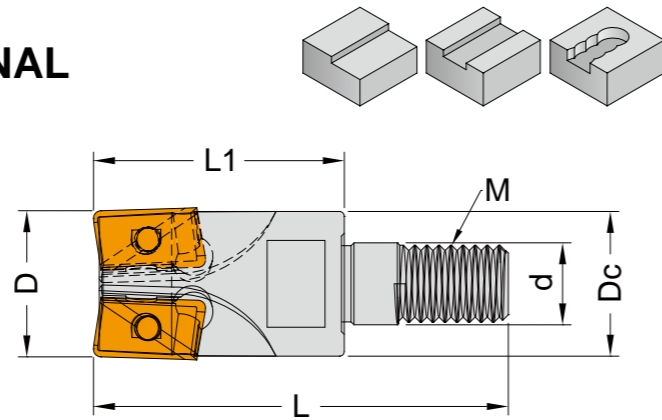

規格表 Specification

Unit: mm

型號 Model	D	Dc	L1	L	d	M	刀片類型 Inserts	螺絲 Screw	板手 Wrench
UEX161-M08	16	15	25	42	8.5	M8	APNT1202... APET1202...	TS3502	T15
UEX171-M08	17	15	25	42	8.5	M8			
UEX202-M10	20	18	30	42	10.5	M10			
UEX212-M10	21	18	30	42	10.5	M10			
UEX252-M12	25	23	35	57	12.5	M12	TS4002		
UEX262-M12	26	23	35	57	12.5	M12			
UEX302-M12	30	23	35	57	12.5	M12	ADNT1603... APET1603...	TS4004	
UEX323-M16	32	30	37	60	17	M16			
UEX333-M16	33	30	37	60	17	M16			
UEX353-M16	35	30	37	60	17	M16			

AHU 直角高速銑刀
ORTHOGONAL HIGH SPEED MILLING CUTTER

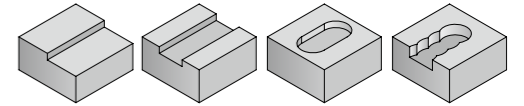
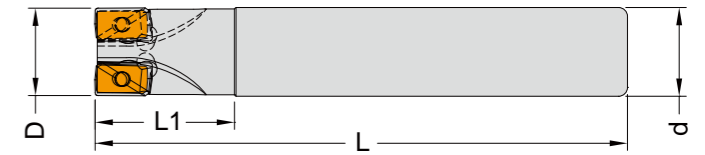

規格表 Specification

Unit: mm

型號 Model	D	d	L1	L	T	刀片類型 Inserts	螺絲 Screw	板手 Wrench
AHU1010-100-1T	10	10	20	100	1	JDMT1003... JDET1003...	TS2504	T08
AHU1012-100-1T	12	12	25	100	1			
AHU1016-100-2T	16	16	30	100	2			
AHU1016-150-2T	16	16	50	150	2			
AHU1017-150-2T	17	16	30	150	2			
AHU1018-160-2T	18	16	30	160	2			
AHU1020-110-3T	20	20	30	110	3			
AHU1020-160-2T	20	20	60	160	2			
AHU1020-160-3T	20	20	60	160	3			
AHU1021-150-3T	21	20	30	150	3			
AHU1022-160-3T	22	20	30	180	2			
AHU1025-120-4T	25	25	35	120	4			
AHU1025-180-2T	25	25	75	180	2			
AHU1026-150-4T	26	25	35	150	4			
AHU1032-130-5T	32	32	45	130	5			
AHU1032-200-4T	32	32	90	200	4			
AHU1525-125-2T	25	25	40	125	2	JDMT1505... JDET1505...	TS4002	T15
AHU1525-180-2T	25	25	75	180	2			
AHU1532-140-3T	32	32	45	140	3			
AHU1532-200-3T	32	32	90	200	3			

AJU 鑽銑刀
DRILLING & MILLING CUTTER

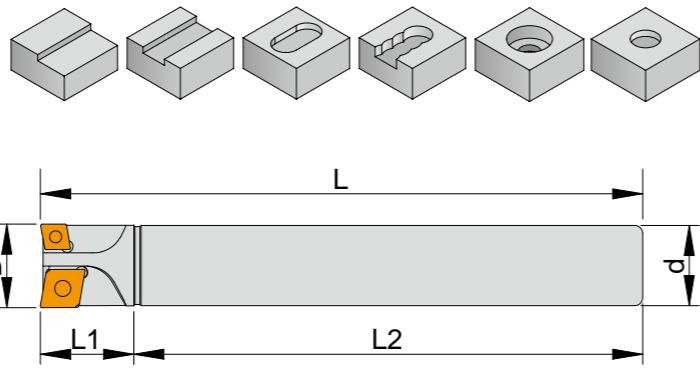

規格表 Specification

型號 Model	D	d	L1	L2	L	T	刀片類型 Inserts	螺絲 Screw	扳手 Wrench
AJU1010-130	10	10	30	100	130	1	CCMT060204Z	TS2505	T08
AJU1212-120	12	12	30	120	120		CPMT080204Z	TS2505	T08
AJU1212-150	12	12	40	110	150				
AJU1616-120	16	16	30	90	120	2	CPMT080204Z CCMT060204	TS2505	T08
AJU1616-150	16	16	40	110	150				
AJU1616-175	16	16	40	135	175				
AJU1716-150	17	16	30	90	150				
AJU1716-175	17	16	30	90	175				
AJU1716-200	17	16	30	90	200				
AJU2020-120	20	20	30	90	120				
AJU2020-185	20	20	50	135	185				
AJU2120-150	21	20	30	120	150				
AJU2120-200	21	20	30	170	200				
AJU2525-150	25	25	40	110	150	CPMT120308Z CPMT090308	TS4023	T15	
AJU2525-220	25	25	70	150	220				
AJU2625-150	26	25	30	120	150	CPMT160408Z CPMT120408	TS5007	T20	
AJU2625-200	26	25	30	170	200				
AJU3232-150	32	32	30	120	150				
AJU3232-250	32	32	80	170	250				
AJU3232-300	32	32	80	22	300				
AJU3232-350	32	32	80	270	350				
AJU4032-170	40	32	30	120	170	CPMT160408Z CPMT120408	TS5007 TS6001	T20 T25	
AJU4032-250	40	32	80	170	250				

Unit: mm

AJU 鎖牙式鑽銑刀
THREADED DRILLING & MILLING CUTTER

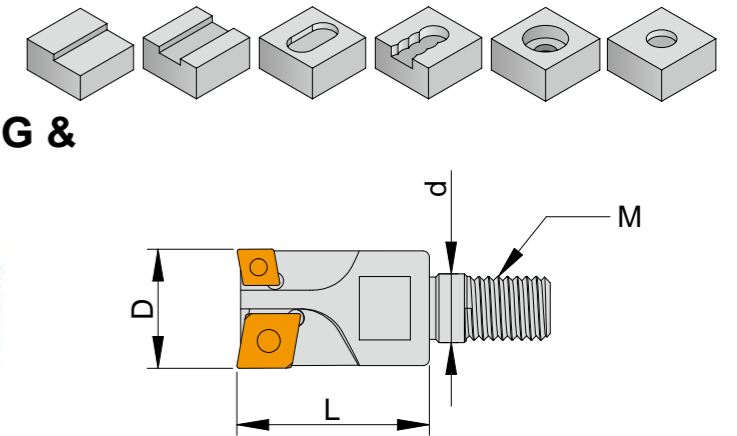

規格表 Specification

型號 Model	D	d	L	M	T	刀片類型 Inserts	螺絲 Screw	扳手 Wrench
AJU16-2T-M08	16	8.5	43	M08	2	CPMT080204Z CCMT060204	TS2505	T08
AJU17-2T-M08	17							
AJU20-2T-M10	20	10.5	50	M10		CPMT090204Z CCMT060204	TS2504 TS3505	T08 T15
AJU21-2T-M10	21							
AJU25-2T-M12	25	12.5	57	M12		CPMT120308Z CPMT090308	TS4004	T15
AJU26-2T-M12	26							
AJU32-2T-M16	32	17	63	M16		CPMT160408Z CPMT120408	TS5007	T20
AJU33-2T-M16	33							

Unit: mm

BCF 球型粗銑刀
BALL NOSE ROUGH
MILLING CUTTER

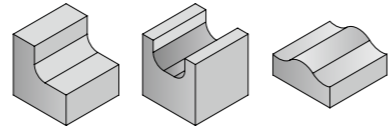
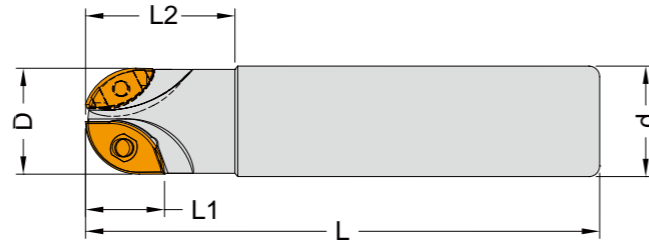

規格表 Specification

型號 Model	D	d	L1	L2	L	T	刀片類型 Inserts	螺絲 Screw	扳手 Wrench
BCF1618S16-130	16	16	18	35	130	2	ZCET080CE ZCET080SE	TS2515	T08
BCF1618S20-180	16	20	18	50	180	2	ZCET100CE ZCET100SE	TS3006	T10
BCF2018S25-140	20	25	18	52	140	2	ZCET125CE ZCET125SE	TS4004	T15
BCF2018S25-200	20	25	18	52	200	2	ZCET150CE ZCET150SE	TS5001	T20
BCF2523S25-150	25	25	23	62	150	2	ZCET160CE ZCET160SE	TS5001	T20
BCF2523S32-200	25	32	23	97	200	2			
BCF3028S32-160	30	32	28	72	160	2			
BCF3028S32-250	30	32	28	92	250	2			
BCF3228S32-160	32	32	28	50	160	2			
BCF3228S32-250	32	32	28	80	250	2			

Unit: mm

BCF 鎖牙式球型粗銑刀
THREADED BALL NOSE
ROUGH MILLING CUTTER

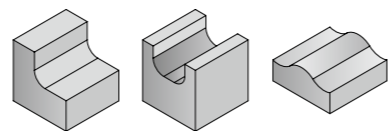
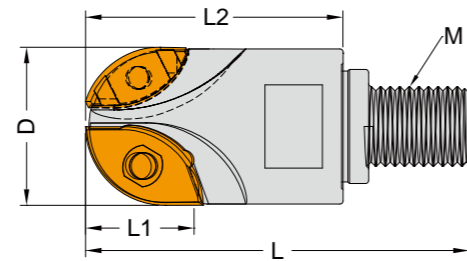

規格表 Specification

型號 Model	D	d	L1	L2	L	T	M	刀片類型 Inserts	螺絲 Screw	扳手 Wrench
BCF16-M08-2	16	15	18	32	49	2	M8	ZCET080CE ZCET080SE	TS2515	T08
BCF20-M10-2	20	18	18	38	57	2	M10	ZCET100CE ZCET100SE	TS3006	T10
BCF25-M12-2	25	23	23	38	60	2	M12	ZCET125CE ZCET125SE	TS4004	T15
BCF30-M12-2	30	25	28	42	64	2	M12	ZCET150CE ZCET150SE	TS5001	T20
BCF32-M16-2	32	30	28	43	66	2	M16	ZCET160CE ZCET160SE	TS5001	T20

Unit: mm

ABPF 精修球刀
FINISHING BALL NOSE
MILLING CUTTER

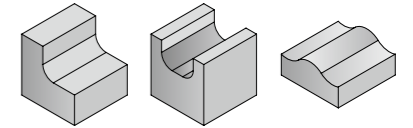
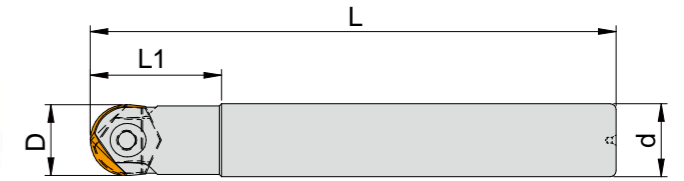

規格表 Specification

型號 Model	D	d	L1	L	刀片類型 Inserts	螺絲 Screw	扳手 Wrench
ABPF0810-130	8	10	30	130	ZPFG080	BR-4R	T08
ABPF1010-130	10	10	30	130	ZPFG100	BR-5R	T08
ABPF1212-130	12	12	30	130	ZPFG120	BR-6R	T10
ABPF1616-150	16	16	30	150	ZPFG160	BR-8R	T20
ABPF2020-160	20	20	45	160	ZPFG200	BR-10R	T20
ABPF2525-180	25	25	45	180	ZPFG250	BR-12.5R	T30
ABPF3025-200	30	25	40	200	ZPFG300	BR-15R	T30
ABPF3232-200	32	32	80	200	ZPFG320	BR-15R	T30

Unit: mm

ABPF 鎖牙式精修球刀
THREADED FINISHING BALL
NOSE MILLING CUTTER

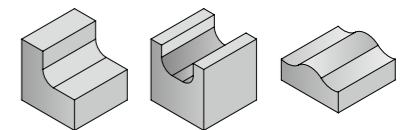
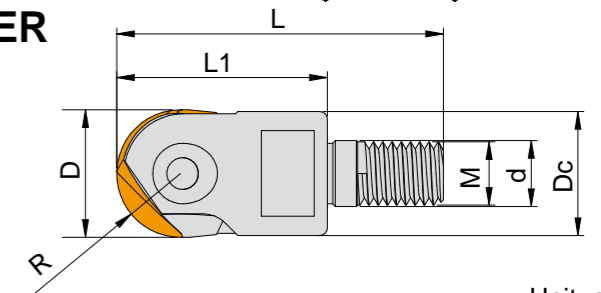

規格表 Specification

型號 Model	D	Dc	d	L1	L	R	M	刀片類型 Inserts	螺絲 Screw	扳手 Wrench
ABPF10-M05	10	9	5.5	20	33	5	M05	ZPFG100	BR-5R	T08
ABPF12-M06	12	11	6.5	22	36	6	M06	ZPFG120	BR-6R	T10
ABPF16-M08	16	15	8.5	28	45	8	M08	ZPFG160	BR-8R	T15
ABPF20-M10	20	18	10.5	30	49	10	M10	ZPFG200	BR-10R	T20
ABPF25-M12	25	23	12.5	40	62	12.5	M12	ZPFG250	BR-12.5R	T30
ABPF30-M16	30	28	17	41	64	15	M16	ZPFG300	BR-15R	T30
ABPF32-M16	32	32	17	41	64	16	M16	ZPFG320	BR-15R	T30

Unit: mm

ABRFM 鎖牙式精修圓鼻刀
THREADED FINISHING BALL MILLING CUTTER

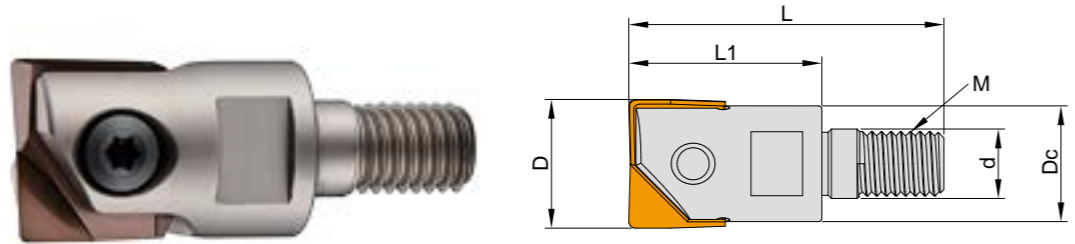
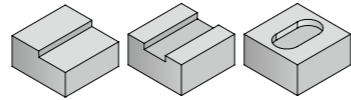

規格表 Specification

Unit: mm

型號 Model	D	Dc	d	L1	L	M	刀片類型 Inserts	螺絲 Screw	板手 Wrench
ABRFM10-M05	10	9	5.5	20	33	M05	ZCFW100	BR-5R	T08
ABRFM12-M06	12	11	6.5	22	36	M06	ZCFW120	BR-6R	T20
ABRFM16-M08	16	14	8.5	28	45	M08	ZCFW160	BR-8R	T20
ABRFM20-M10	20	18	10.5	30	49	M10	ZCFW200	BR-10R	T25
ABRFM25-M12	25	22	12.5	40	62	M12	ZCFW250	BR-12.5R	T30
ABRFM30-M12	30	26	17	41	64	M16	ZCFW300	BR-15R	T30

SPVM 鎖牙式多功能銑刀
THREADED MULTI-FUNCTION MILLING CUTTER

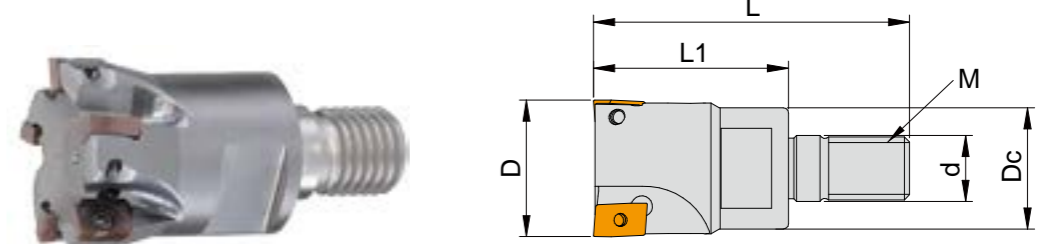
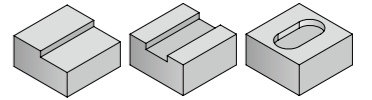

規格表 Specification

Unit: mm

型號 Model	D	d	L2	L	T	刀片類型 Inserts	螺絲 Screw	板手 Wrench
SPVM2017-M08-2	17	8.5	25	42	2	MPHW0603..ZEL	TS2515	T08
SPVM2021-M10-2	21	10.5	30	49	3			
SPVM2026-M12-4	26	12.5	35	57	4			

SPVS 多功能銑刀
MULTI-FUNCTION MILLING CUTTER

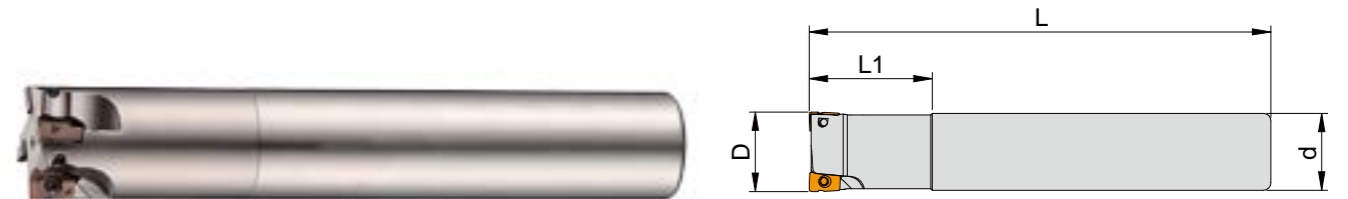
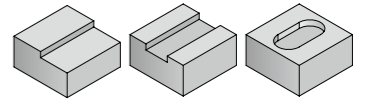

規格表 Specification

Unit: mm

型號 Model	D	d	L2	L	T	刀片類型 Inserts	螺絲 Screw	板手 Wrench
SPVS2017-150-2	17	16	30	150	2	MPHW0603..ZEL	TS2515	T08
SPVS2021-150-3	21	20	30	150	3			
SPVS2021-160-3	21	20	30	160	3			
SPVS2026-150-4	26	25	40	150	4			

SBT 粗球刀
BALL NOSE ROUGH
MILLING CUTTER

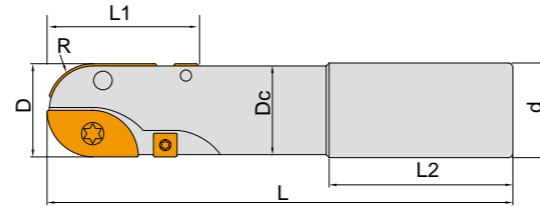
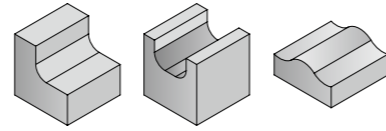

規格表 Specification

型號 Model	D	Dc	d	L	L1	L2	R	刀片類型 Inserts	螺絲 Screw	板手 Wrench		
SBT2030S-150	20	18.7	20	150	30	80	10	SWB220HM x1	TS3006	TK10		
SBT2030L-200				200		100		ZCMT100308Rx2			TS2515	TK08
SBT2535S-150	25	23.5	25	150	35	80	12.5	SWB225HM x1	TS4005	TK15		
SBT2535L-200				200		100		ZCMT100308Rx2			TS2515	TK08
SBT3041S-150	30	28.3	32	150	41	80	15	SWB230HM x1	TS5002	TK20		
SBT3041L-250				250		100		HWB230HS x1			TS4009	TK15
SBT3242S-150	32	29.3	32	150	42	80	16	SWB232HM x1	TS5011	TK20		
SBT3242L-250				250		190		HWB232HS x1			TS4009	TK15
SBT4050S-200	40	36.9	50.8	200	50	100	20	SWB240HM x1	TS6005	TK25		
SBT4050E-250				250		100		HWB240HS x1			TS4009	TK15
SBT4050L-300				300		100		SPGA090304x2				
SBT5060S-200	50	47.9	50.8	200	60	100	25	SWB250HM x1	TS6003	TK30		
SBT5060E-250				250		100		HWB250HS x1			TS5004	TK20
SBT5060L-300				300		100		IM-SP42GSx2				
SBT5060L-350				350		100						

Unit: mm

SKSD 殼型高速進給銑刀
SHELL TYPE HIGH SPEED
FEED MILLING CUTTER

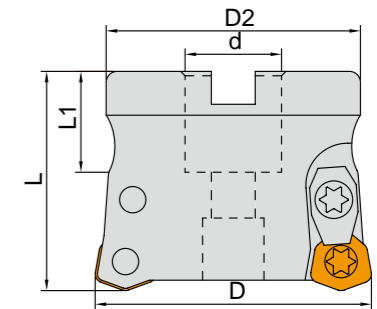
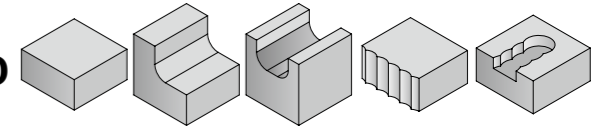

規格表 Specification

型號 Model	D	d	D2	L	L1	T	刀片類型 Inserts	螺絲 Screw	板手 Wrench	壓板 Clamp	壓板螺絲 Screw
SKSD08-05004R-22	50	22	45	50	23	4	WDMW080520ZTR WDHW080520ZTR	TS4502	TK20	DF-8R	TS4502
SKSD08-06304R-22	63	22	58	50	23	4					
SKSD08-08005R-27	80	27	80	55	26	5					
SKSD08-10006R-32	100	32	80	55	32	6					
SKSD08-06304R-22	63	22	58	50	23	4	WDMW10X620ZTR WDHW10X620ZTR	TS5006	TK20	DF-8R	TS4502
SKSD08-08005R-27	80	27	80	55	26	5					
SKSD08-10006R-32	100	32	80	55	32	6					

Unit: mm

PPH 精修球刀
FINISHING BALL NOSE
MILLING CUTTER



規格表 Specification Unit: mm

型號 Model	D	d	L1	L	R	刀片類型 Inserts	螺絲 Screw	板手 Wrench
PPH1010-130	10	10	30	130	5	BNM-100	PH05	T08
PPH1212-130	12	12	30	130	6	BNM-120	PH06	T10
PPH1616-150	16	16	30	150	8	BNM-160	PH08	T15
PPH2020-160	20	20	45	160	10	BNM-200	PH10	T20
PPH2525-180	25	25	45	180	12.5	BNM-250	PH12	T30
PPH3025-200	30	25	40	200	15	BNM-300	PH16	T30
PPH3232-200	32	32	80	200	16	BNM-320	PH16	T30

PPHT 精修圓鼻刀
FINISHING BALL
MILLING CUTTER



規格表 Specification Unit: mm

型號 Model	D	d	L1	L	刀片類型 Inserts	螺絲 Screw	板手 Wrench
PPHT1010-130	10	10	30	130	RNM-100	PH05	T08
PPHT1212-130	12	12	28	130	RNM-120	PH06	T10
PPHT1616-150	16	16	35	150	RNM-160	PH08	T15
PPHT2020-160	20	20	45	160	RNM-200	PH10	T20
PPHT2525-180	25	25	45	180	RNM-250	PH12	T30
PPHT3025-200	30	25	40	200	RNM-300	PH16	T30
PPHT3232-200	32	32	80	200	RNM-320	PH16	T30

PPH 鎖牙式精修球刀
THREADED FINISHING BALL NOSE
MILLING CUTTER

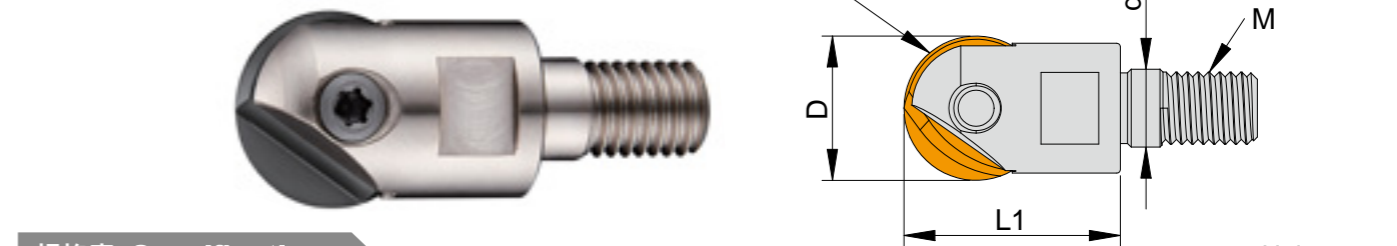

規格表 Specification Unit: mm

型號 Model	D	d	d1	L1	L	M	R	刀片類型 Inserts	螺絲 Screw	板手 Wrench
PPH10-M05	10	5.5	9	20	33	M05	5	BNM-100	PH05	T08
PPH12-M06	12	6.5	11	22	36	M06	6	BNM-120	PH06	T10
PPH16-M08	16	8.5	14	28	45	M08	8	BNM-160	PH08	T15
PPH20-M10	20	10.5	18	30	49	M10	10	BNM-200	PH10	T20
PPH25-M12	25	12.5	22	40	62	M12	12.5	BNM-250	PH12	T30
PPH30-M16	30	17	26	41	64	M16	15	BNM-300	PH16	T30
PPH32-M16	32	17	29	41	64	M16	16	BNM-320	PH16	T30

PPHT 鎖牙式精修圓鼻刀
THREADED FINISHING
BALL MILLING CUTTER

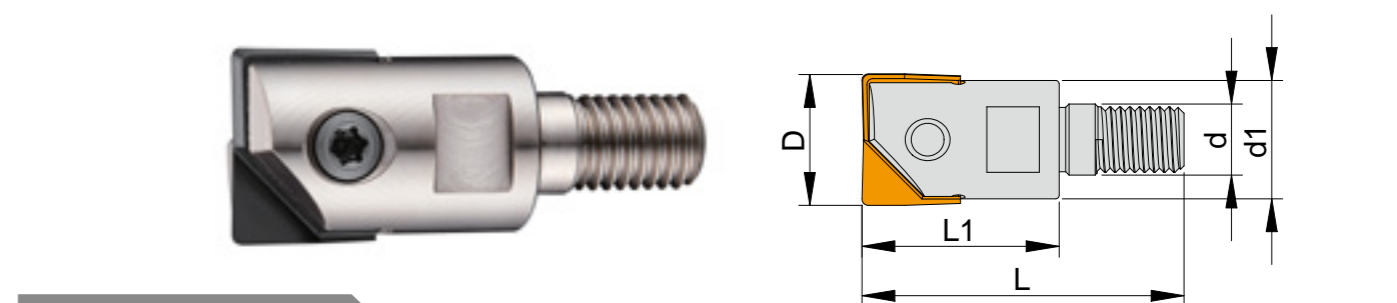

規格表 Specification Unit: mm

型號 Model	D	d	d1	L1	L	M	刀片類型 Inserts	螺絲 Screw	板手 Wrench
PPHT10-M05	10	5.5	9	20	33	M05	RNM-100	PH05	T08
PPHT12-M06	12	6.5	11	22	36	M06	RNM-120	PH06	T10
PPHT16-M08	16	8.5	14	28	45	M08	RNM-160	PH08	T15
PPHT20-M10	20	10.5	18	30	49	M10	RNM-200	PH10	T20
PPHT25-M12	25	12.5	22	40	62	M12	RNM-250	PH12	T30
PPHT30-M16	30	17	26	41	64	M16	RNM-300	PH16	T30
PPHT32-M16	32	17	29	41	64	M16	RNM-320	PH16	T30

JXD 高速進給銑刀
HIGH FEED MILLING CUTTER

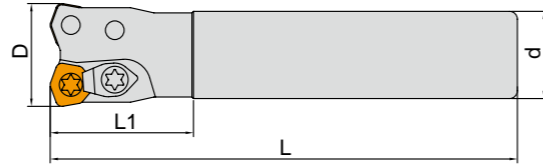
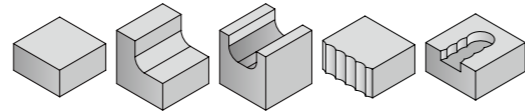

規格表 Specification

型號 Model	D	d	L	L1	T	刀片類型 Inserts	螺絲 Screw	板手 Wrench	壓板 Clamp	壓板螺絲 Screw
JXD06-162R-110	16	16	110	30	2	JOMT060215Z..	TS2515	TK08	AS03	AJ3510
JXD06-162R-150	16	16	150	70	2					
JXD06-172R-150	17	16	150	20	2					
JXD08-202R-130	20	20	130	40	2	JOMT080320Z..	TS3014	TK09	AS04	AJ4012
JXD08-222R-130	22	20	130	40	2					
JXD08-222R-180	22	20	180	35	2					
JXD09-252R-150	25	25	150	35	2	JDMW09T320Z..	TS4016	TK15	AS04	AJ3510
JXD09-252R-220	25	25	220	120	2					
JXD09-262R-150	26	25	150	40	2					
JXD09-282R-150	28	25	150	35	2					
JXD09-282R-200	28	25	200	40	2					
JXD12-302R-150	30	25	150	35	2					
JXD12-322R-150	32	32	150	35	2	JDMW120420Z..	TS4008	TK15	AS04	AJ4012
JXD12-352R-150	35	32	150	35	2					
JXD12-403R-170	40	32	170	47	3					
JXD12-504R-170	50	32	170	50	4					
JXD14-634R-200	63	42	200	50	4					
						JDMW140520Z..	TS5001	TK20	AS05	AJ5014

Unit: mm

JXD 殼型高速進給銑刀
SHELL TYPE HIGH FEED
MILLING CUTTER

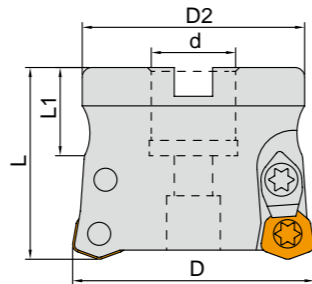
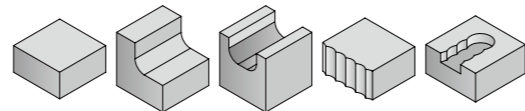

規格表 Specification

型號 Model	D	d	D2	L	L1	T	刀片類型 Inserts	螺絲 Screw	板手 Wrench	壓板 Clamp	壓板螺絲 Screw
JXD12-05004R-22	50	22	45	50	23	4	JDMW120420Z..	TS4008	TK15	AS04	AJ4012
JXD12-06305R-22	63	22	58	50	23	5					
JXD12-08006R-27	80	27	65	55	26	6					
JXD14-06304R-22	63	22	58	50	23	4	JDMW140520Z..	TS5001	TK20	AS05	AJ5014
JXD14-08005R-27	80	27	65	55	26	5					
JXD14-10006R-32	100	32	80	55	32	6					
JXD14-16008R-50.8	160	50.8	125	63	38	8					

Unit: mm

BAP 直角鍵槽端銑刀
ORTHOGONAL KEYWAY
END MILLING CUTTER

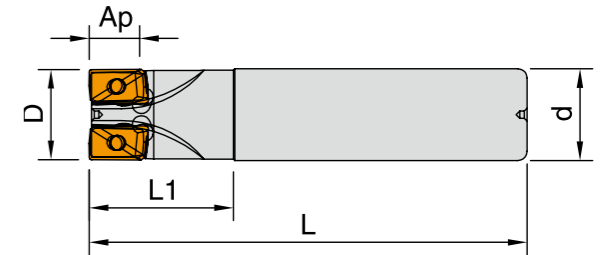
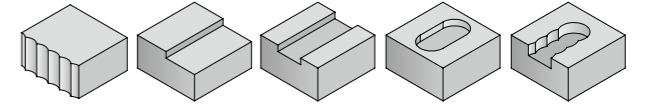

規格表 Specification

型號 Model	D	L	L1	d	T	刀片類型 Inserts	螺絲 Screw	板手 Wrench
BAP300R101SN12S	10	100	22	12	1	APMT1135PDER	TS2515	T08
BAP300R121SN12S	12							
BAP300R141SN12S	14							
BAP300R162SN16S	16		25	16	2			
BAP300R172SN16S	17							
BAP300R182SN16S	18							
BAP300R192SN16S	19	30	20	3				
BAP300R203SN20S	20							
BAP300R213SN20S	21							
BAP300R223SN20S	22							
BAP300R233SN20S	23							
BAP300R243SN20S	24	35	25	4				
BAP300R254SN25S	25							
BAP300R264SN25S	26	120	40	32	5			
BAP300R274SN25S	27							
BAP300R284SN25S	28							
BAP300R294SN25S	29							
BAP300R304SN25S	30							
BAP300R314SN25S	31							
BAP300R325SN32S	32							
BAP300R335SN32S	33							
BAP300R345SN32S	34							
BAP300R355SN32S	35							
BAP300R405SN32S	40	32	32	5				
BAP300R506SN32S	50							

Unit: mm

BAP 直角端銑刀
ORTHOGONAL END
MILLING CUTTER

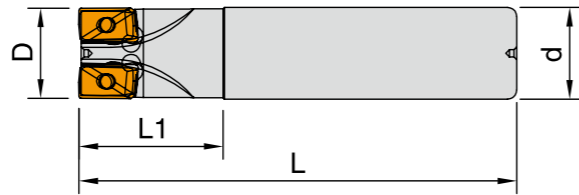
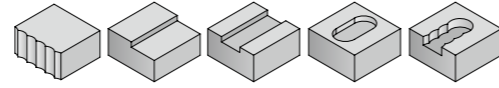

規格表 Specification

Unit: mm

型號 Model	D	L	L1	d	T	刀片類型 Inserts	螺絲 Screw	板手 Wrench
BAP300R121SN12-130	12	130	30	12	1	APMT1135PDER	TS2515	T08
BAP300R162SN16-120	16	120	35	16	2			
BAP300R162SN16-150		150						
BAP300R162SN16-160		160						
BAP300R162SN16-200		200						
BAP300R172SN16-120		120						
BAP300R172SN16-150	150							
BAP300R192SN20-120	19	120	35	20	3			
BAP300R202SN20-120	120							
BAP300R202SN20-150	150							
BAP300R202SN20-200	200							
BAP300R203SN20-120	120							
BAP300R203SN20-150	150							
BAP300R212SN20-150	21	150	40	25	2			
BAP300R212SN20-200		200						
BAP300R213SN20-150		150						
BAP300R253SN25-150		25				150		
BAP300R262SN25-150		150						
BAP300R262SN25-200	26	200	40	32	5			
BAP300R263SN25-150	150							
BAP300R303SN25-250	30	250						
BAP300R323SN32-200	32	200						
BAP300R355SN32-150	35	150						

BAP 直角端銑刀
ORTHOGONAL END
MILLING CUTTER

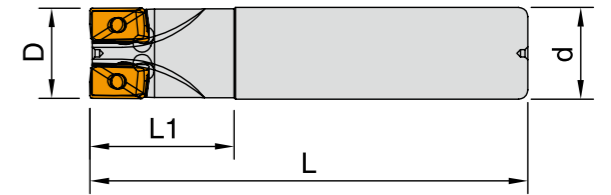
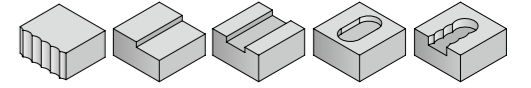

規格表 Specification

Unit: mm

型號 Model	D	L	L1	d	T	刀片類型 Inserts	螺絲 Screw	板手 Wrench			
BAP400R232SN25-140	23	140	40	25	2	APMT1604PDER	TS4023	T15			
BAP400R242SN25-150	24	150									
BAP400R252SN25-150	25	150									
BAP400R252SN25-200		200									
BAP400R252SN25-220		220									
BAP400R252SN25-250		250									
BAP400R252SN25-300		300									
BAP400R262SN25-150	26	150							45	32	3
BAP400R272SN25-150	27	150									
BAP400R302SN25-150	30	150									
BAP400R303SN32-160		160									
BAP400R303SN32-190		190									
BAP400R322SN32-150	32	150	45	32	3						
BAP400R323SN32-150		150									
BAP400R323SN32-250		250									
BAP400R323SN32-300		300									
BAP400R332SN32-150	33	150	45	32	2						
BAP400R333SN32-200		200									
BAP400R353SN32-200		200									
BAP400R353SN32-250	35	250	45	32	3						
BAP400R353SN32-300		300									
BAP400R353SN32-350		350									
BAP400R404SN32-170	40	170	45	32	4						
BAP400R404SN32-200		200									
BAP400R404SN32-300		300									

BAP 殼型直角面銑刀
SHELL TYPE ORTHOGONAL
FACE MILLING CUTTER

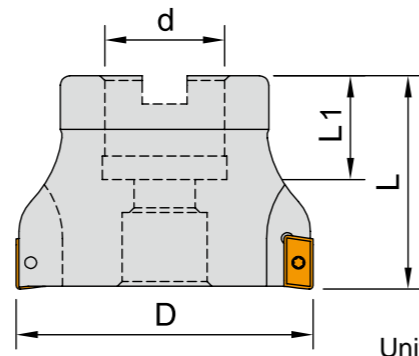
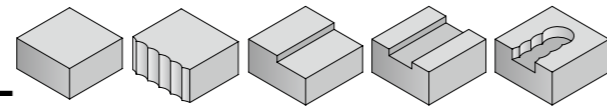

規格表 Specification

型號 Model	D	d	L	L1	T	刀片類型 Inserts	螺絲 Screw	板手 Wrench
BAP300R040-16-5T	40	16	40	18	5	APMT1135PDER	TS2515	T08
BAP300R050-22-6T	50	22	45	22	6			
BAP300R050-25.4-6T	50	25.4		18	7			
BAP300R063-22-7T	63	22	50	22	8			
BAP300R063-25.4-8T	63	25.4		26				
BAP300R080-27-8T	80	27	50	32	10			
BAP300R080-25.4-8T	80	25.4						
BAP300R100-32-10T	100	32	50	32	11			
BAP300R100-21.75-11T	100	31.75						
BAP400R040-16-4T	40	16	40	18	4			
BAP400R050-22-5T	50	22	45	22	5			
BAP400R050-25.4-5T	50	25.4		18	6			
BAP400R063-22-6T	63	22	50	22	5			
BAP400R063-25.4-5T	63	25.4		26	7			
BAP400R080-27-7T	80	27	50	32	8			
BAP400R080-25.4-6T	80	25.4				32		
BAP400R100-32-8T	100	32	50	32	9			
BAP400R100-31.75-8T	100	31.75				36		
BAP400R125-40-9T	125	40	55	36	9			
BAP400R160-40-10T	160	40	63	36	10			
BAP400R160-50.8-10T	160	50.8	63	36	10			

Unit: mm

BAP 鎖牙式直角銑刀
THREADED ORTHOGONAL
MILLING CUTTER

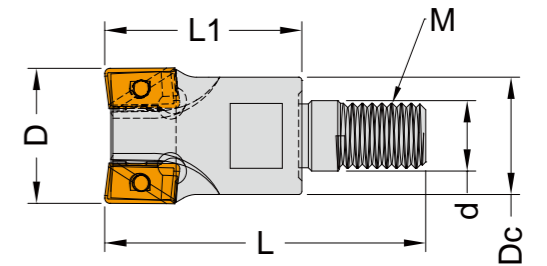
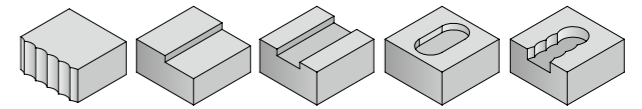

規格表 Specification

型號 Model	D	Dc	L1	L	M	T	d	刀片類型 Inserts	螺絲 Screw	板手 Wrench			
BAP300R162-M08	16	15	26	43	M8	2	8.5	APMT1135PDER	TS2515	T08			
BAP300R172-M08	17	15	26	43	M8	2	8.5						
BAP300R202-M10	20	18	30	49	M10	2	10.5						
BAP300R203-M10	20	18	30	49	M10	3	10.5						
BAP300R212-M10	21	18	30	49	M10	2	10.5						
BAP300R213-M10	21	18	30	49	M10	3	10.5						
BAP300R253-M12	25	23	35	57	M12	2	12.5						
BAP300R254-M12	25	23	35	57	M12	4	12.5						
BAP300R264-M12	26	23	35	57	M12	4	12.5						
BAP300R323-M16	32	30	40	63	M16	3	16.5						
BAP300R325-M16	32	30	40	63	M16	5	16.5						
BAP300R333-M16	33	30	40	63	M16	3	16.5						
BAP300R335-M16	33	30	40	63	M16	5	16.5						
BAP400R252-M12	25	23	35	57	M12	2	12.5				AP...1604PDER	TS4023	T15
BAP400R262-M12	26	23	35	57	M12	2	12.5						
BAP400R302-M12	30	23	35	57	M12	2	12.5						
BAP400R323-M16	32	30	40	63	M16	3	16.5						
BAP400R333-M16	33	30	40	63	M16	3	16.5						
BAP400R353-M16	35	30	40	63	M16	3	16.5						

Unit: mm

BAP BT 整體式銑刀
BT MILLING CUTTER HOLDER

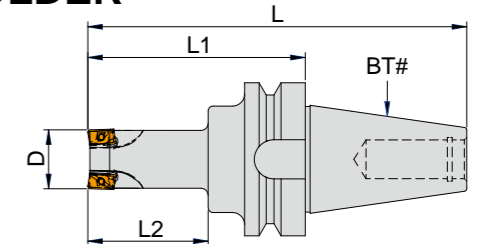
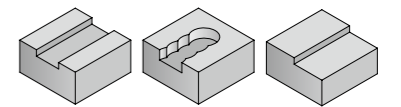

Unit: mm

型號 Model	D	L1	L2	L	T	刀片類型 Inserts	螺絲 Screw	板手 Wrench
BT30-BAP300R203-80	20	35	80	129	3	APMT1135PDER	TS2515	T08
BT30-BAP300R253-80	25	45	80	129	3			
BT40-BAP300R203-90	20	35	90	156	3			
BT40-BAP300R253-90	25	40	90	156	3			

BAP 粗銑刀
ROUGH CUTTING
MILLING CUTTER

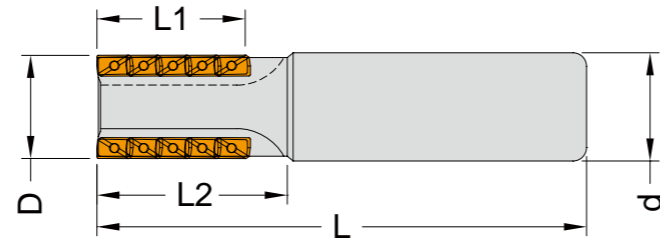
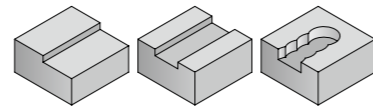

規格表 Specification

Unit: mm

型號 Model	D	d	L1	L2	L	T	刀片類型 Inserts	螺絲 Screw	板手 Wrench
BAP300R2005S20-028L	20	20	28	42	107	1x5	APMT1135PDER	TS2515	T08
BAP300R2508S25-035L	25	25	35	50	125	2x4			
BAP300R3215S32-044L	32	32	44	60	135	3x5			
BAP300R4024S32-072L	40	32	72	94	175	3x8			
BAP400R3206S32-042L	32	32	42	63	135	2x3	APMT1604PDER	TS4023	T15
BAP400R4010S32-068L	40	32	68	94	175	2x5			
BAP400R4015S32-068L	40	32	68	94	175	3x5			
BAP400R5024S50.8-100L	50	50.8	100	128	224	3x8			
BAP400R5036S50.8-158L	50	50.8	158	188	284	3x12			

BAP 殼型粗銑刀
SHELL TYPE ROUGH
MILLING CUTTER

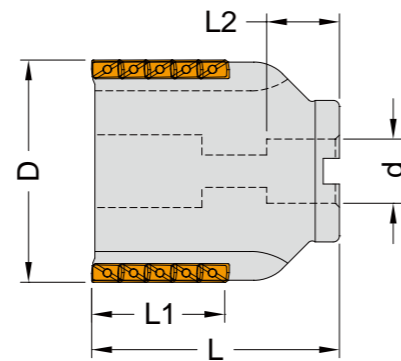
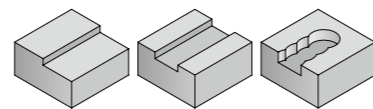

規格表 Specification

Unit: mm

型號 Model	D	d	L1	L2	L	T	刀片類型 Inserts	螺絲 Screw	板手 Wrench
BAP400R05009-42-22.0	50	22	42	21	69	3x3	APMT1604PDER	TS4023	T15
BAP400R06312-42-25.4	63	25.4	42	38	69	4x3			
BAP400R06320-68-25.4	63	25.4	68	38	97	4x5			

RAP 殼型平面銑刀
SHELL TYPE FACE MILLING CUTTER

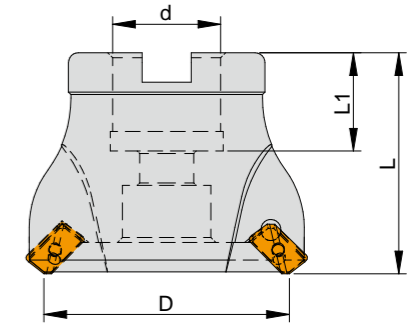
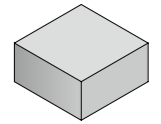

規格表 Specification

Unit: mm

型號 Model	D	d	L2	L	T	刀片類型 Inserts	螺絲 Screw	板手 Wrench
RAP300R050-22-4T	50	22	22	45	4	AP..1135PDER	TS2515	T08
RAP300R063-22-5T	63	22	22	45	5			

RAP 殼型平面銑刀
SHELL TYPE FACE MILLING CUTTER

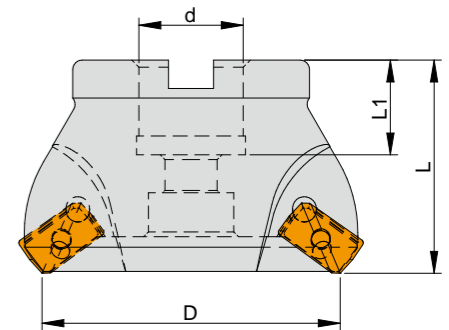
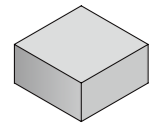

規格表 Specification

Unit: mm

型號 Model	D	d	L2	L	T	刀片類型 Inserts	螺絲 Screw	板手 Wrench
RAP400R063-22-4T	63	22	22	45	4	AP..1604PDER	TS4023	T15
RAP400R080-27-5T	80	27	25	50	5			

AQXR 短刃型鑽銑刀
SHORT INSERT
DRILLING & MILLING CUTTER

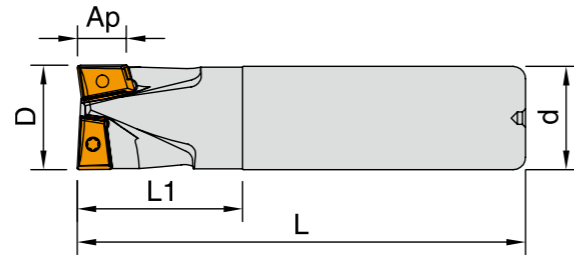
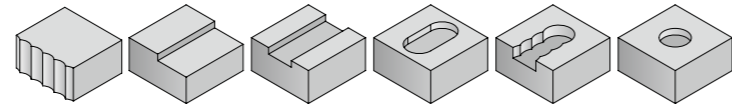

規格表 Specification

Unit: mm

總類	型號 Model	D	L	L1	d	AP	刀片類型 Inserts	螺絲 Screw	板手 Wrench
STANDARD 標準型	AQXR162SN16S	16	120	30	16	7	QO...0830R-...	TS2006	T06
	AQXR172SN16S	17							
	AQXR202SN20S	20	130	35	20	9	QO...1035R-...	TS2512	T08
	AQXR212SN20S	21							
	AQXR252SN25S	25	140	40	25	11	QO...1342R-...	TS3011	T08
	AQXR262SN25S	26							
	AQXR322SN32S	32	150	50	32	14	QO...1651R-...	TS4016	T15
	AQXR332SN32S	33							
	AQXR352SN32S	35							
	AQXR402SN32S	40	160	60	32	17	QO...2062-...	TS5010	T25
	AQXR502SN42S	50	170	70	42	22	QO...2576-...	TS6003	T30
	EXTRA LONG 加長型	AQXR162SN16L	16	175	30	16	7	QO...0830R-...	TS2006
AQXR172SN16L		17							
AQXR202SN20L		20	185	35	20	9	QO...1035R-...	TS2512	T08
AQXR212SN20L		21							
AQXR252SN25L		25	220	40	25	11	QO...1342R-...	TS3011	T08
AQXR262SN25L		26							
AQXR322SN32L		32	230	50	32	14	QO...1651R-...	TS4016	T15
AQXR332SN32L		33							
AQXR352SN32L		35							
AQXR402SN32L		40	240	60	32	17	QO...2062-...	TS5010	T25
AQXR502SN42L		50	250	70	42	22	QO...2576-...	TS6003	T30

AQXR 長刃型鑽銑刀
LONG INSERT
DRILLING & MILLING CUTTER

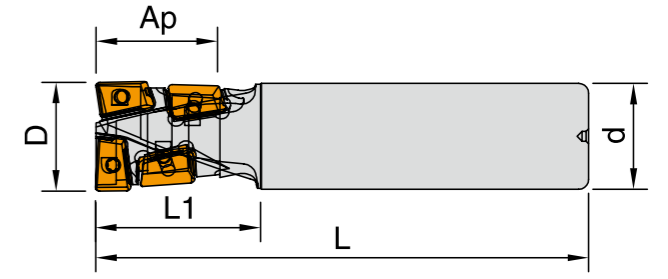
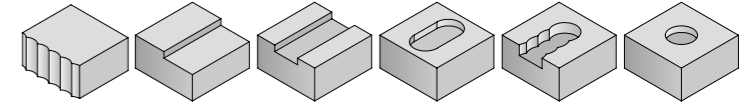

規格表 Specification

Unit: mm

總類	型號 Model	D	L	L1	d	AP	刀片類型 Inserts	螺絲 Screw	板手 Wrench
STANDARD 標準型	AQXR164SN16S	16	120	30	16	17	QO...0830R-...	TS2006	T06
	AQXR174SN16S	17							
	AQXR204SN20S	20	130	35	20	22	QO...1035R-...	TS2512	T08
	AQXR214SN20S	21							
	AQXR254SN25S	25	140	40	25	27	QO...1342R-...	TS3011	T08
	AQXR264SN25S	26							
	AQXR324SN32S	32	150	50	32	35	QO...1651R-...	TS4016	T15
	AQXR334SN32S	33							
	AQXR354SN32S	35							
	AQXR404SN32S	40	160	60	32	44	QO...2062-...	TS5010	T25
	AQXR504SN42S	50	170	70	42	55	QO...2576-...	TS6003	T30
	EXTRA LONG 加長型	AQXR164SN16L	16	175	30	16	17	QO...0830R-...	TS2006
AQXR174SN16L		17							
AQXR204SN20L		20	185	35	20	22	QO...1035R-...	TS2512	T08
AQXR214SN20L		21							
AQXR254SN25L		25	220	40	25	27	QO...1342R-...	TS3011	T08
AQXR264SN25L		26							
AQXR324SN32L		32	230	50	32	35	QO...1651R-...	TS4016	T15
AQXR334SN32L		33							
AQXR354SN32L		35							
AQXR404SN32L		40	240	60	32	44	QO...2062-...	TS5010	T25
AQXR504SN42L		50	250	70	42	55	QO...2576-...	TS6003	T30

BRP 圓刃端銑刀
ROUND INSERT END MILL

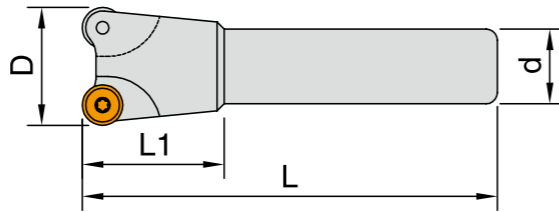
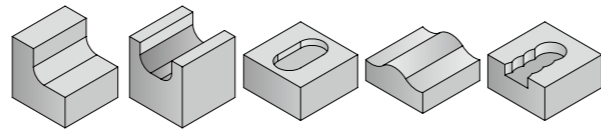

規格表 Specification

Unit: mm

總類	型號 Model	D	L	L1	d	T	刀片類型 Inserts	螺絲 Screw	板手 Wrench
STANDARD 標準型	BRP4NR121SN12-100	12	100	30	12	1	RPMW08T2MO RPMT08T2MOE-JS	TS3004	T09
	BRP4NR162SN16-150	16	150	50	16	2			
	BRP4NR202SN20-150	20	150	50	20	2			
	BRP4NR253SN25-150	25	150	40	25	3	RPMW10T3MO RPMT10T3MOE-JS	TS3503	T15
	BRP5NR252SN25-150	25				2			
	BRP5NR303SN25-150	30				3			
	BRP5NR323SN32-150	32				3			
	BRP5NR353SN32-150	35				3			
	BRP6NR322SN32-170	32	170	45	32	2	RPMW1204MO RPMT1204MOE-JS	TS4006	T15
	BRP6NR403SN32-170	40				3			
	BRP6NR504SN42-170	50				4			
	EXTRA LONG 加長型	BRP4NR162SN16-150	16	150	50	16	RPMW08T2MO RPMT08T2MOE-JS	TS3004	T09
BRP4NR202SN20-200		20	200	20		2			
BRP4NR202SN20-250		20	250	50	25	3	RPMW10T3MO RPMT10T3MOE-JS	TS3503	T15
BRP5NR253SN25-200		25	200						
BRP5NR252SN25-200		25	200						
BRP5NR252SN25-250		25	250						
BRP5NR303SN25-200		30	200						
BRP5NR323SN32-200		32	200						
BRP5NR323SN32-250		32	250						
BRP5NR353SN32-200		35	200						
BRP5NR322SN32-230		32	230						
BRP6NR322SN32-250		32	250						
BRP6NR403SN32-230		40	230	50	32	2	RPMW1204MO RPMT1204MOE-JS	TS4006	T15
BRP6NR504SN42-230		50	230						
			42	4					

BRP 殼型圓刃面銑刀
SHELL TYPE ROUND
INSERT FACE MILLING CUTTER

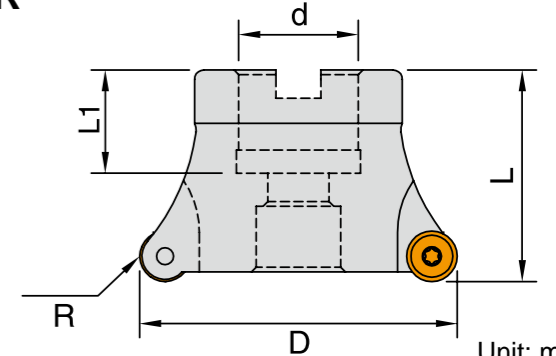
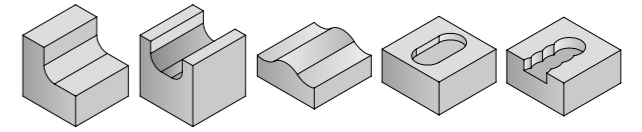

Unit: mm

規格表 Specification

型號 Model	D	d	L	L1	T	R	刀片類型 Inserts	螺絲 Screw	板手 Wrench
BRP4NR040-16-5T	40	16	40	18	5	4	RPMW08T2MO RPMT08T2MOE-JS	TS3004	T09
BRP4NR050-22-6T	50	22	45	22	6				
BRP5NR040-16-4T	40	16	40	18	4	5	RPMW10T3MO RPMT10T3MOE-JS	TS3503	T15
BRP5NR050-22-5T	50	22	45	22	5				
BRP5NR050-25.4-5T	50	25.4			6				
BRP5NR063-22-6T	63	22			6				
BRP5NR063-25.4-5T	63	25.4			6				
BRP6NR050-22-4T	50	22	45	22	4	6	RPMW1204MO RPMT1204MOE-JS	TS4006	T15
BRP6NR050-25.4-4T	50	25.4							
BRP6NR063-22-5T	63	22							
BRP6NR063-25.4-5T	63	25.4							
BRP6NR080-25.4-6T	80	25.4	50	26	6	8	RPMW1606MO RPMT1606MOE-JS	TS5002	T20
BRP6NR080-27-6T	80	27							
BRP8NR063-22-4T	63	22	45	22	4	8	RPMW1606MO RPMT1606MOE-JS	TS5002	T20
BRP8NR063-25.4-4T	63	25.4							
BRP8NR080-25.4-5T	80	25.4	50	26	5	8	RPMW1606MO RPMT1606MOE-JS	TS5002	T20
BRP8NR080-27-5T	80	27							
BRP8NR100-31.75-6T	100	31.75	50	32	6	8	RPMW1606MO RPMT1606MOE-JS	TS5002	T20
BRP8NR100-32-6T	100	32							

ASX445R/L

45° 右/左旋殼型平面銑刀
45° SHELL TYPE FACE MILLING CUTTER

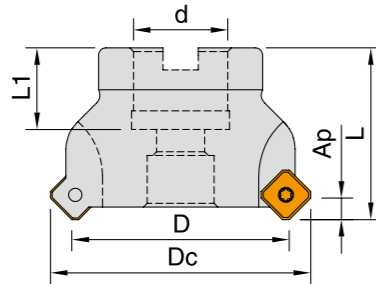
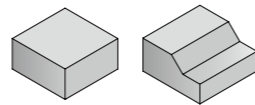

墊片 Shim	牙套 Screw	螺絲 Screw	板手 Wrench	板手 Wrench
AS445N	PS35T	TS3505	T15	T20

規格表 Specification

Unit: mm

型號 Model	D	Dc	d	L	L1	T	Ap	刀片類型 Inserts
ASX445R050-22-4T	50	63.0	22	40	20	4	5.5	JIS SE..13T3AGEN-.. ISO SE..12T3AGSN-..
ASX445R063-22-5T	63	75.9	22			5		
ASX445R063-25.4-5T			25.4	5				
ASX445R080-27-6T	80	93.2	27	50	26	6		
ASX445R080-25.4-6T			25.4			6		
ASX445R100-32-7T	100	113.2	32	63	32	7		
ASX445R100-31.75-7T			31.75			7		
ASX445R125-40-8T	125	138.0	40	63	38	8		
ASX445R125-38.1-8T			38.1			8		
ASX445R160-40-10T	160	173.0	40	63	38	10		
ASX445R160-50.8-10T			50.8			10		
ASX445R200-60-12T	200	212.9	60	63	38	12		
ASX445R200-47.625-12T			47.625			12		
ASX445R250-60-14T	250	262.9	60	63	38	14		
ASX445R250-47.625-14T			47.625			14		
ASX445R315-47.625-14T	315	327.9	47.625	63	38	14		

型號 Model	D	Dc	d	L	L1	T	Ap	刀片類型 Inserts
ASX445L050-22-4T	50	63.0	22	40	20	4	5.5	JIS SE..13T3AGEN-.. ISO SE..12T3AGSN-..
ASX445L063-22-5T	63	75.9	22			5		
ASX445L063-25.4-5T			25.4	5				
ASX445L080-27-6T	80	93.2	27	50	26	6		
ASX445L080-25.4-6T			25.4			6		
ASX445L100-32-7T	100	113.2	32	63	32	7		
ASX445L100-31.75-7T			31.75			7		
ASX445L125-40-8T	125	138.0	40	63	38	8		
ASX445L125-38.1-8T			38.1			8		
ASX445L160-40-10T	160	173.0	40	63	38	10		
ASX445L160-50.8-10T			50.8			10		
ASX445L200-60-12T	200	212.9	60	63	38	12		
ASX445L200-47.625-12T			47.625			12		
ASX445L250-60-14T	250	262.9	60	63	38	14		
ASX445L250-47.625-14T			47.625			14		
ASX445L315-47.625-14T	315	327.9	47.625	63	38	14		

ASX400R

直角端銑刀
ORTHOGONAL END MILLING CUTTER

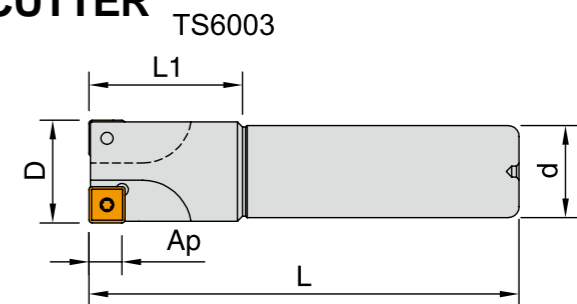
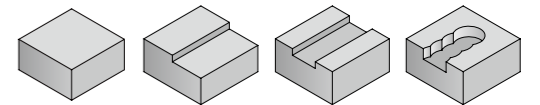

規格表 Specification

Unit: mm

型號 Model	D	d	L	L1	T	Ap	刀片類型 Inserts
ASX400R403SN32S-125	40	32	125	40	3	10	SOMT/ET/GT 12T3PEER-
ASX400R504SN32S-125	50				4		
ASX400R635SN32S-125	63				5		

ASX400R

殼型直角面銑刀
SHELL TYPE FACE MILLING CUTTER

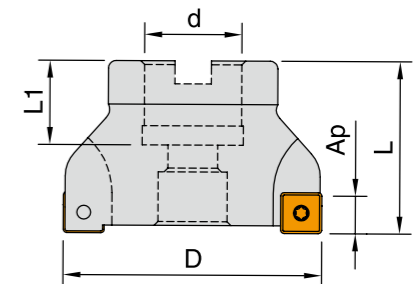
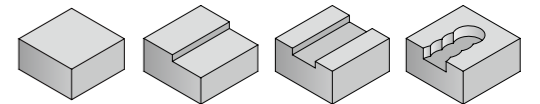

規格表 Specification

Unit: mm

型號 Model	D	d	L	L1	T	Ap	刀片類型 Inserts
ASX400R05004-22	50	22	40	20	4	10	SOMT/ET/GT 12T3PEER-
ASX400R06305-22	63				5		
ASX400R08005-27	80	27	50	26	5		
ASX400R08005-25.4		25.4			5		
ASX400R10006-32	100	32	63	32	6		
ASX400R10006-31.75		31.75			6		
ASX400R12508-38.1	125	38.1	63	38	8		
ASX400R12508-40		40			8		
ASX400R16010-40	160	40	63	38	10		

墊片 Shim	牙套 Screw	螺絲 Screw	板手 Wrench	板手 Wrench
AS400N	PS35T	TS3505	T15	T20

APX30R 高進給端銑刀
HIGH FEED END MILLING CUTTER

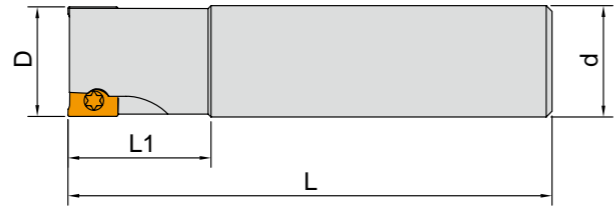
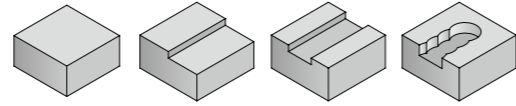

Unit: mm

規格表 Specification

類型	型號 Model	D	d	L2	L	T	刀片類型 Inserts	螺絲 Screw	板手 Wrench
STANDARD 標準型	APX30R121S16	12	16	25	85	1	AOMT123608 AOMT1236PDER AOGT1236PDER	TS2515	T08
	APX30R141S16	14	16	25	85	1			
	APX30R162S16	16	16	25	85	2			
	APX30R182S16	18	16	25	85	2			
	APX30R202S20	20	20	30	100	2			
	APX30R203S20	20	20	30	100	3			
	APX30R222S20	22	20	30	115	2			
	APX30R252S25	25	25	35	115	2			
	APX30R253S25	25	25	35	115	3			
	APX30R254S25	25	25	35	115	4			
	APX30R284S25	28	25	35	115	4			
	APX30R304S32	30	32	45	125	4			
	APX30R323S32	32	32	45	125	3			
	APX30R324S32	32	32	45	125	4			
	APX30R325S32	32	32	45	125	5			
LONG 加長型	APX30R162S16L	16	16	25	120	2	AOMT123608 AOMT1236PDER AOGT1236PDER	TS2515	T08
	APX30R182S16L	18	16	25	120	2			
	APX30R202S20L	20	20	30	150	2			
	APX30R222S20L	22	20	30	150	2			
	APX30R252S25L	25	25	35	170	2			
	APX30R253S25L	25	25	35	170	3			
	APX30R282S25L	28	25	35	170	3			
EXTRA LONG 超長型	APX30R323S32L	32	32	45	190	3	AOMT123608 AOMT1236PDER AOGT1236PDER	TS2515	T08
	APX30R353S32L	35	32	45	190	3			
	APX30R162S16E	16	16	25	180	2			
	APX30R182S16E	18	16	25	180	2			
	APX30R202S20E	20	20	30	200	2			
	APX30R222S20E	22	20	30	200	2			
	APX30R252S25E	25	25	35	220	2			
	APX30R253S25E	25	25	35	220	3			
	APX30R283S25E	28	25	35	220	3			
	APX30R323S32E	32	32	45	260	3			
APX30R353S32E	35	32	45	260	3				

APX30R 直角面銑刀
ORTHOGONAL FACE MILLING CUTTER

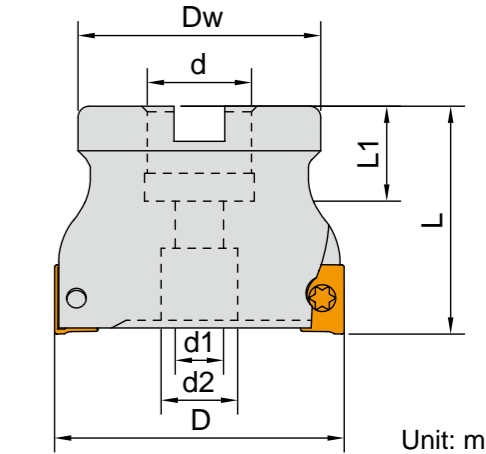
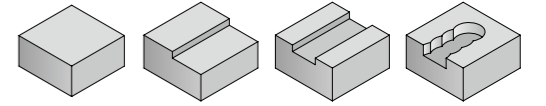

Unit: mm

規格表 Specification

型號 Model	D	d	L1	L	Dw	d1	d2	T	刀片類型 Inserts	螺絲 Screw	板手 Wrench
APX30R05007-22	50	22	20	40	45	11	17	7	AOMT1236PEER AOGT1236PEFR	TS2515	T08
APX30R06308-22	63	22	20	40	50	11	17	8			
APX30R08009-25.4	80	25.4	26	50	70	13	20	9			
APX30R10011-31.75	100	31.75	32	63	80	17	26	11			

APX30R BT整體式銑刀
BT HOLDER MILLING CUTTER

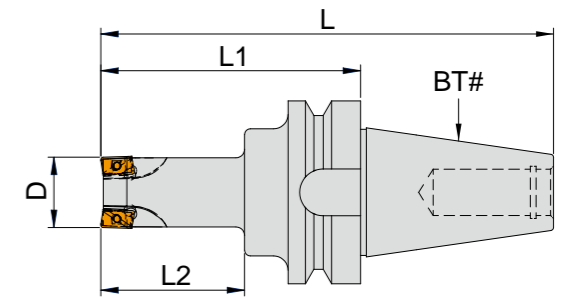
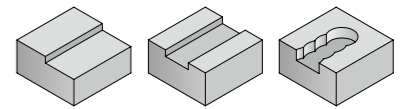

Unit: mm

規格表 Specification

型號 Model	D	L1	L2	L	T	刀片類型 Inserts	螺絲 Screw	板手 Wrench
BT30-APX30R203-80	20	35	80	129	3	AOMT1236..PEER-.. AOGT1236..PEER-..	TS2515	T08
BT30-APX30R253-80	25	45	80	129	3			
BT40-APX30R203-90	20	35	90	156	3			
BT40-APX30R253-90	25	40	90	156	3			

APX40R 直角銑刀
ORTHOGONAL MILLING CUTTER

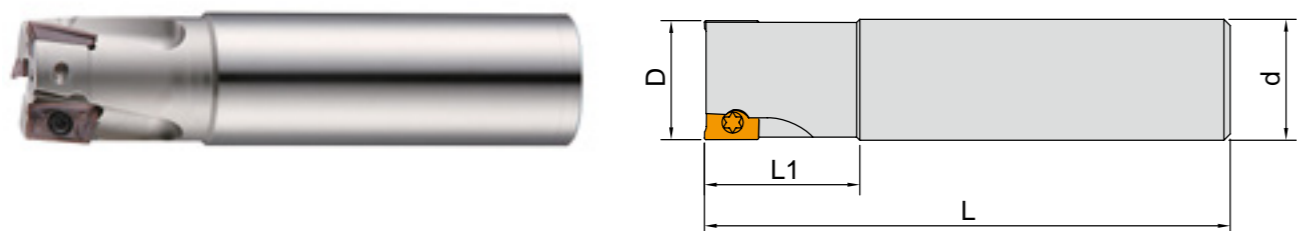
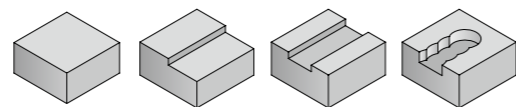

規格表 Specification

型號 Model	D	d	L1	L	T	刀片類型 Inserts	螺絲 Screw	板手 Wrench
APX40R252S25	25	25	35	125	2	AOMT1848...	TS4002	T15
APX40R323S32	32	32	45	135	3		TS4023	
APX40R353S32	35	32	45	135	3			
APX40R403S32	40	32	45	135	3			
APX40R404S32	40	32	45	135	4			

Unit: mm

APX40R 直角面銑刀
ORTHOGONAL FACE MILLING CUTTER

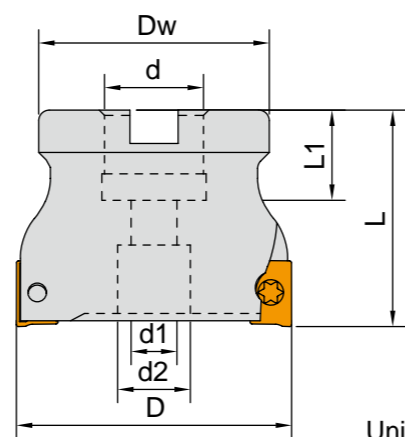
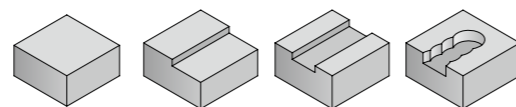

規格表 Specification

型號 Model	D	d	L1	L	Dw	d1	d2	T	刀片類型 Inserts	螺絲 Screw	板手 Wrench
APX40R05005-22	50	22	20	40	45	11	17	5	AOMT1848...	TS4002	T15
APX40R06306-22	63	22	20	40	55	11	17	6			
APX40R08007-25.4	80	25.4	26	50	70	13	20	7			
APX40R10008-31.75	100	31.75	32	63	80	17	26	8			

Unit: mm

HX640WR 殼型七角形平面銑刀
SHELL TYPE HEPTAGON FACE MILLING CUTTER

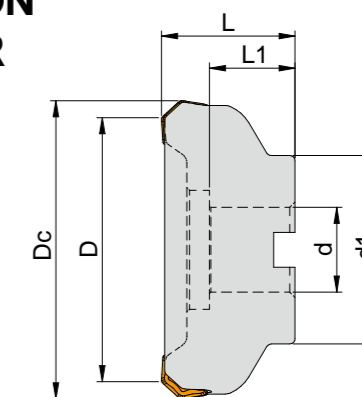
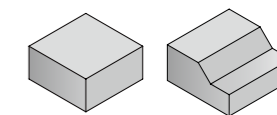

規格表 Specification

型號 Model	D	Dc	d	d1	L1	L	T	刀片類型 Inserts	螺絲 Screw	板手 Wrench
HX640WR08008-25.4	80	93	25.4	56	26	50	8	NNMU200608	TS6022	T15
HX640WR08010-25.4	80	93	25.4	56	26	50	10			
HX640WR10010-31.75	100	113	31.75	70	32	50	10			
HX640WR10014-31.75	100	113	31.75	70	32	50	14			

Unit: mm

HX640SR 殼型七角形平面銑刀
SHELL TYPE HEPTAGON FACE MILLING CUTTER

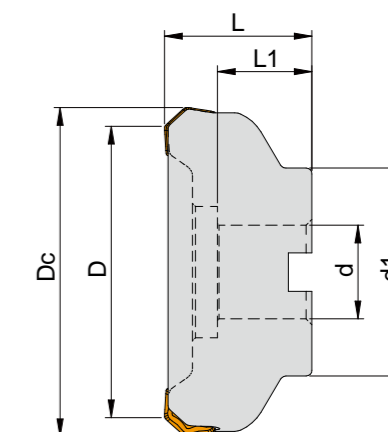
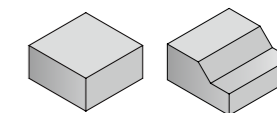

規格表 Specification

型號 Model	D	Dc	d	d1	L1	L	T	刀片類型 Inserts	螺絲 Screw	板手 Wrench
HX640SR10005-31.75	100	113	31.75	70	32	50	5	NNMU200708	TS5009	T20

Unit: mm

DSX445

**殼型平面銑刀
SHELL TYPE FACE
MILLING CUTTER**

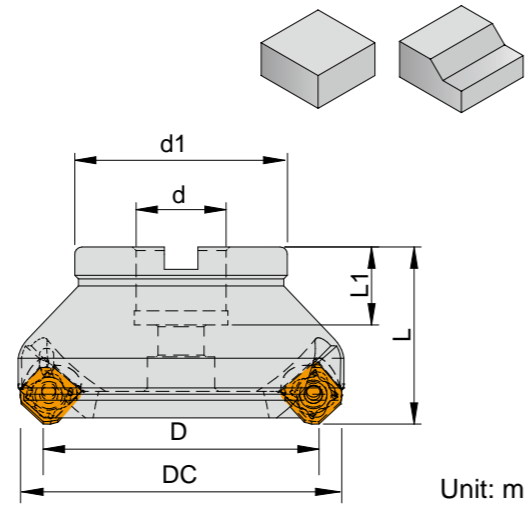

規格表 Specification

型號 Model	D	DC	d	d1	L1	L	T	刀片類型 Inserts	螺絲 Screw	板手 Wrench
DSX445R04004-16	40	53	16	35	18	40	4	SN..140812AN...	TS4026	T15
DSX445R05004-22	50		22	47	20		4			
DSX445R06305-22	63	76	22	50	20		5			
DSX445R06305-25.4			25.4				5			
DSX445R08006-27	80	93	27	60	22	50	6			
DSX445R08006-25.4			25.4				6			
DSX445R10007-32	100	113	32	70	32		7			
DSX445R10007-31.75			31.75				7			
DSX445R12508-40	125	138	40	80	36	63	8			
DSX445R12508-38.1			38.1				8			
DSX445R16010-40	160	173	40	100	38		10			
DSX445R16010-50.8			50.8				10			
DSX44R20012-47.625	200	213	47.625	175	36	63	12			
DSX445R25014-47.625	250	263	47.625	220	36	63	14			

Unit: mm

BXD15

**多功能端銑刀
MULTI-FUNCTION END MILL**

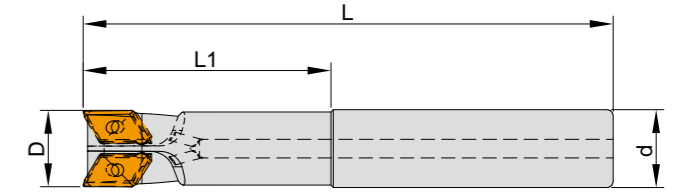
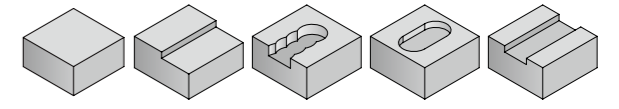

規格表 Specification

型號 Model	D	d	L1	L	T	刀片類型 Inserts	螺絲 Screw	板手 Wrench
BXD15-252-170	25	25	80	170	2	XDGT1550PDER-G04	TS4002	T15
BXD15-322-230	22	32	50	230	2			
BXD15-322-260	32	32	60	260	2			

Unit: mm

BXD15

**殼型多功能銑刀
SHELL TYPE MULTI-FUNCTION
MILLING CUTTER**

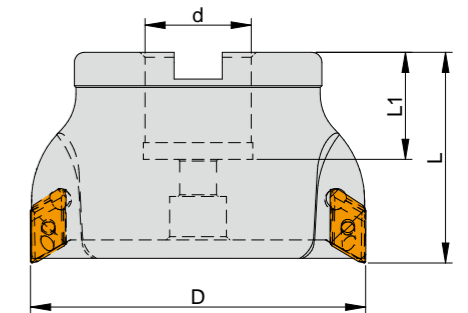
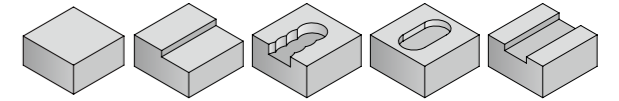

規格表 Specification

型號 Model	D	d	L1	L	T	刀片類型 Inserts	螺絲 Screw	板手 Wrench
BXD15-05004R-22	50	22	22.5	50	4	XDGT1550PDER-G04	TS4023	T15
BXD15-06305R-22	63	22	22.5	50	5			
BXD15-08006R-27	80	27	23	55	6			
BXD15-10006R-31.75	100	31.75	32	63	6			

Unit: mm

FR 圓刃端銑刀
ROUND INSERT END MILL

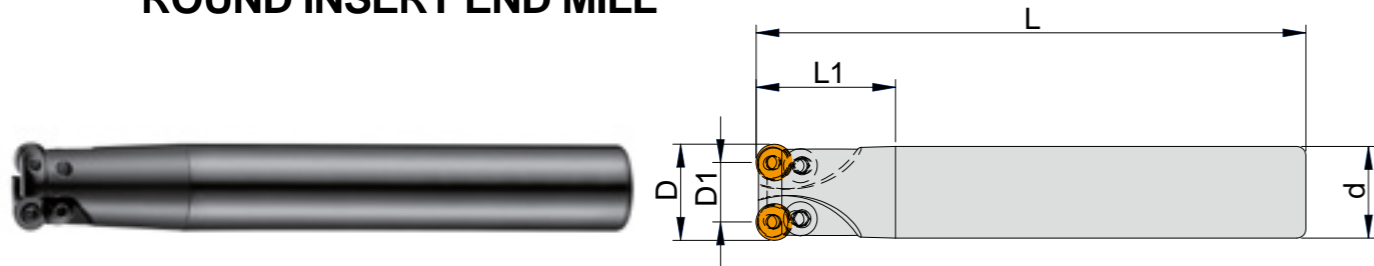
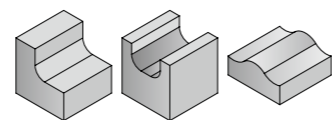

規格表 Specification		Unit: mm									
型號 Model	D	D1	d	L2	L	T	螺絲 Screw	刀片類型 Inserts	扳手 Wrench	壓板 Ciamp	
C25-FR-5R25-150	25	15	25	50	150	2	TS4004	RPMW1003	T15	M5X0.8 M5傘型 AS5	
C25-FR-5R25-180	25	15			180	2					
C25-FR-5R25-250	25	15			250	2					
C25-FR-5R26-150	26	16	30	150	2						
C25-FR-5R30-150	25	20		150	3						
C25-FR-5R30-200	30	20		200	3						
C25-FR-5R30-300	30	20	35	300	3						
C32-FR-5R32-150	32	22		55	150	3	TS4004				
C32-FR-5R32-200	32	22			200	3					
C32-FR-5R35-150	35	25	150		3						
C32-FR-5R35-200	35	25	200		3						
C32-FR-5R35-250	35	25	250		3						
C32-FR-5R35-300	35	25	300		3						
C32-FR-5R35-350	35	25	350		3						
C32-FR-5R40-180	40	30	45	180	3	TS4004	RPMW1203				T20
C32-FR-5R40-250	40	30		250	3						

WEM 直角銑刀
ORTHOGONAL MILLING CUTTER

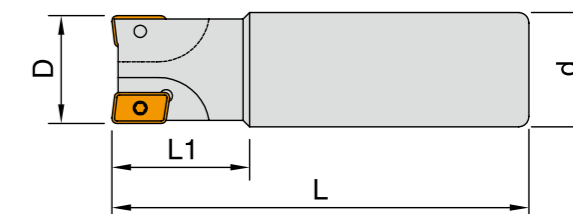
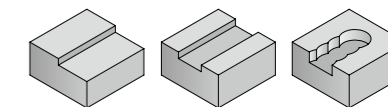

規格表 Specification		Unit: mm									
型號 Model	D	d	L1	L	T	刀片類型 Inserts	螺絲 Screw	扳手 Wrench			
WEM20R101S12	10	12	20	100	1	APMT1035..PDER-H APET1035..PDER-S	TS2515	T08			
WEM20R121S12	12	12	25	100	1						
WEM20R162S16	16	16	25	120	2						
WEM20R203S20	20	20	30	120	3						
WEM20R254S25	25	25	35	150	4						
WEM20R325S32	32	32	45	150	5		TS2515				
WEM20R406S32	40	32	45	135	6						
WEM20R506S32	50	32	45	135	6						
WEM20R636S32	63	32	45	135	6						
WEM30R252S25	25	25	40	150	2				APMT1605..PDER-H APET1605..PDER-S	TS4004	T15
WEM30R252S25L	25	25	40	220	2						
WEM30R322S32	32	32	45	150	2						
WEM30R322S32L	32	32	45	250	2						
WEM30R323S32	32	32	45	150	3						
WEM30R353S32	35	32	45	150	3						
WEM30R353S32L	35	32	45	250	3						
WEM30R403S32	40	32	45	135	3						
WEM30R504S32	50	32	45	135	4						

WEM 直角殼型面銑刀
SHELL TYPE ORTHOGONAL FACE
MILLING CUTTER

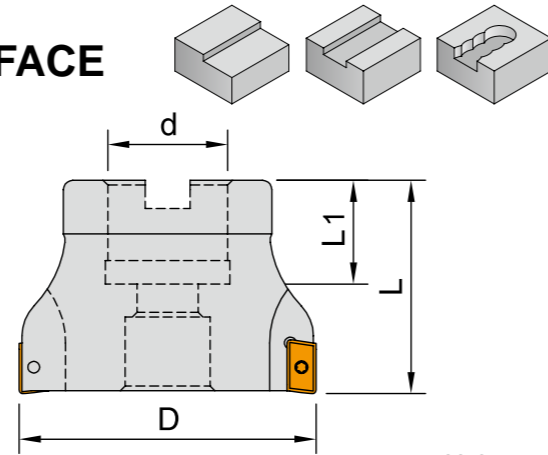

規格表 Specification

型號 Model	D	d	L1	L	T	刀片類型 Inserts	螺絲 Screw	板手 Wrench
WEM20R05006-22	50	22	20	45	6	APMT1035..PDER-H APET1035..PDER-S	TS2515	T08
WEM20R05006-25.4	50	25.4	20	45	6			
WEM20R06306-22	63	22	20	45	6			
WEM20R06306-25.4	63	25.4	20	45	6			
WEM30R05004-22	50	22	20	45	4	APMT1605..PDER-H APET1605..PDER-S	TS4004	T15
WEM30R05004-25.4	50	25.4	20	45	4			
WEM30R06305-22	63	22	20	45	5			
WEM30R06305-25.4	63	25.4	20	45	5			
WEM30R08006-25.4	80	25.4	26	50	6			
WEM30R08006-27	80	27	26	50	6			
WEM30R10008-31.75	100	31.75	32	55	8			
WEM30R12510-38.1	125	38.1	38	63	10			
WEM30R16012-50.8	160	50.8	38	63	12			

Unit: mm

WEXR 直角端銑刀
ORTHOGONAL END
MILLING CUTTER

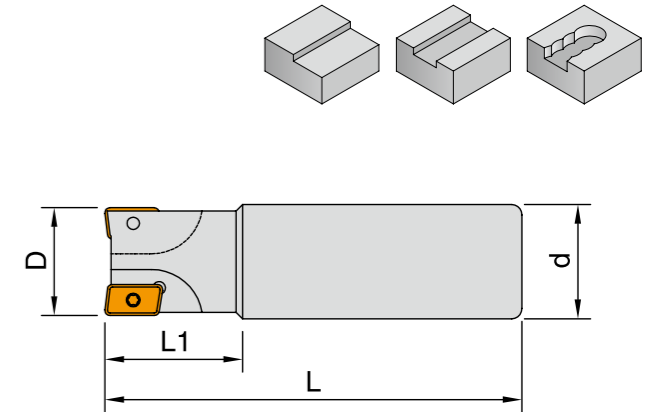

規格表 Specification

總類	型號 Model	D	L	L1	d	T	刀片類型 Inserts	螺絲 Screw	板手 Wrench			
STANDARD 標準	WEXR 2016S-2	16	120	35	16	2	AXMT1235 AXET1235	TS3014	T08			
	WEXR 2017S-2	17										
	WEXR 2018S-2	18										
	WEXR 2019S-2	19										
	WEXR 2020S-3	20	120	40	20	3						
	WEXR 2021S-3	21										
	WEXR 2022S-3	22										
	WEXR 2023S-3	23										
	WEXR 2024S-3	24										
	WEXR 2025S-3	25										
	WEXR 2026S-3	26										
	WEXR 2025S-4	25								150	45	25
	WEXR 2028S-4	26										
	WEXR 2027S-4	27										
	WEXR 2028S-4	28										
	WEXR 2029S-4	29	175	50	16	2						
	WEXR 2030S-4	30										
	WEXR 2031S-4	31										
	WEXR 2032S-5	32								185	60	20
	WEXR 2033S-4	33										
WEXR 2034S-4	34											
WEXR 2035S-4	35	200					70	25	3			
WEXR 2016L-2	16											
WEXR 2017L-2	17											
WEXR 2020L-2	20											
WEXR 2021L-2	21											
WEXR 2025L-3	25		200	45	70	4						
WEXR 2026L-3	26											
WEXR 2025L-4	25		250	80	32							
WEXR 2026L-4	26											
WEXR 2032L-4	32											
WEXR 2033L-4	33	200	50	25								
WEXR 2026L-4	26											
WEXR 2032L-4	32	250	50	32								
WEXR 2033L-4	33											
WEXR 2035L-4	35											

Unit: mm

WEXR

直角端銑刀

ORTHOGONAL MILLING CUTTER

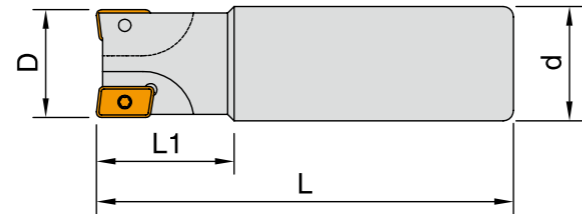
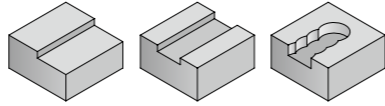

規格表 Specification

Unit: mm

總類	型號 Model	D	L	L1	d	T	刀片類型 Inserts	螺絲 Screw	板手 Wrench
STANDARD 標準	WEXR 3025S-2	25	150	40	25	2	AXMT1705 AXET1705	TS4023	T15
	WEXR 3026S-2	26							
	WEXR 3027S-2	27							
	WEXR 3028S-2	28							
	WEXR 3029S-2	29							
	WEXR 3030S-2	30							
	WEXR 3031S-2	31							
	WEXR 3032S-3	32							
	WEXR 3033S-3	33							
	WEXR 3034S-3	34							
	WEXR 3035S-3	35							
	WEXR 3036S-3	36							
	WEXR 3040S-4	40							
	WEXR 3025L-2	25							
	WEXR 3026L-2	26							
	WEXR 3027L-2	27							
WEXR 3028L-2	28								
WEXR 3029L-2	29								
WEXR 3030L-2	30								
WEXR 3031L-2	31								
WEXR 3032L-2	32								
WEXR 3033L-2	33								
WEXR 3034L-2	34								
WEXR 3035L-2	35								
WEXR 3036L-2	36								
WEXR 3040L-4	40								

WEXR

殼型端銑刀

SHELL TYPE ORTHOGONAL MILLING CUTTER

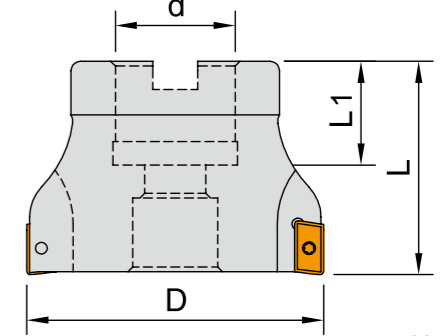
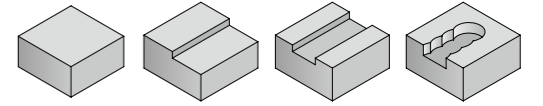

規格表 Specification

Unit: mm

型號 Model	D	L	L1	d	T	刀片類型 Inserts	螺絲 Screw	板手 Wrench			
WEXR20050-22-6T	50	45	20	22	6	AXMT1235... AXET1235...	TS3014	T08			
WEXR20063-22-7T	63			22	7						
WEXR20063-25.4-7T				25.4							
WEXR20080-27-8T	80	50	26	27	8						
WEXR20080-25.4-8T				25.4							
WEXR20100-32-10T	100			32	10						
WEXR20100-31.75-10T			31.75								
WEXR30050-22-4T	50	45	20	22	4				AXMT1705... AXET1705...	TS4023	T15
WEXR30063-22-5T	63			22	5						
WEXR30063-25.4-5T				25.4							
WEXR30080-25.4-6T	80	50	26	25.4	6						
WEXR30080-27-7T				27							
WEXR30100-32-7T	100			32	7						
WEXR30100-31.75-7T			31.75								
WEXR30125-40-8T	125	63	38	40	8						
WEXR30125-38.1-8T				38.1							
WEXR30160-40-10T	160			40	10						
WEXR30160-50.8-10T			50.8								

WEM BT 整體式銑刀
BT MILLING CUTTER HOLDER

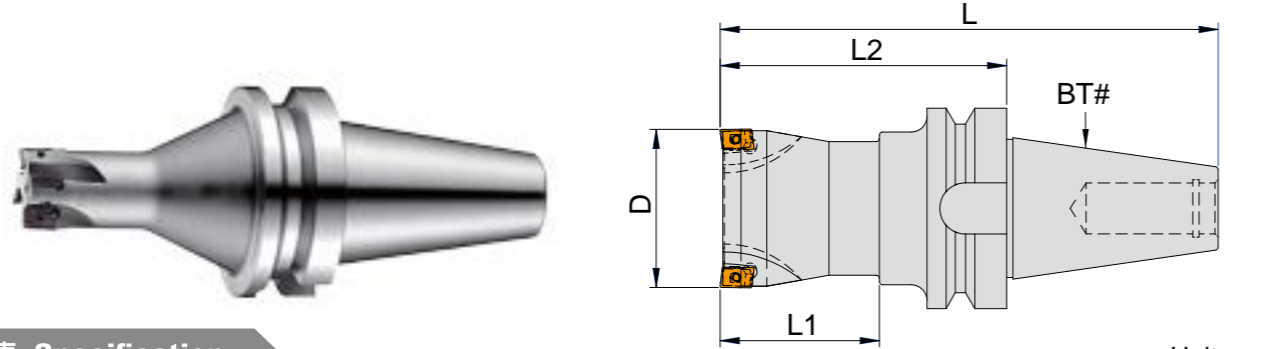

規格表 Specification

型號 Model	D	L2	L1	L	T	刀片類型 Inserts	螺絲 Screw	扳手 Wrench
BT30-WEM20R162-80	16	32	80	129	2	APMT1035..PDER-H APET1035..PDER-S	TS2515	T08
BT30-WEM20R203-80	20	35			3			
BT30-WEM20R254-80	25	45			4			
BT40-WEM20R162-90	16	32	90	156	2			
BT40-WEM20R203-90	20	35			3			
BT40-WEM20R254-90	25	40			4			
BT40-WEM20R325-90	32	40			5			
BT40-WEM20R406-90	40	50			6			
BT40-WEM20R506-90	50	55			6			
BT40-WEM20R636-90	63	55			6			
BT40-WEM20R638-90	63	55			8			

Unit: mm

WEXR BT 整體式銑刀
BT MILLING CUTTER HOLDER

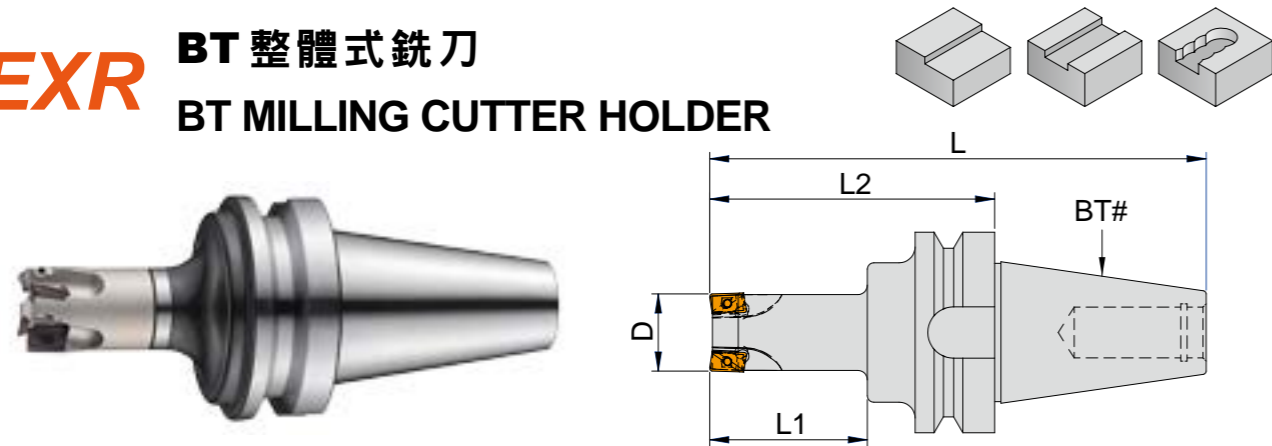

規格表 Specification

型號 Model	D	L2	L1	L	T	刀片類型 Inserts	螺絲 Screw	扳手 Wrench
BT30-WEX20R203-80	20	35	80	129	3	AXMT1235..PEER-..	TS3014	T08
BT30-WEX20R253-80	25	45	80	129	3			
BT40-WEX20R203-90	20	35	90	156	3			
BT40-WEX20R253-90	25	40	90	156	3			

Unit: mm

2280 八角重切銑刀
OCTAGON HEAVY DUTY MILLING CUTTER

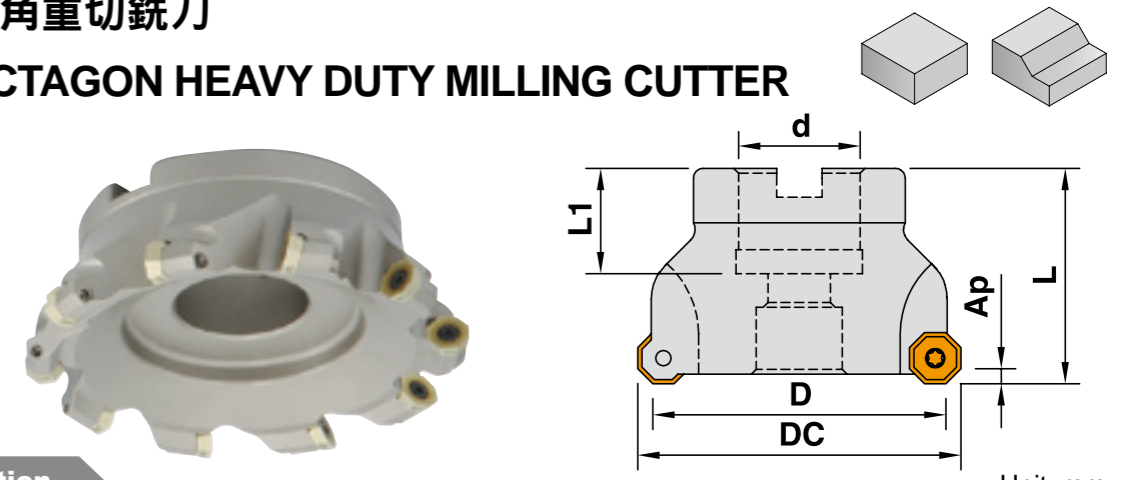

規格表 Specification

型號 Model	D	Dc	d1	L	L1	AP	T	刀片類型 Inserts	螺絲 Screw	扳手 Wrench
2280.B.050.Z04.03-22	50	58	22	45	21	3	4	ODMT0504	TS4023	T15
2280.B.050.Z04.03-25.4	50	58	25.4	45	21	3	4			
2280.B.063.Z05.03-22	63	71	22	45	21	3	5			
2280.B.063.Z05.03-25.4	63	71	25.4	45	21	3	5			
2280.B.080.Z06.03-27	80	88	27	50	23	3	6			
2280.B.080.Z06.03-25.4	80	88	25.4	50	21	3	6			
2280.B.100.Z07.03-32	100	108	32	50	26	3	7			
2280.B.100.Z07.03-31.75	100	108	31.75	50	26	3	7			
2280.B.125.Z08.03-40	125	133	40	55	32	3	8			
2280.B.125.Z08.03-38.1	125	133	38.1	55	32	3	8			
2280.B.160.Z10.03-40	160	168	40	63	32	3	10			
2280.B.160.Z10.03-50.8	160	168	50.8	63	38	3	10			
2280.B.200.Z12.03-60	200	208	60	63	36	3	12	ODMT0605	TS5009	T20
2280.B.200.Z12.03-47.625	200	208	47.625	63	36	3	12			
2280.B.260.Z12.03-47.625	260	268	47.625	63	36	3	12			
2280.B.063.Z04.04-22	63	73	22	45	21	4	4			
2280.B.063.Z04.04-25.4	63	73	25.4	45	21	4	4			
2280.B.080.Z05.04-27	80	90	27	50	23	4	5			
2280.B.080.Z05.04-25.4	80	90	25.4	50	21	4	5			
2280.B.100.Z06.04-32	100	110	32	50	26	4	6			
2280.B.100.Z06.04-31.75	100	110	31.75	50	26	4	6			
2280.B.125.Z08.04-40	125	135	40	55	32	4	8			
2280.B.125.Z08.04-38.1	125	135	38.1	55	32	4	8			
2280.B.160.Z10.04-40	160	170	40	63	38	4	10			
2280.B.160.Z10.04-50.8	160	170	50.8	63	38	4	10			
2280.B.200.Z12.04-60	200	210	60	63	38	4	12			
2280.B.210.Z12.04-47.625	210	220	47.625	63	38	4	12			
2280.B.260.Z12.04-47.625	260	270	47.625	63	38	4	12			

Unit: mm

4033 45°殼型面銑刀
45° SHELL TYPE FACE MILLING CUTTER

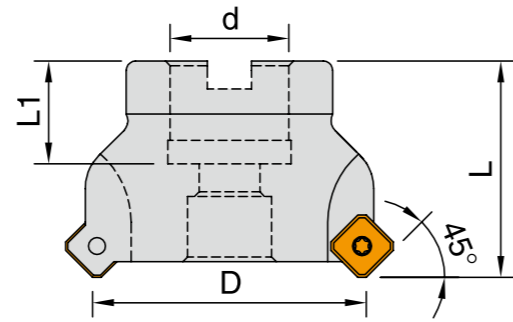
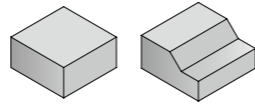

Unit: mm

規格表 Specification

型號 Model	D	d	L	L1	T	刀片類型 Inserts	螺絲 Screw	板手 Wrench
4033.B.050.Z04.06-22	50	22	40	20	4	SN.X1205..	TS4015	T15
4033.B.063.Z05.06-22	63	22			5			
4033.B.063.Z05.06-25.4	63	25.4	5					
4033.B.080.Z06.06-27	80	27	50	26	6			
4033.B.080.Z06.06-25.4	80	25.4			6			
4033.B.100.Z08.06-32	100	32			8			
4033.B.100.Z08.06-31.75	100	31.75	63	38	8			
4033.B.125.Z10.06-40	125	40			10			
4033.B.125.Z10.06-40-L	125	40			10			
4033.B.125.Z10.06-38.1	125	38.1			10			
4033.B.160.Z12.06-40	160	40	63	38	12			
4033.B.160.Z12.06-50.8	160	50.8			12			
4033.B.200.Z14.06-60	200	60			14			
4033.B.200.Z14.06-47.625	200	47.625			14			

4048 88°殼型銑刀
88° SHELL TYPE MILLING CUTTER

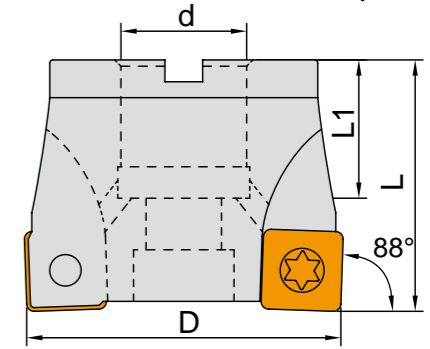
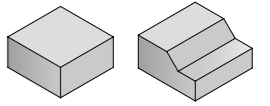

Unit: mm

規格表 Specification

型號 Model	D	d	L	L1	T	刀片類型 Inserts	螺絲 Screw	板手 Wrench
4048.B.050.Z04.06-22	50	22	40	21	4	SN.X1205..	TS4015	T15
4048.B.063.Z05.06-22	63	22	40		5			
4048.B.063.Z05.06-25.4	63	25.4	40		5			
4048.B.080.Z06.06-27	80	27	50	25	6			
4048.B.080.Z06.06-25.4	80	25.4	50		6			
4048.B.100.Z06.06-31.75	100	32	50		6			
4048.B.100.Z11.06-31.75	100	31.75	50	38	11			
4048.B.125.Z10.06-40	125	40	63		11			
4048.B.125.Z10.06-38.1	125	38.1	63		10			
4048.B.160.Z12.06-40	160	40	63		12			
4048.B.160.Z12.06-50.8	160	50.8	63	63	12			
4048.B.200.Z14.06-60	200	60	63		14			
4048.B.200.Z14.06-47.625	200	47.625	63		14			

SWES 鎖牙式高速重切削球刀
 THREADED HIGH SPEED HEAVY
 CUTTING BALL NOSE MILLING CUTTER

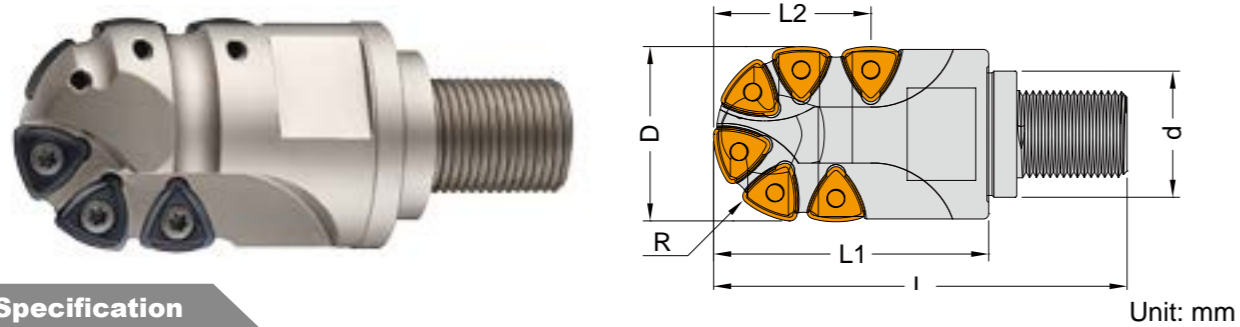
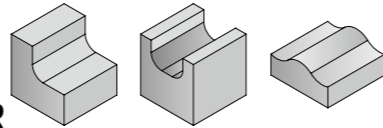

規格表 Specification

型號 Model	D	d	L2	L1	L	R	刀片類型 Inserts	螺絲 Screw	板手 Wrench
SWES2020-M10	20	18	20	33	52	10	P2633.-R10	TS2515	T08
SWES2521-M12	25	23	21	42	64	12.5	P2633.-R14	TS4023	T15
SWES3023-M12	30	23	23	50	72	15			
SWES3223-M16	32	23	23	50	72	16			
SWES4038-M18	40	26	38	65	101	20	P2633.-R25	TS5007	T20
SWES5045-M25	50	36	45	80	119	25			

Unit: mm

2330 高速重切削球刀
 HIGH SPEED HEAVY
 CUTTING BALL NOSE MILLING CUTTER

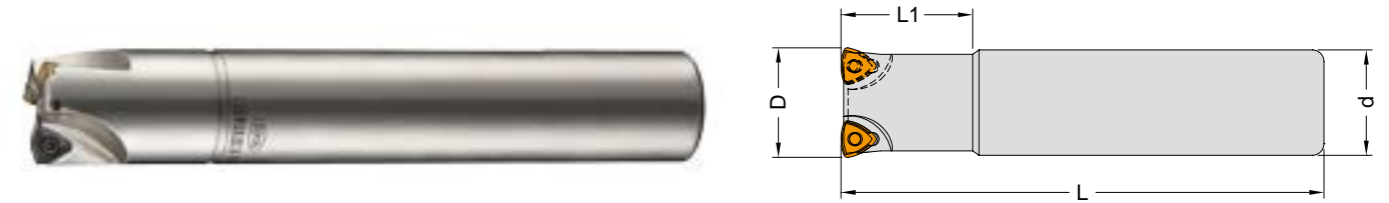
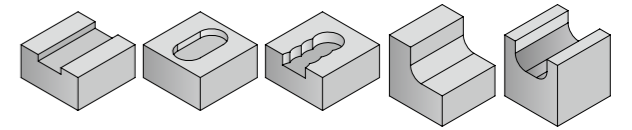

規格表 Specification

型號 Model	D	d	L1	L	T	刀片類型 Inserts	螺絲 Screw	板手 Wrench
2330R202-S20-150L	20	20	28	150	2	P2633.-R10	TS2507	T08
2330R212-S20-150L	21	20	28	150	2			
2330R253-S25-180L	25	25	72	180	3			
2330R263-S25-150L	26	25	28	150	3	P2633.-R14	TS4005	T15
2330R323-S32-150L	32	32	28	150	3			
2330R353-S32-180L	35	32	40	180	3			
2330R353-S32-230L	35	32	40	230	3			
2330R404-S32-200L	40	32	40	200	4	P2633.-R25	TS5002	T20
2330R402-S32-200L	40	32	45	200	2			
2330R503-S32-200L	50	32	45	200	3			

Unit: mm

2330 殼型高速重切削球刀
 SHELL TYPE HIGH SPEED
 HEAVY CUTTING BALL NOSE MILLING CUTTER

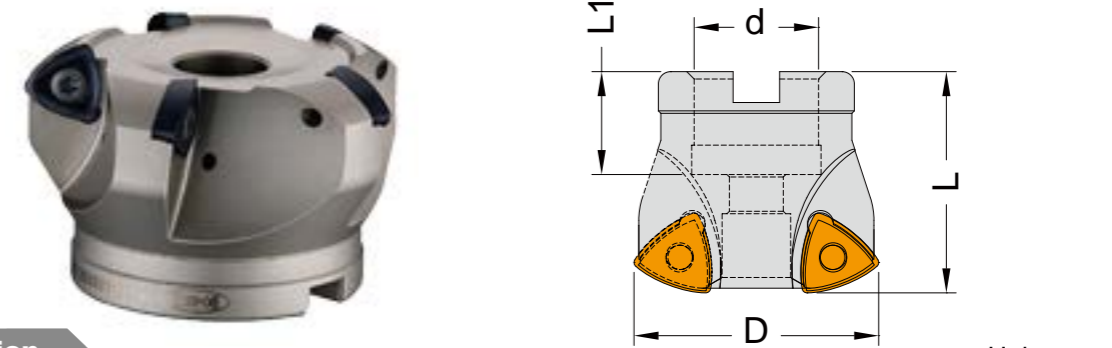
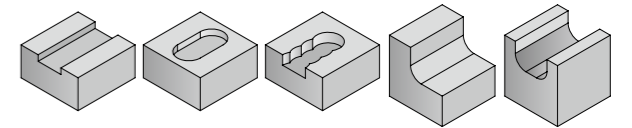

規格表 Specification

型號 Model	D	d	L1	L2	T	刀片類型 Inserts	螺絲 Screw	板手 Wrench
2330-05003R-22	50	22	50	21	3	P2633.-R25	TS5002	T20
2330-06304R-22	63	22	50	21	4			
2330-08005R-27	80	27	50	23	5			
2330-10006R-32	100	32	50	26	6			
2330-12507R-40	125	40	63	38	7			
2330-16008R-40	160	40	63	38	8			

Unit: mm

4041 直角銑刀
ORTHOGONAL MILLING CUTTER

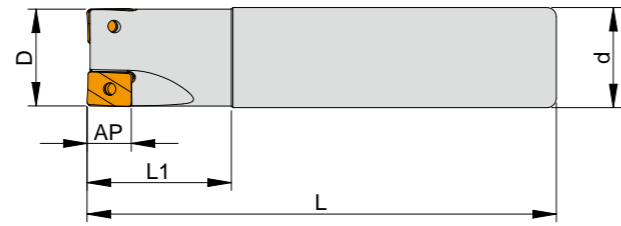
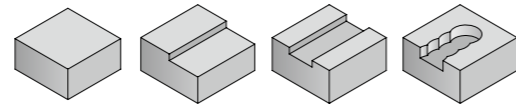

規格表 Specification

型號 Model	D	d	AP	L1	L	T	刀片類型 Inserts	螺絲 Screw	板手 Wrench
4041.W.032.Z02.13-150L	32	32	13	90	150	2	LNGX130708	TS4009	T15
4041.W.040.Z03.13-150L	40	32	13	45	150	3			

4041 直角殼型銑刀
SHELL TYPE ORTHOGONAL FACE MILLING CUTTER

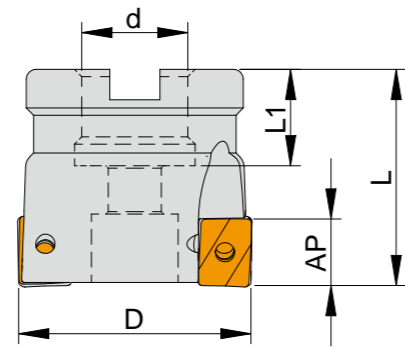
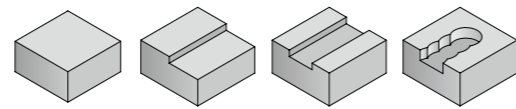

規格表 Specification

型號 Model	D	d	AP	L1	L	T	刀片類型 Inserts	螺絲 Screw	板手 Wrench
4041.B.050.Z04.13-22	50	22	13	22	45	4	LNGX130708	TS4009	T15
4041.B.063.Z04.13-22	63	22	13	22	45	4			
4041.B.063.Z06.13-22	63	22	13	22	45	6			
4041.B.063.Z06.13-25.4	63	25.4	13	25.4	45	6			
4041.B.080.Z07.13-25.4	80	25.4	13	25.4	50	7			

4042 直角銑刀
ORTHOGONAL MILLING CUTTER

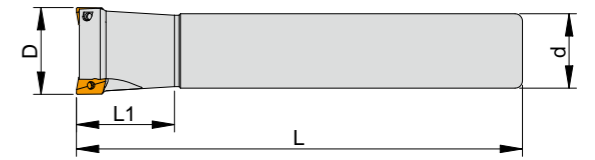
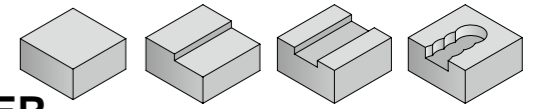

規格表 Specification

型號 Model	D	d	L1	L2	L	T	刀片類型 Inserts	螺絲 Screw	板手 Wrench
4042.W.012.Z01.08-130	12	12	30	100	130	1	ADMT080308R	TS2515	T08
4042.W.016.Z02.08-120	16	16	40	80	120	2			
4042.W.016.Z02.08-150	16	16	40	110	150	2			
4042.W.016.Z02.08-200	16	16	30	170	200	2			
4042.W.020.Z03.08-150	20	20	40	100	150	3			
4042.W.021.Z03.08-150	21	20	35	115	150	3			
4042.W.025.Z04.08-150	25	20	40	110	150	4	ADMT120408R	TS3006	T10
4042.W.030.Z04.08-150	30	25	35	115	150	4			
4042.W.025.Z03.12-150	25	32	35	115	150	3			
4042.W.025.Z03.12-200	25	32	40	160	200	3			
4042.W.026.Z03.12-200	26	32	35	115	200	3			
4042.W.032.Z04.12-130	32	32	40	90	130	4			
4042.W.032.Z04.12-190	32	32	40	150	190	4			
4042.W.040.Z05.12-200	40	32	40	160	200	5			

4042 直角殼型銑刀
SHELL TYPE ORTHOGONAL MILLING CUTTER

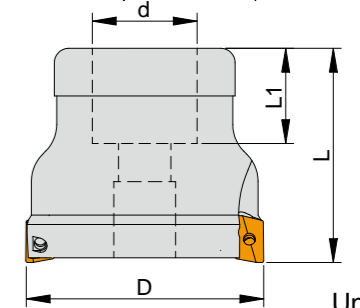
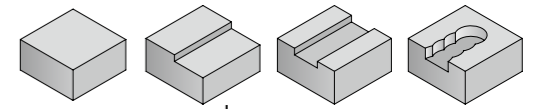

規格表 Specification

型號 Model	D	d	L1	L	T	刀片類型 Inserts	螺絲 Screw	板手 Wrench
4042.B.050.Z06.12-22	50	22	20	45	6	ADMT120408R	TS3006	T10
4042.B.063.Z05.12-22	63	22	22	50	5			
4042.B.063.Z07.12-25.4	63	25.4	22	50	7			
4042.B.040.Z04.16-16	40	16	18	40	4	ADMT160608R	TS4023	T15
4042.B.050.Z05.16-22	50	22	20	45	5			
4042.B.063.Z06.16-22	63	22	22	50	6			
4042.B.063.Z06.16-25.4	63	25.4	22	50	6			
4042.B.125.Z10.16-40	125	40	32	63	10			

2038 殼型粗銑刀
SHELL TYPE ROUGH MILLING CUTTER

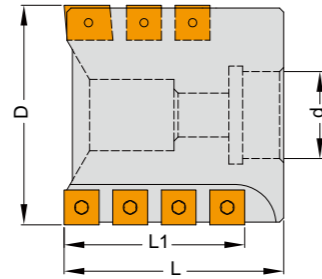
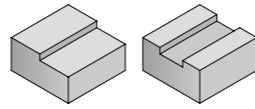

規格表 Specification

型號 Model	D	d	L1	L	T	刀片類型 Inserts	螺絲 Screw	扳手 Wrench
2038-063-67-25.4-4T	63	25.4	67	80	4	LPMT150408(2)	TS5004	T20
2038-063-67-27-4T	63	27	67	80	4	SPLT120408(12)		
2038-080-67-31.75-6T	80	31.75	67	80	6	LPMT150408(3)		
2038-080-67-32-6T	80	32	67	80	6	SPLT120408(18)		
2038-100-77-38.1-8T	100	38.1	77	100	8	LPMT150408(4)		
2038-100-77-40-8T	100	40	77	100	8	SPLT120408(28)		
2038-160-80-50-6T	160	50	88	109	10	LPMT150408(5) SPLT120408(40)		

Unit: mm

SGP 88° 殼型銑刀
88° SHELL TYPE MILLING CUTTER

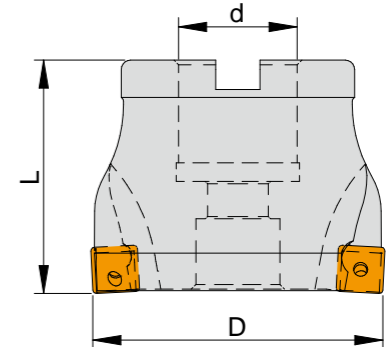
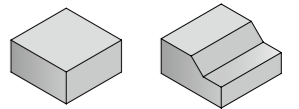

規格表 Specification

型號 Model	D	d	L	T	刀片類型 Inserts	螺絲 Screw	扳手 Wrench
SGP-050-22-04T	50	22	50	4	SPMT120408	TS5002	T20
SGP-063-22-05T	63	22	50	5			
SGP-063-25.4-05T	63	25.4	50	5			
SGP-080-27-06T	80	27	55	6			
SGP-080-25.4-06T	80	25.4	55	6			
SGP-100-32-08T	100	32	55	8			
SGP-100-31.75-08T	100	31.75	55	8			
SGP-125-40-8T	125	40	63	8			
SGP-160-40-10T	160	40	63	10			
SGP-160-50.8-10T	160	50.8	63	10			

Unit: mm

MRO 圓刃銑刀 ROUND INSERT MILLING CUTTER

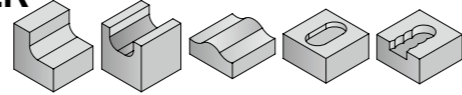
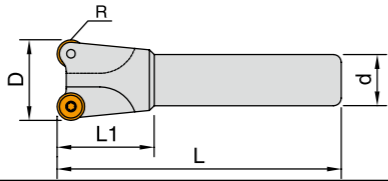

Unit: mm

型號 Model	D	d	L	L1	R	T	刀片類型 Inserts	螺絲 Screw	板手 Wrench
MRO0816R-2-130	16	20	130	40	4	2	RO..0803MO..	TS3002	T10
MRO0816R-2-180	16	20	180	40		2			
MRO0820R-3-150	20	20	150	40		3			
MRO0820R-3-200	20	20	200	45		3			
MRO1025R-2-150	25	25	150	45	5	2	RO..10T3MO..	TS4005	T10
MRO1025R-2-250	25	25	250	70		2			
MRO1030R-2-150	30	25	150	45		2			
MRO1030R-2-250	30	25	250	40		2			
MRO1032R-3-150	32	32	150	45	6	3	RO..1204MO..	TS4007	T15
MRO1032R-3-250	32	32	250	70		3			
MRO1232R-2-150	32	32	150	50		2			
MRO1232R-2-250	32	32	250	70		2			
MRO1240R-3-170	40	32	170	45	6	3	RO..1204MO..	TS4007	T15
MRO1240R-3-220	40	32	220	45		3			

MRO 殼型圓刃面銑刀 SHELL TYPE ROUND INSERT MILLING CUTTER

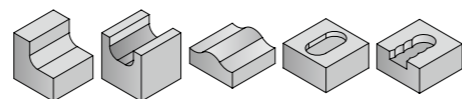
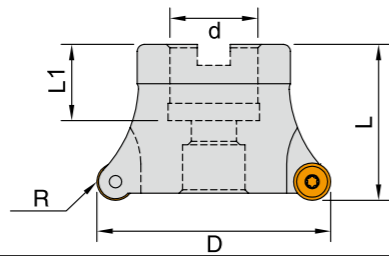

Unit: mm

型號 Model	D	d	L	L1	R	T	刀片類型 Inserts	螺絲 Screw	板手 Wrench
MRO08040-16-5T	40	16	40	18	4	5	RO..0803MO..	TS3002	T10
MRO08050-22-6T	50	22	45	22		6			
MRO10050-22-5T	50	22	45	22	5	5	RO..10T3MO..	TS4005	T15
MRO10063-22-6T	63	22				6			
MRO12050-22-4T	50	22	45	22	6	4	RO..1204MO..	TS4007	T15
MRO12050-22-5T	50	22				5			
MRO12063-22-5T	63	22				5			
MRO12063-22-6T	63	22				6			
MRO12080-27-7T	80	27	50	26	8	7	RO..1605MO..	TS5002	T20
MRO12100-32-8T	100	32				32			
MRO16063-22-4T	63	22	45	22	8	4	RO..1605MO..	TS5002	T20
MRO16063-22-5T	63	22				5			
MRO16080-27-6T	80	27	50	26	8	6	RO..1605MO..	TS5002	T20
MRO16100-32-7T	100	32				32			
MRO16125-40-8T	125	40	55	36	8				

**MRO 鎖牙式圓刃銑刀
THREADED ROUND INSERT
MILLING CUTTER**

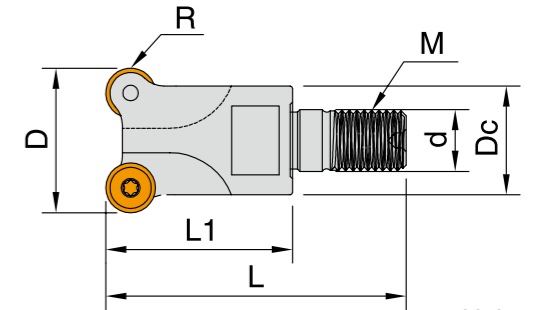
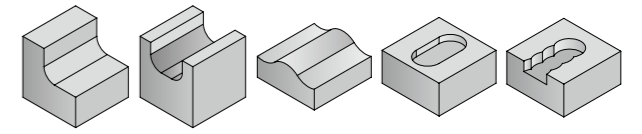

Unit: mm

規格表 Specification

型號 Model	D	Dc	d	L	L1	M	T	R	刀片類型 Inserts	螺絲 Screw	板手 Wrench
MRO0816R-M08-2	16	15	8.5	43	26	M08	2	4	RO..0803MO..	TS3002	T10
MRO0820R-M10-2	20	18	10.5	50	32	M10	2				
MRO0820R-M10-3	20						3				
MRO0825R-M12-3	25						3				
MRO0830R-M12-4	30	23	12.5	60	38	M12	4	5	RO..10T3MO..	TS4005	T15
MRO1025R-M12-2	25						2				
MRO1025R-M12-3	25						3				
MRO1026R-M12-3	26						3				
MRO1030R-M12-3	30	29	17	63	41	M16	3	6	RO..1204MO..	TS4007	T15
MRO1030R-M12-4	30						4				
MRO1032R-M16-4	32						4				
MRO1035R-M16-4	35						4				
MRO1035R-M16-5	35	66	43	66	43	M16	5	6	RO..1204MO..	TS4007	T15
MRO1042R-M16-5	42						5				
MRO1042R-M16-6	42	6									
MRO1232R-M16-2	32	66	43	66	43	M16	2	6	RO..1204MO..	TS4007	T15
MRO1240R-M16-3	40						3				

2239 粗球刀
BALL NOSE ROUGH END MILL

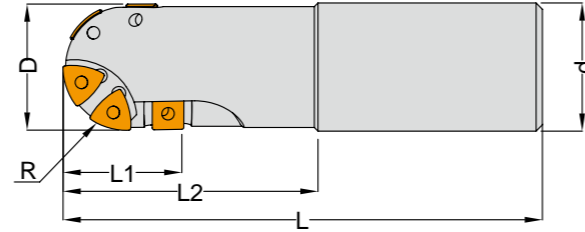
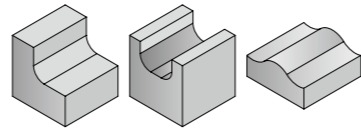

規格表 Specification

Unit: mm

型號 Model	D	d	L1	L2	L	R	刀片類型 Inserts	螺絲 Screw	板手 Wrench
2239R-2020-140	20	20	20	50	140	10	P2631.-R10 SP..0603..	TS2507	T08
2239R-2020-190	20	20	20	90	190	10			
2239R-2525-155	25	25	23	55	155	12.5	P2631.-R12 SP..0603..	TS2507	T08
2239R-2525-210	25	25	23	110	210	12.5			
2239R-3232-160	32	32	31	100	160	16	P2631.-R16 SP..09T3..	TS4007	T15
2239R-3232-220	32	32	31	100	220	16			
2239R-4042-170	40	42	41	100	170	20	P2631.-R20 SP..1204..	TS5011	T20
2239R-4042-250	40	42	41	100	250	20			
2239R-5050-190	50	50.8	46	100	190	25	P2631.-R25 SP..1204..	TS5011	T20
2239R-5050-280	50	50.8	46	100	280	25			

2139 精球刀
FINISHING BALL NOSE
MILLING CUTTER

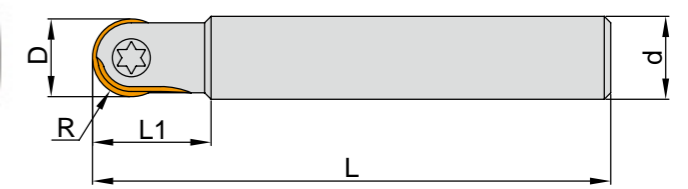
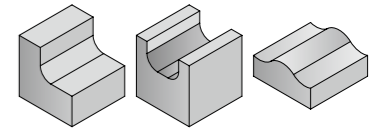

規格表 Specification

Unit: mm

	型號 Model	D	d	L1	L	R	刀片類型 Inserts	螺絲 Screw	板手 Wrench
STANDARD 標準型	2139R-0810-100	8	10	25	100	4	P3200B08	BR-4R	T08
	2139R-1010-130	10	10	30	130	5	P3200D10	BR-5R	T15
	2139R-1212-130	12	12	30	130	6	P3200D12	BR-6R	T20
	2139R-1616-150	16	16	36	150	8	P3200D16	BR-8R	T20
	2139R-2020-160	20	20	45	160	10	P3200D20	BR-10R	T20
	2139R-2525-180	25	25	45	180	12.5	P3200D25	BR-12R	T30
	2139R-3032-200	30	32	50	200	15	P3200D30	BR-15R	T30
	2139R-3232-200	32	32	50	200	16	P3200D32	BR-16R	T30
	2139R-0810-140	8	10	30	140	4	P3200B08	BR-4R	T08
EXTRA LONG 加長型	2139R-1012-150	10	12	25	150	5	P3200D10	BR-5R	T15
	2139R-1216-160	12	16	25	160	6	P3200D12	BR-6R	T20
	2139R-1620-200	16	20	30	200	8	P3200D16	BR-8R	T20
	2139R-2025-250	20	25	30	250	10	P3200D20	BR-10R	T20
	2139R-2532-250	25	32	35	250	12.5	P3200D25	BR-12R	T30
	2139R-3032-250	30	32	35	250	15	P3200D30	BR-15R	T30
	2139R-3242-280	32	42	45	280	16	P3200D32	BR-16R	T30

2139 鎖牙式精修球刀
THREADED FINISHING BALL NOSE MILLING CUTTER

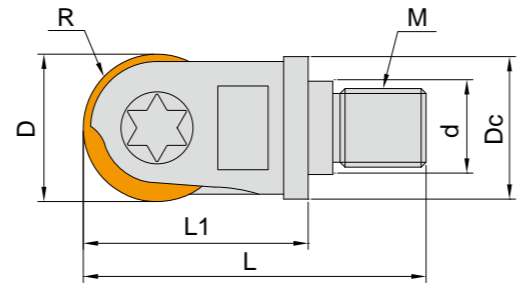
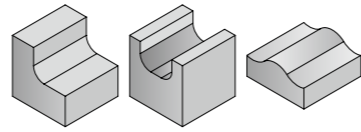

規格表 Specification

型號 Model	D	d	Dc	L1	L	M	R	刀片類型 Inserts	螺絲 Screw	板手 Wrench
2139R10-M05	10	5.5	9	21	33	M5	5	P3200D10	BR-5R	T15
2139R12-M06	12	6.5	11	42	38	M6	6	P3200D12	BR-6R	T20
2139R16-M08	16	8.5	15	26	45	M8	8	P3200D16	BR-8R	T20
2139R20-M10	20	10.5	18	35	53	M10	10	P3200D20	BR-10R	T20
2139R25-M12	25	12.5	23	41	63	M12	12.5	P3200D25	BR-12R	T30
2139R30-M12	30	12.5	25	41	63	M12	15	P3200D30	BR-15R	T30
2139R32-M16	32	17	29	42	65	M16	16	P3200D32	BR-16R	T30

Unit: mm

MWE 鎖牙式多功能銑刀
THREADED MULTI-FUNCTION MILLING CUTTER

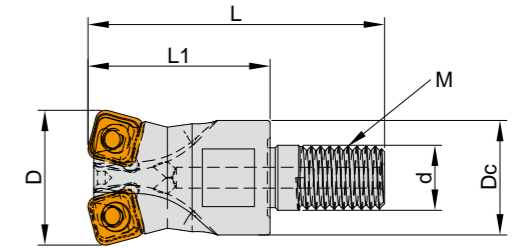
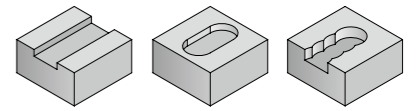

規格表 Specification

型號 Model	D	d	L1	L	T	刀片類型 Inserts	螺絲 Screw	板手 Wrench
MWE09-262-M12	26	13	35	57	2	SDMT09T320	TS3502	T15
MWE09-353-M16	35	17	40	63	3			

Unit: mm

MWE 殼型功能銑刀
SHELL TYPE MULTI-FUNCTION MILLING CUTTER

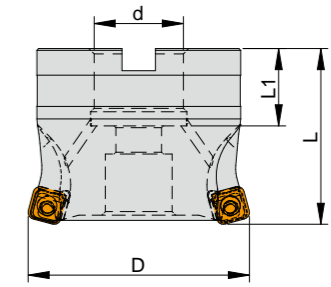
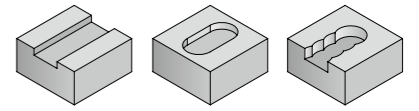

規格表 Specification

型號 Model	D	d	L1	L	T	刀片類型 Inserts	螺絲 Screw	板手 Wrench
MWE09-05005R-22	50	22	20	45	5	SDMT09T320	TS3510	T15
MWE09-06306R-25.4	63	25	22	50	6			

Unit: mm

MWE 多功能倒角刀
MULTI-FUNCTION CHAMFERING CUTTER

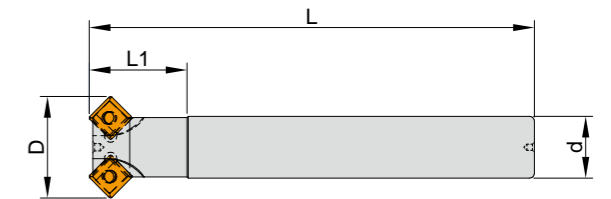
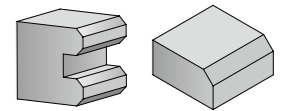

規格表 Specification

型號 Model	D	d	L1	L	T	刀片類型 Inserts	螺絲 Screw	板手 Wrench
MWE09-BC33-130-4T	33	22	30	130	4	SDMT09T320	TS3502	T15
MWE09-BC33-180-4T	33	22	80	180	4			

Unit: mm

MWC 端銑刀
HIGH SPEED FEED END
MILLING CUTTER

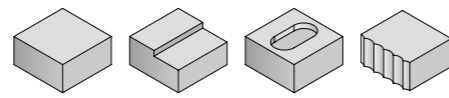
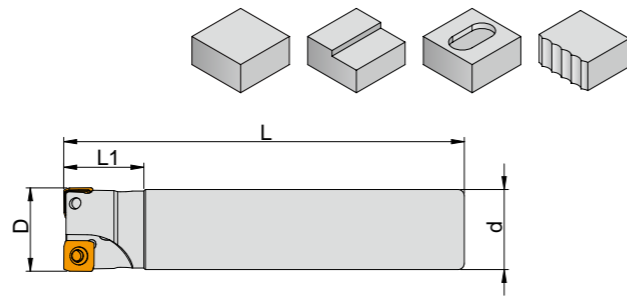

規格表 Specification

型號 Model	D	d	L2	L	T	刀片類型 Inserts	螺絲 Screw	板手 Wrench
MWC09-262-125	26	25	25	125	2	SDMT09T3..	TS3502	T15
MWC09-353-150	35	32	50	150	3			

Unit: mm

MWC 鎖牙式端銑刀
THREADED HIGH SPEED FEED
END MILLING CUTTER

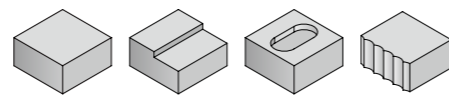
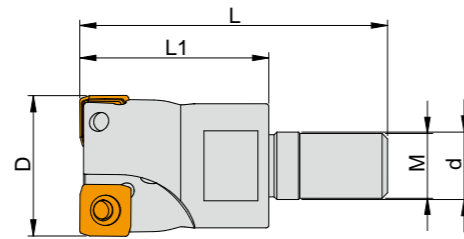

規格表 Specification

型號 Model	D	d	L2	L	T	刀片類型 Inserts	螺絲 Screw	板手 Wrench
MWC09-262-M12	26	12.5	35	57	2	SDMT09T3..	TS3502	T15
MWC09-353-M16	35	17	40	63	3			

Unit: mm

MWC 殼型銑刀
SHELL TYPE HIGH SPEED
FEED MILLING CUTTER

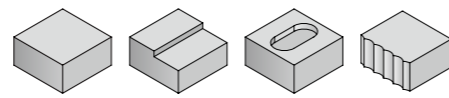
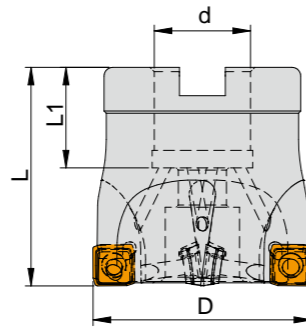

規格表 Specification

型號 Model	D	d	L1	L	T	刀片類型 Inserts	螺絲 Screw	板手 Wrench
MWC09-05004R-22	50	22	23	50	4	SDMT09T3..	TS3510	T15
MWC09-06307R-25.4	63	25.4	26	50	7			

Unit: mm

MRD 圓刃銑刀
ROUND INSERT
MILLING CUTTER

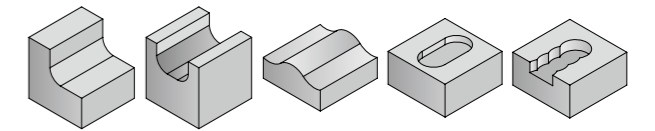
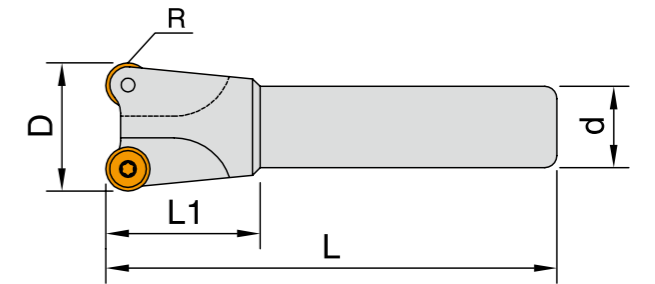

規格表 Specification

型號 Model	D	d	L	L1	R	T	刀片類型 Inserts	螺絲 Screw	板手 Wrench
MRD0510R-2-100	10	10	100	25	2.5	2	RD..0501MQ..	TS2003	T06
MRD0512R-2-100	12	12	100	25		2			
MRD0512R-3-130	12	12	130	25		3			
MRD0516R-3-130	16	16	130	35	3.5	3	RD..0702MO..	TS2015	T08
MRD0516R-3-180	16	16	180	35		3			
MRD0716R-3-130	16	16	130	40		3			
MRD0716R-3-180	16	16	180	35	4.0	3	RD..0803MO..	TS3002	T10
MRD0720R-4-150	20	20	150	40		4			
MRD0720R-4-200	20	20	200	40		4			
MRD0725R-4-150	25	25	150	40	5.0	4	RD..10T3MO..	TS3504	T15
MRD0725R-4-200	25	25	200	60		4			
MRD0820R-3-150	20	20	150	40		3			
MRD0820R-3-200	20	20	200	45	6.0	3	RD..1204MO..	TS4008	T15
MRD1025R-2-150	25	25	150	45		2			
MRD1025R-2-250	25	25	250	70		2			
MRD1030R-2-150	30	25	150	45	6.0	2	RD..1204MO..	TS4008	T15
MRD1030R-2-250	30	25	250	40		2			
MRD1032R-3-150	32	32	150	45		3			
MRD1032R-3-250	32	32	250	70	6.0	3	RD..1204MO..	TS4008	T15
MRD1232R-2-150	32	32	150	50		2			
MRD1232R-2-250	32	32	250	70		2			
MRD1240R-3-170	40	32	170	45	6.0	3	RD..1204MO..	TS4008	T15
MRD1240R-3-220	40	32	220	45		3			

Unit: mm

MRD 殼型圓刃面銑刀
SHELL TYPE ROUND INSERT
MILLING CUTTER

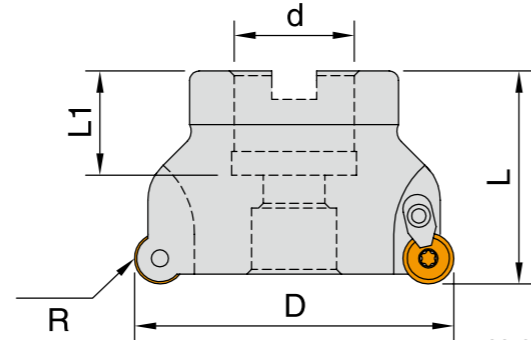
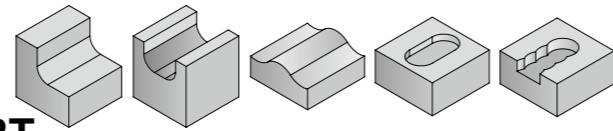

Unit: mm

規格表 Specification

型號 Model	D	d	L	L1	R	T	刀片類型 Inserts	螺絲 Screw	板手 Wrench	壓板 Clamp	螺絲 Screw						
MRD08040-16-5T	40	16	40	18	4	5	RD.. 0803MO...	TS3002	T10	RD-45	TS358						
MRD08050-22-6T	50	22	45	22		6											
MRD10050-22-4T	50	22	45	22	5	4	RD.. 10T3MO...	TS3504	T15	RD-45	TS4009						
MRD10063-22-5T	63	22				5											
MRD12050-22-4T	50	22	45	22	6	4	RD.. 1204MO...	TS4008	T15	RD-6R	TS5004						
MRD12050-22-5T	50	22				5											
MRD12063-22-5T	63	22				5											
MRD12063-22-6T	63	22				6											
MRD12080-27-7T	80	27	50	26	7		RD.. 1604MO...	TS5007	T20	RD-68	TS5009						
MRD12100-32-8T	100	32				32						8					
MRD16063-22-4T-04	63	22	45	22	8	4	RD.. 1604MO...	TS5007	T20	RD-68	TS5009						
MRD16063-22-5T-04	63	22				5											
MRD16080-27-6T-04	80	27	50	26	7		RD.. 1605MO...	TS5007	T20	RD-68	TS5009						
MRD16100-32-7T-04	100	32				32						7					
MRD16125-40-8T-04	125	40	55	36	8	8	RD.. 1605MO...	TS5007	T20	RD-68	TS5009						
MRD16063-22-4T-05	63	22	45	22		4											
MRD16063-22-5T-05	63	22				5											
MRD16080-27-6T-05	80	27	50	26		6							RD.. 1605MO...	TS5007	T20	RD-68	TS5009
MRD16100-32-7T-05	100	32										32					
MRD16125-40-8T-05	125	40	55	36		8											

MRD 鎖牙式圓刃銑刀
THREADED ROUND INSERT
MILLING CUTTER

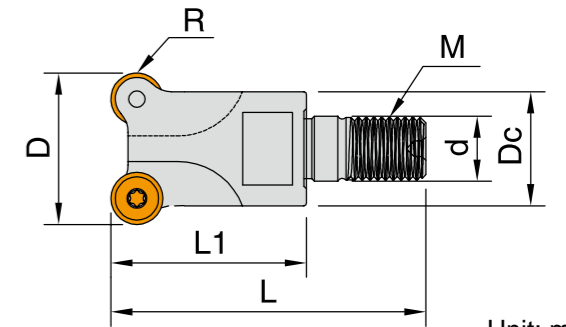
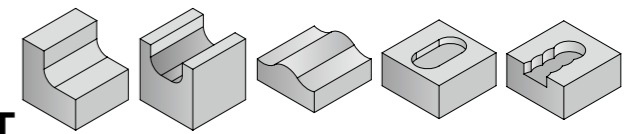

Unit: mm

規格表 Specification

型號 Model	D	Dc	d	L	L1	M	T	刀片類型 Inserts	螺絲 Screw	板手 Wrench
MRD0512R-M06-2	12	11	6.5	36	21	M06	2	RD..0501MO	TS2003	T06
MRD0512R-M06-3	12	11	6.5	36	21	M06	3			
MRD0516R-M08-3	16	15	8.5	43	26	M08	3			
MRD0516R-M08-4	16	15	8.5	43	26	M08	4	RD..0702MO	TS2515	T08
MRD0716R-M08-2	16	15	8.5	43	26	M08	2			
MRD0716R-M08-3	16	15	8.5	43	26	M08	3			
MRD0720R-M10-3	20	18	10.5	50	32	M10	3			
MRD0720R-M10-4	20	18	10.5	50	32	M10	4			
MRD0725R-M12-4	25	23	12.5	60	38	M12	4			
MRD0725R-M12-5	25	23	12.5	60	38	M12	5	RD..0803MO	TS3002	T10
MRD0820R-M10-2	20	23	10.5	50	32	M10	2			
MRD0825R-M12-3	25	23	12.5	60	38	M12	3			
MRD1025R-M12-2	25	23	12.5	60	38	M12	2	RD..1073MO	TS3504	T10
MRD1025R-M12-3	25	23	12.5	60	38	M12	3			
MRD1030R-M12-3	30	23	12.5	60	38	M12	3			
MRD1030R-M12-4	30	23	12.5	60	38	M12	4			
MRD1035R-M12-4	35	29	12.5	63	41	M12	4			
MRD1035R-M12-5	35	29	12.5	63	41	M12	5			
MRD1042R-M16-5	42	29	17	66	43	M16	5			
MRD1042R-M16-6	42	29	17	66	43	M16	6			

AP 直角銑刀
ORTHOGONAL MILLING CUTTER

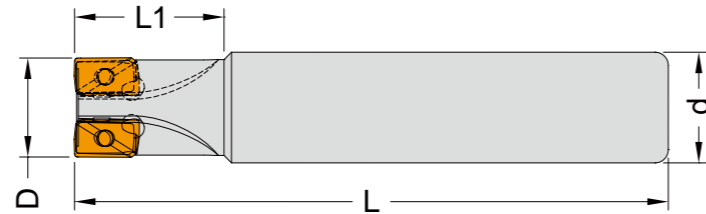
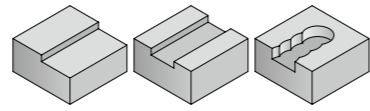

規格表 Specification

型號 Model	D	d	L1	L	T	刀片類型 Inserts	螺絲 Screw	扳手 Wrench
AP10-101-100L	10	12	20	100	1	APKT1003...	TS2515	T08
AP10-121-100L	12	12	25	100	1			
AP10-162-120L	16	16	25	120	2			
AP10-162-160L	16	16	25	160	2			
AP10-172-120L	17	16	25	120	2			
AP10-172-160L	17	16	25	160	2			
AP10-202-120L	20	20	30	120	2			
AP10-202-150L	20	20	30	150	2			
AP10-202-200L	20	20	30	200	2			
AP10-212-150L	21	20	30	150	2			
AP10-212-200L	21	20	30	200	2			
AP10-254-150L	25	25	35	150	4			
AP10-325-150L	32	32	35	150	5			
AP10-406-150L	40	32	35	150	6			
AP16-252-150L	25	25	40	150	2	APKT1604... APEX1604...	TS4004	T15
AP16-252-220L	25	25	40	220	2			
AP16-262-150L	26	25	40	150	2			
AP16-262-220L	26	25	40	220	2			
AP16-322-150L	32	32	45	150	2			
AP16-322-250L	32	32	45	250	2			
AP16-332-150L	33	32	45	150	2			
AP16-353-150L	35	32	45	150	3			
AP16-404-150L	40	32	45	150	4			
AP16-404-250L	40	32	50	250	4			

AP 殼型直角銑刀
SHELL TYPE SHOULDER
CUTTING MILLING CUTTER

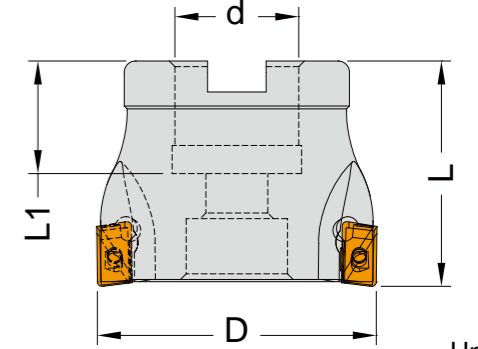
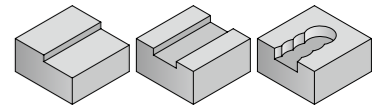

規格表 Specification

型號 Model	D	d	L1	L	T	刀片類型 Inserts	螺絲 Screw	扳手 Wrench
AP10-05006-22	50	22	20	40	6	APKT1003...	TS2515	T08
AP10-06306-22	63	22	21	45	6			
AP10-08007-27	80	27	23	50	7			
AP16-05004-22	100	32	26	55	9	APKT1604... APEX1604...	TS4004	T15
AP16-06305-22	50	22	23	50	4			
AP16-06305-25.4	63	22	23	50	5			
AP16-08006-27	63	25.4	23	50	5			
AP16-08006-25.4	80	27	32	55	6			
AP16-10008-32	80	25.4	32	55	6			
AP16-10008-31.75	100	32	32	55	8			
AP16-10009-32	100	31.75	32	55	8			
AP16-12508-40	125	40	38	63	8			
AP16-12508-38.1	125	38.1	38	63	8			
AP16-16010-40	160	40	38	63	10			
AP16-16010-50.8	160	50.8	38	63	10			

AP10 BT 整體式銑刀
BT SOLID MILLING CUTTER

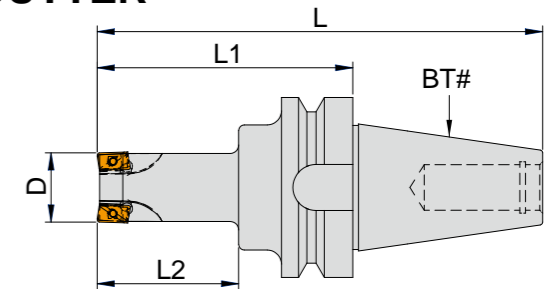
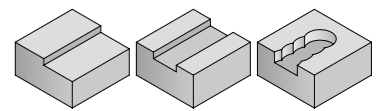

型號 Model	D	L2	L1	L	T	刀片類型 Inserts	螺絲 Screw	扳手 Wrench
BT30-AP10R203-80	20	35	80	129	3	APKT1003..	TS2515	T08
BT30-AP10R253-80	25	45	80	129	3			
BT40-AP10R203-90	20	35	90	156	3			
BT40-AP10R254-90	25	40	90	156	4			

AP 鎖牙式直角銑刀
THREADED ORTHOGONAL MILLING CUTTER

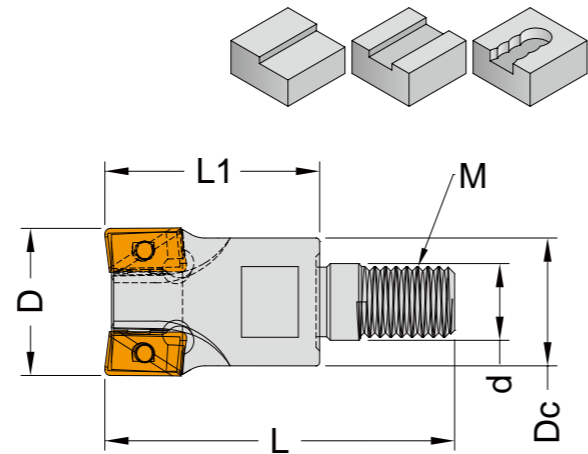

規格表 Specification

型號 Model	D	d	Dc	L1	L	M	T	刀片類型 Inserts	螺絲 Screw	板手 Wrench			
AP10-162-M08	16	8.5	15	26	43	M8	2	APKT1003	TS2515	T08			
AP10-172-M08	17	8.5	15	26	43	M8	2						
AP10-202-M10	20	10.5	18	32	50	M10	2						
AP10-203-M10	20	10.5	18	32	50	M10	3						
AP10-212-M10	21	10.5	18	32	50	M10	2						
AP10-213-M10	21	10.5	18	32	50	M10	3						
AP10-252-M12	25	12.5	23	38	60	M12	2						
AP10-254-M12	25	12.5	23	38	60	M12	4						
AP10-262-M12	26	12.5	23	38	60	M12	2						
AP10-264-M12	26	12.5	23	38	60	M12	4						
AP10-325-M16	32	17	30	41	63	M16	5				APKT1604... APEX1604...	TS4004	T15
AP10-335-M16	33	17	30	41	63	M16	5						
AP10-406-M16	40	17	32	43	65	M16	6						
AP16-252-M12	25	12.5	23	38	60	M12	2						
AP16-262-M16	26	17	23	38	60	M16	2						
AP16-322-M16	32	17	30	41	63	M16	2						
AP16-323-M16	32	17	30	41	63	M16	3						
AP16-332-M16	33	17	30	41	63	M16	2						
AP16-333-M16	33	17	30	41	63	M16	3						
AP16-404-M16	40	17	32	43	65	M16	4						

Unit: mm

AP10, 16 粗銑刀
ROUGH MILLING CUTTER

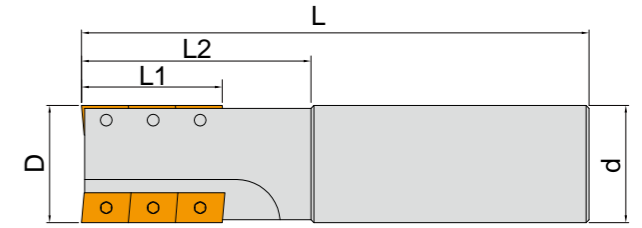

規格表 Specification

型號 Model	D	d	L1	L2	L	T	刀片類型 Inserts	螺絲 Screw	板手 Wrench
AP10R2005S20-028L	20	20	28	42	107	1	APKT1003...	TS2515	T08
AP10R2508S25-037L	25	25	37	50	125	2			
AP10R3215S32-046L	32	32	46	60	135	3			
AP16R3206S32-042L	32	32	42	55	135	2	APKT1604...	TS4023	T15
AP16R4010S32-068L	40	32	68	94	175	2			
AP16R4015S32-068L	40	32	68	94	175	3			
AP16R5024S50.8-100L	50	50.8	100	128	224	3			
AP16R5036S50.8-158L	50	50.8	158	188	284	3			

Unit: mm

AP16 殼型粗銑刀
SHELL TYPE ROUGH MILLING CUTTER

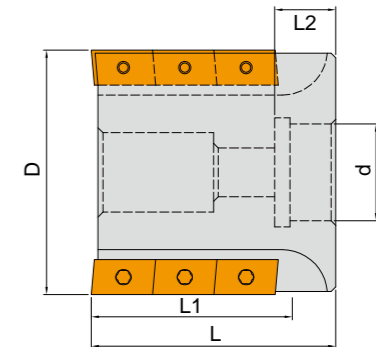

規格表 Specification

型號 Model	D	d	L1	L2	L	T	刀片類型 Inserts	螺絲 Screw	板手 Wrench
AP16R05009-45-22.0	50	22	45	21	64	3	APKT160408 APEX160408	TS4023	T15
AP16R06312-45-25.4	63	25.4	45	38	64	4			
AP16R06320-68-25.4	63	25.4	68	38	90	4			

Unit: mm

RP 圓刃銑刀
ROUND INSERT
MILLING CUTTER

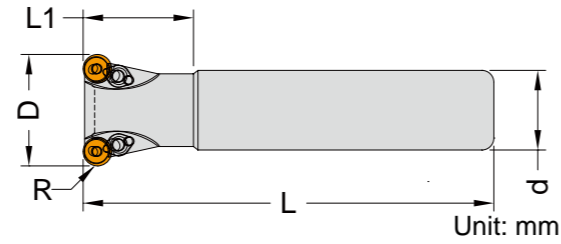
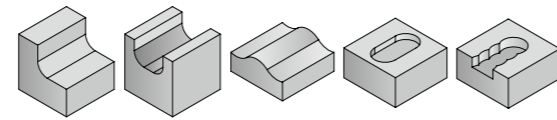

規格表 Specification

型號 Model	D	d	L1	L	R	T	刀片類型 Inserts	刀片螺絲 Screw	壓板 Ciamp	壓板螺絲 Ciamp Screw	板手 Wrench
RP0612SN12-100-2T	12	12	25	100	3	2	RPMT0602MO	TS2507	-	-	T08
RP0612SN16-120-2T	12	16	50	120	3	2					
RP0616SN16-150-2T	16	16	30	150	3	2					
RP0820SN20-150-2T	20	20	30	150	4	2	RPMT0803MO	TS3007	-	-	T10
RP0825SN25-150-3T	25	25	35	150	4	3					
RP1025SN25-150-2T	25	25	35	150	5	2	RPMT10T3MO	TS4009	RP-5R	TS3503	T15
RP1025SN25-200-2T	25	25	50	200	5	2					
RP1030SN25-150-2T	30	25	35	150	5	2					
RP1030SN25-200-2T	30	25	35	200	5	2					
RP1035SN32-150-3T	35	32	40	150	5	3					
RP1035SN32-200-3T	35	32	40	200	5	3					
RP1232SN25-200-2T	32	25	40	200	6	2	RPMT1204MO	TS4009	RP-6R	TS5007	T15
RP1232SN32-200-2T	32	32	50	200	6	2					
RP1240SN32-180-3T	40	32	50	180	6	3					
RP1240SN32-230-3T	40	32	60	230	6	3					

RP 殼型圓刃銑刀
SHELL TYPE ROUND INSERT
MILLING CUTTER

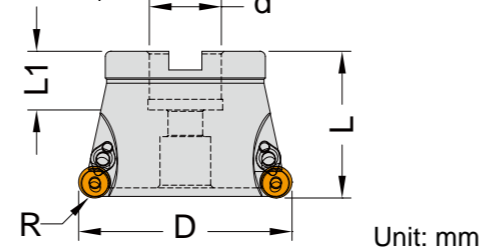
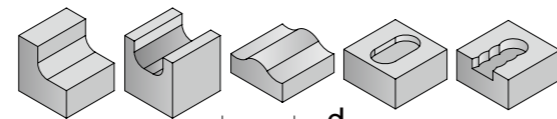

規格表 Specification

型號 Model	D	d	L1	L	R	T	刀片類型 Inserts	刀片螺絲 Screw	壓板 Ciamp	壓板螺絲 Ciamp Screw	板手 Wrench
RP10050-22.0-4T	50	22	21	50	5	4	RPMT10T3MO	TS4009	RP-5R	TS3503	T15
RP10063-22.0-5T	63	22	21	50	5	5					
RP12050-22.0-4T	50	22	21	50	6	4	RPMT1204MO	TS4009	RP-6R	TS5007	T15
RP12063-22.0-3T	63	22	21	50	6	3					
RP12063-22.0-4T	63	22	21	50	6	4					
RP12063-22.0-5T	63	22	21	50	6	5					
RP12063-25.4-5T	63	25.4	21	50	6	5					
RP12080-27.0-5T	80	27	23	50	6	5					

R390 直角銑刀
ORTHOGONAL
MILLING CUTTER

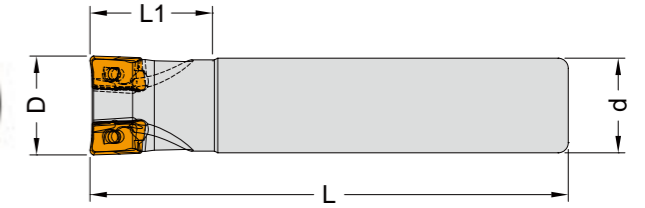
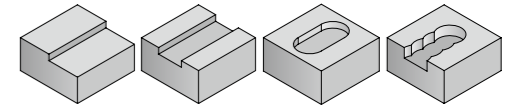

規格表 Specification

型號 Model	D	d	L1	L	T	刀片類型 Inserts	螺絲 Screw	板手 Wrench
R390-11-121-100L	12	16	25	100	1	R390-11T3	TS2515	T08
R390-11-162-150L	16	16	30	150	2			
R390-11-172-150L	17	16	30	150	2			
R390-11-182-150L	18	16	30	150	2			
R390-11-202-150L	20	20	30	150	2			
R390-11-203-150L	20	20	30	150	3			
R390-11-212-150L	21	20	30	150	2			
R390-11-223-150L	22	20	30	150	3			
R390-11-252-150L	25	25	30	150	2			
R390-11-253-150L	25	25	30	150	3			
R390-11-303-150L	30	25	30	150	3			
R390-11-323-150L	32	32	35	150	3			
R390-11-325-150L	32	32	35	150	5			
R390-11-333-150L	33	32	35	150	3			
R390-11-335-150L	33	32	35	150	5			
R390-11-353-150L	35	32	35	150	3			
R390-11-355-150L	35	32	35	150	5			
R390-11-404-150L	40	32	35	150	4			
R390-11-406-150L	40	32	35	150	6			
R390-17-252-150L	25	25	40	150	2			
R390-17-262-150L	26	25	40	150	2			
R390-17-282-150L	28	25	40	150	2			
R390-17-302-150L	30	25	40	150	2			
R390-17-322-150L	32	32	45	150	2			
R390-17-323-150L	32	32	45	150	3			
R390-17-332-150L	33	32	45	150	2			
R390-17-333-150L	33	32	45	150	3			
R390-17-353-150L	35	32	45	150	3			
R390-17-404-150L	40	32	45	150	4			

R390 殼型直角銑刀
SHELL TYPE ORTHOGONAL
MILLING CUTTER

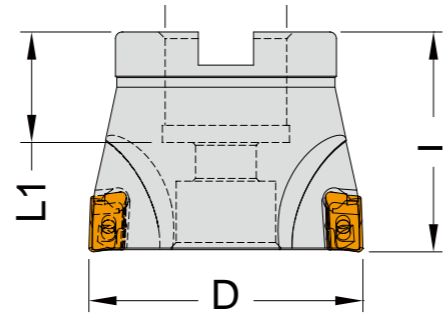
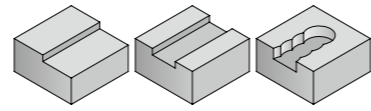

Unit: mm

規格表 Specification

型號 Model	D	d	Dc	L1	L	T	刀片類型 Inserts	螺絲 Screw	板手 Wrench
R390-11-05004-22	50	22	42	21	40	4	R390-11T304M-...	TS2515	T08
R390-11-05005-22	50	22	42	21	40	5			
R390-11-06305-22	63	22	50	21	40	5			
R390-11-06306-22	63	22	50	21	40	6			
R390-11-08006-27	80	27	60	23	50	6			
R390-11-08008-27	80	27	60	23	50	8			
R390-11-10007-32	100	32	70	23	50	7			
R390-11-10010-32	100	32	70	23	50	10			
R390-17-05004-22	50	22	42	21	40	4	R390-170408M-...	TS4005	T15
R390-17-06305-22	63	22	50	21	40	5			
R390-17-08006-27	80	27	60	23	50	6			
R390-17-10007-32	100	32	70	23	50	7			
R390-17-12508-40	125	40	80	32	63	8			
R390-17-16010-40	160	40	90	32	63	10			

R390 鎖牙式直角銑刀
THREADED ORTHOGONAL
MILLING CUTTER

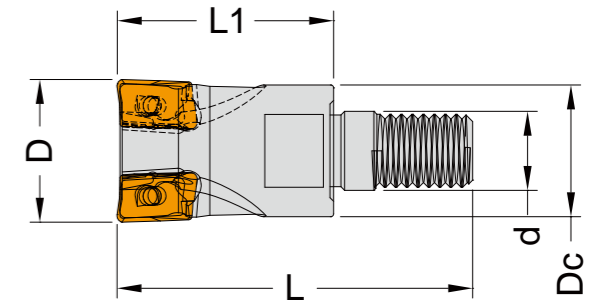
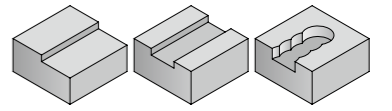

Unit: mm

規格表 Specification

型號 Model	D	d	Dc	L1	L	T	刀片類型 Inserts	螺絲 Screw	板手 Wrench
R390-11-121-M06	12	6.5	11	24	40	1	R390-11T304M-...	TS2515	T08
R390-11-162-M08	16	8.5	15	26	43	2			
R390-11-172-M08	17	8.5	15	26	43	2			
R390-11-182-M08	18	8.5	15	32	43	2			
R390-11-202-M10	20	10.5	18	32	50	2			
R390-11-203-M10	20	10.5	18	32	50	3			
R390-11-212-M10	21	10.5	18	32	50	2			
R390-11-223-M10	22	10.5	18	32	50	3			
R390-11-252-M12	25	12.5	23	38	60	2			
R390-11-253-M12	25	12.5	23	38	60	3			
R390-11-303-M12	30	12.5	23	41	60	3			
R390-11-323-M16	32	17	29	41	63	3			
R390-11-325-M16	32	17	29	41	63	5			
R390-11-333-M16	33	17	29	41	63	3			
R390-11-335-M16	33	17	29	41	63	5			
R390-11-353-M16	35	17	32	41	63	3			
R390-11-355-M16	35	17	32	41	63	5			
R390-11-404-M16	40	17	32	43	65	4			
R390-11-406-M16	40	17	32	43	65	6			
R390-17-252-M12	25	12.5	23	38	60	2			
R390-17-262-M12	26	12.5	23	38	60	2			
R390-17-282-M12	28	12.5	25	38	60	2			
R390-17-302-M12	30	12.5	25	38	60	2			
R390-17-322-M16	32	17	29	41	63	2			
R390-17-323-M16	32	17	29	41	63	3			
R390-17-332-M16	33	17	29	41	63	2			
R390-17-333-M16	33	17	29	41	63	3			
R390-17-353-M16	35	17	32	41	63	3			
R390-17-404-M16	40	17	32	43	65	4			

R390 粗銑刀
ROUGH MILLING CUTTER

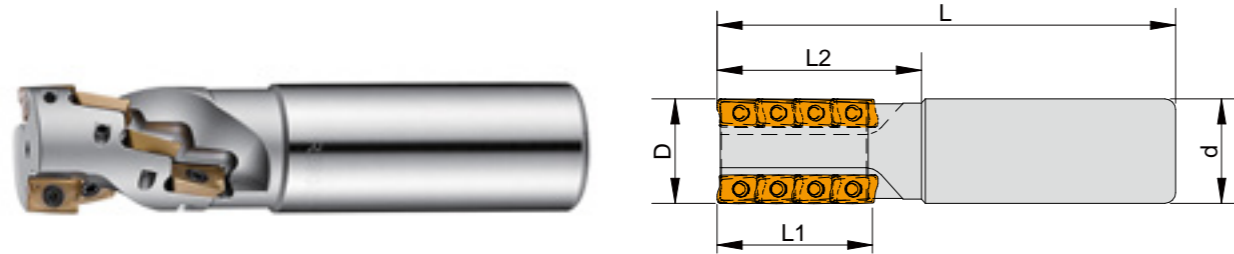
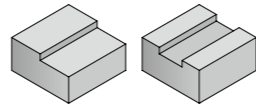

規格表 Specification

型號 Model	D	d	L1	L2	L	T	刀片類型 Inserts	螺絲 Screw	板手 Wrench
R3902508S25-040L	24	25	40	50	110	2	R390-11T304M..	TS2515	T08
R3903208S32-036L	32	32	36	50	112	2			
R3903212S32-046L	32	32	36	50	125	3			

Unit: mm

R390 BT 整體式銑刀
BT HOLDER MILLING CUTTER

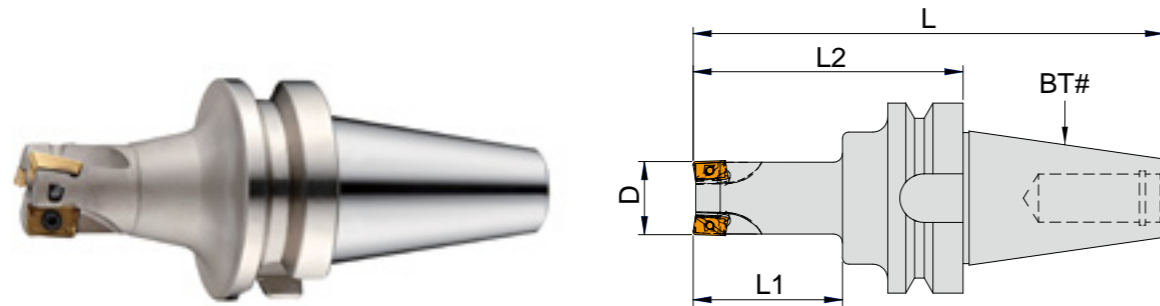
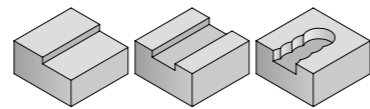

規格表 Specification

型號 Model	D	L1	L2	L	T	刀片類型 Inserts	螺絲 Screw	板手 Wrench
BT30-R390203-80	20	35	80	129	3	R390-11T3..	TS2515	T08
BT30-R390253-80	25	45	80	129	3			
BT40-R390203-90	20	35	90	156	3			
BT40-R390253-65	25	22	65	132.4	3			

Unit: mm

XO 直角高速銑刀
ORTHOGONAL HIGH SPEED
END MILL

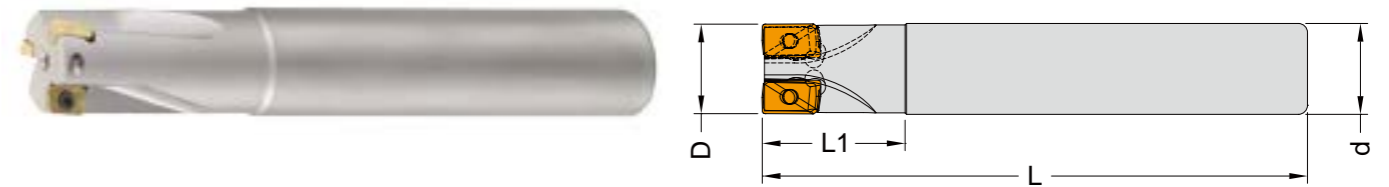
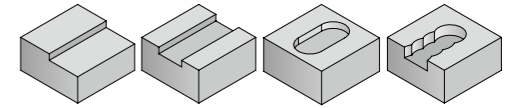

規格表 Specification

型號 Model	D	d	L1	L	T	刀片類型 Inserts	螺絲 Screw	板手 Wrench
XOS06-10-100L-2T	10	10	20	100	2	XOMX060204...	TS1801	T06
XOS06-11-100L-2T	11	10	20	100	2			
XOS06-12-100L-2T	12	12	20	100	2			
XOS06-12-100L-3T	12	12	20	100	3			
XOS06-13-100L-2T	13	12	20	100	2			
XOS06-13-100L-3T	13	12	20	100	3			
XOS06-16-100L-3T	16	16	30	100	3			
XOS06-16-120L-4T	16	16	30	120	4			
XOS06-17-120L-4T	17	16	30	120	4			
XOS06-20-120L-5T	20	20	30	120	5			
XOS06-21-120L-5T	21	20	30	120	5	XOMX09038...	TS2502	T08
XOS09-16-120L-2T	16	16	25	120	2			
XOS09-17-120L-2T	17	16	25	120	2			
XOS09-20-120L-3T	20	20	30	120	3			
XOS09-21-120L-3T	21	20	30	120	3			
XOS09-25-150L-4T	25	25	30	150	4			
XOS09-26-150L-4T	26	25	30	150	4			
XOS09-32-150L-5T	32	32	35	150	5			
XOS09-33-150L-5T	33	32	35	150	5			
XOS09-35-150L-6T	35	32	30	150	6			

Unit: mm

CDM 側銑刀 SIDE MILLING CUTTER

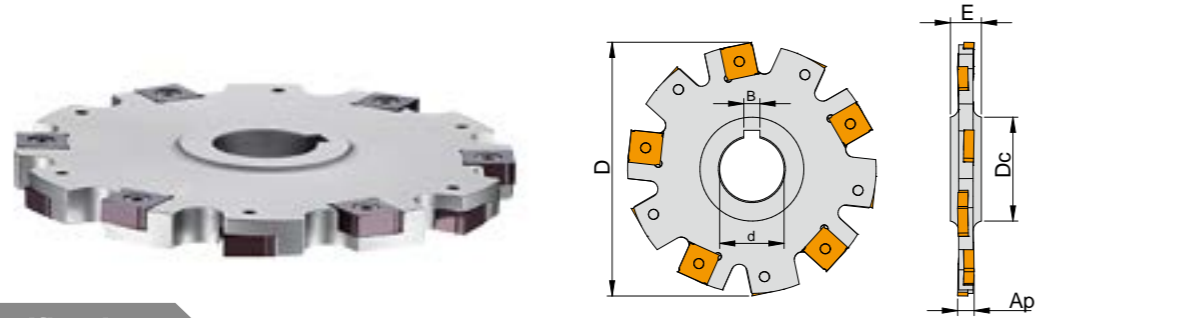

規格表 Specification

型號 Model	D	Dc	d	E	B	T	Ap	刀片類型 Inserts	螺絲 Screw	板手 Wrench					
CDM080-08-25.4-09T	80					3x3	4	SNFX1203	TS4012	T15					
CDM080-08-25.4-08T						3x4	4	SNFX1245	TS4011	T10					
CDM100-04-25.4-12T	100	42		12		6x2	4	SNFX1102	TS3008	T07					
CDM100-05-25.4-12T						6x2	5	SNFX1103	TS3009						
CDM100-06-25.4-10T						5x2	6	SNFX1203	TS4012	T15					
CDM100-07-25.4-09T						3x3	7								
CDM100-08-25.4-09T						3x3	8								
CDM100-10-25.4-10T						5x2	10	SNFX1205	TS4011						
CDM100-11-25.4-10T						5x2	11	SNFX1207	TS4021						
CDM100-12-25.4-10T						5x2	12								
CDM100-14-25.4-09T								16		3x3	14				
CDM125-04-25.4-14T						125	42	25.4	12	6.35	7x2	4	SNFX1102	TS3008	T07
CDM125-06-25.4-12T	6x2	6	SNFX1203	TS4012											
CDM125-08-25.4-12T	3x4	8													
CDM125-09-25.4-12T	6x2	9	SNFX1205	TS4011	T15										
CDM125-10-25.4-12T	6x2	10													
CDM125-12-25.4-12T	6x2	12													
CDM125-14-25.4-12T	4x3	14	SNFX1207	TS4021											
CDM140-15-25.4-15T	140	50		16							5x3	15			
CDM160-06-25.4-16T	160	42		12							8x2	6	SNFX1203	TS4012	T15
CDM160-08-25.4-15T											5x3	8			
CDM160-10-25.4-16T						8x2	10	SNFX1205	TS4011						
CDM160-12-25.4-16T						8x2	12	SNFX1207	TS4021						
CDM160-14-25.4-15T						5x3	14								

Unit: mm

CDM 側銑刀 SIDE MILLING CUTTER

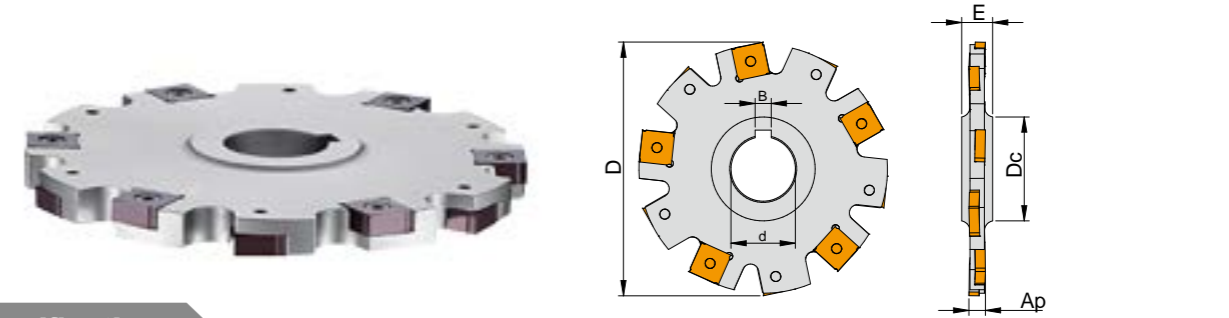

規格表 Specification

型號 Model	D	Dc	d	E	B	T	Ap	刀片類型 Inserts	螺絲 Screw	板手 Wrench	
CDM063-04-22-08T	63	38	22	8	6	4x2	4	SNFX1102	TS3008	T07	
CDM063-05-22-08T						4x2	5	SNFX1103	TS3009		
CDM063-06-22-06T						3x2	6	SNFX1203	TS4012		
CDM063-08-22-06T						3x2	8				
CDM080-04-22-10T	80	38	22	8	6	5x2	4	SNFX1102	TS3008	T07	
CDM080-05-22-10T						5x2	5	SNFX1103	TS3009		
CDM080-06-22-08T						4x2	6	SNFX1203	TS4012	T15	
CDM080-08-22-09T						3x3	8				
CDM100-04-22-12T	100	41	27	12	6.3	6x2	4	SNFX1102	TS3008		T07
CDM100-05-22-12T						6x2	5	SNFX1103	TS3009		
CDM100-06-22-10T						5x2	6	SNFX1203	TS4012		
CDM100-08-22-09T						3x3	8				
CDM100-10-22-10T						5x2	10	SNFX1205	TS4011		
CDM100-12-22-10T						5x2	12	SNFX1207	TS4021		
CDM110-12-22-10T	110	46	22	12	6.35	5x2	12			T15	
CDM125-06-32-12T	125	54	32	12	10	6x2	6	SNFX1203	TS4012		
CDM125-07-40-12T		58	40	12	10	4x3	7.2				
CDM125-10-40-12T		58	40	12	10	6x2	10	SNFX1205	TS4011		
CDM130-09-32-16T	130	52	32	10	8	8x2	9				
CDM160-06-40-16T	160	54	40	12	10	8x2	6	SNFX1203	TS4012		
CDM160-08-40-15T						5x3	8				
CDM160-10-40-16T						8x2	10	SNFX1205	TS4011		
CDM160-12-40-16T						8x2	12	SNFX1207	TS4021		
CDM160-14-40-15T						5x3	14				
CDM200-12-50-18T						200	75	50	16	12	6x3

Unit: mm

GDM 殼型側銑刀
SHELL TYPE ORTHOGONAL
MILLING CUTTER

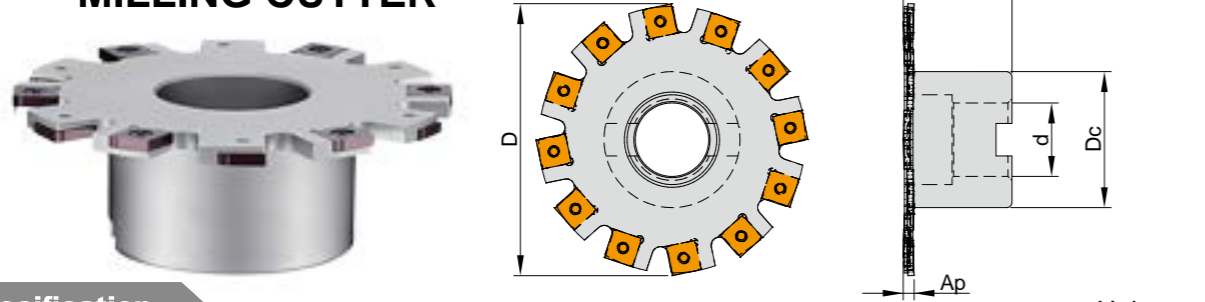

規格表 Specification

型號 Model	D	Dc	d	L	T	Ap	刀片類型 Inserts	螺絲 Screw	板手 Wrench	
GDM080-04-22-10T	80	45	22	40	5x2	4	SNFX1102	TS3008	T07	
GDM080-05-22-10T					5x2	5	SNFX1103	TS3009		
GDM080-06-22-08T					4x2	6	SNFX1203	TS4012	T15	
GDM080-07-22-09T					3x3	7				
GDM080-08-22-09T					3x3	8				
GDM080-09-22-08T					4x2	9	SNFX1205	TS4011		
GDM080-10-22-08T					4x2	10	SNFX1207	TS4021		
GDM080-12-22-08T					4x2	12				
GDM080-14-22-09T					3x3	14				
GDM100-04-27-12T					100	50	27	40		6x2
GDM100-05-27-12T	6x2	5	SNFX1103	TS3009						
GDM100-06-27-10T	5x2	6	SNFX1203	TS4012						T15
GDM100-07-27-09T	3x3	7								
GDM100-08-27-09T	3x3	8								
GDM100-09-27-10T	5x2	9	SNFX1205	TS4011						
GDM100-10-27-10T	5x2	10	SNFX1207	TS4021						
GDM100-12-27-10T	5x2	12								
GDM100-14-27-09T	3x3	14								
GDM125-04-32-14T	125	70	32	45					7x2	
GDM125-05-32-14T					7x2	5	SNFX1103	TS3009		
GDM125-06-32-12T					6x2	6	SNFX1203	TS4012	T15	
GDM125-07-32-12T					3x4	7				
GDM125-08-32-12T					3x4	8				
GDM125-09-32-12T					6x2	9	SNFX1205	TS4011		
GDM125-10-32-12T					6x2	10	SNFX1207	TS4021		
GDM125-12-32-12T					6x2	12				
GDM125-14-32-12T					4x3	14				
GDM160-06-40-16T					160	90	40	50		8x2
GDM160-07-40-15T	5x3	7								
GDM160-08-40-15T	5x3	8	SNFX1205	TS4011						
GDM160-09-40-16T	8x2	9								
GDM160-10-40-16T	8x2	10								
GDM160-12-40-16T	8x2	12	SNFX1207	TS4021						
GDM160-14-40-15T	5x3	14								

SN1205 殼型刨削銑刀
SHELL TYPE PLANING
MILLING CUTTER

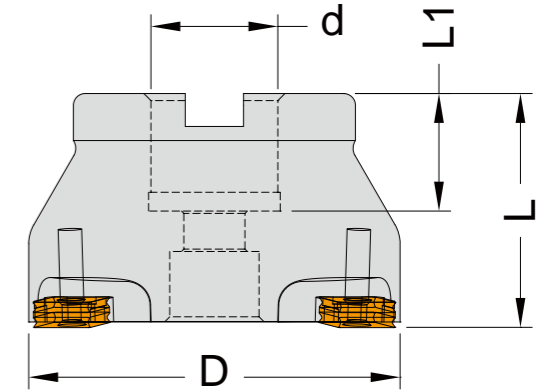

規格表 Specification

型號 Model	D	d	L1	L	T	刀片類型 Inserts	螺絲 Screw	板手 Wrench
SN1205-06302-22	63	22	21	45	2	SN-1205	TS4021	T15
SN1205-08002-27	80	27	23	50	2			
SN1205-10002-32	100	32	26	55	2			
SN1205-12504-40	125	40	36	63	4			
SN1205-16004-40	160	40	36	63	4			

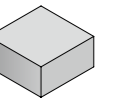

AKM 45°殼型鋁合金銑刀
45° SHELL TYPE ALUMINUM ALLOY CUTTER

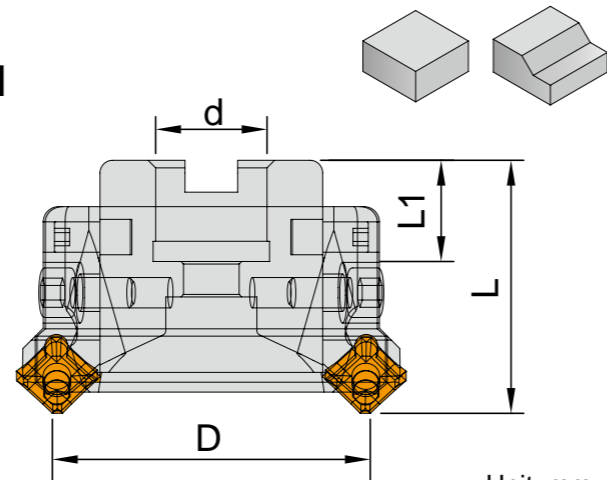

規格表 Specification

型號 Model	D	d	L1	L	T	刀片類型 Inserts	螺絲 Screw	板手 Wrench
AKM-06304R-22	63	22	22	50	4	SEHT1204AFFN	TS5006	T20
AKM-08004R-22	80	22	23		4			
AKM-10006R-27	100	27	28		6			
AKM-12508R-32	125	32	28		8			
AKM-16008R-40	160	40	32	55	8			
AKM-20010R-40	200	40	32		10			
AKM-25012R-40	250	40	32		12			
AKM-31514R-40	315	40	32		14			
AKM-35012R-40	350	40	32		12			

刀座 Tool Holder	刀座螺絲 Tool Holder Screw	調整螺絲 Adj. Screw
AKM-G01	TSI601	S6-LR

AAP 殼型直角鋁合金銑刀
SHELL TYPE ORTHOGONAL ALUMINUM ALLOY CUTTER

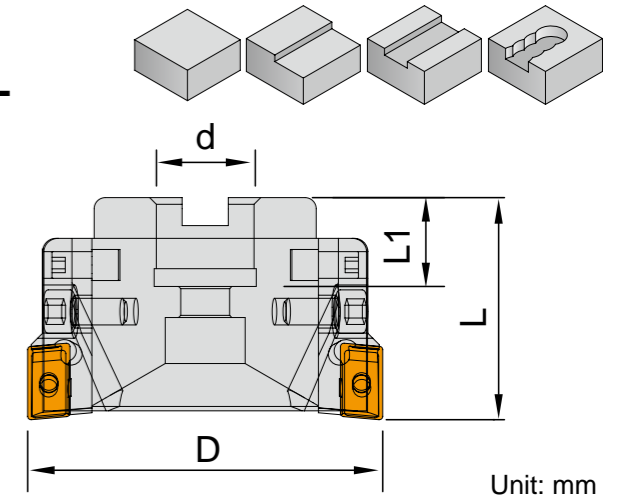

規格表 Specification

型號 Model	D	d	L1	L	T	刀片類型 Inserts	螺絲 Screw	板手 Wrench
AAP-06303R-22	63	22	20	63	3	APEX1604..PDER	TS4004	T15
AAP-08004R-22	80	22	23	50	4			
AAP-10006R-27	100	27	28		6			
AAP-12508R-32	125	32	28		8			
AAP-16008R-40	160	40	32		55			
AAP-20010R-40	200	40	32	10				
AAP-25010R-40	250	40	32	10				
AAP-31512R-40	315	40	32	12				
AAP-35016R-40	350	40	32	16				

刀座 Tool Holder	刀座螺絲 Tool Holder Screw	調整螺絲 Adj. Screw
AAP-G01	TSI601	S6-LR

SE445 平面銑刀
FACE MILLING CUTTER

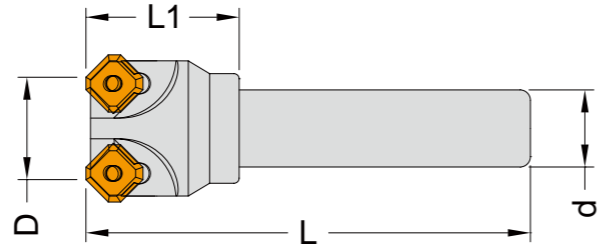
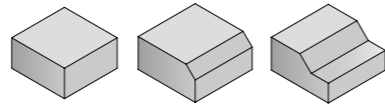

規格表 Specification

Unit: mm

型號 Model	D	d	L1	L	T	刀片類型 Inserts	螺絲 Screw	板手 Wrench
SE445R232S20	32	20	45	110	2	SE..1204AFER..	TS5006	T20
SE445R340S20	40	20	45	110	3			
SE445R450S20	50	20	45	120	4			
SE445R450S25	50	25	45	120	4			
SE445R563S25	63	25	45	120	5			
SE445R563S32	63	32	45	120	5			

SE445 R/L 45° 平面銑刀
45° FACE MILLING CUTTER

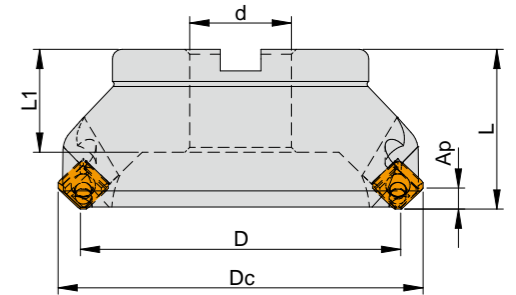
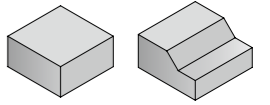

規格表 Specification

ISO
Unit: mm

型號 Model	D	Dc	d1	L	L1	Ap	T	刀片類型 Inserts	螺絲 Screw	板手 Wrench
SE445R050-22-4T	50	64	22	40	20	4	4	SE..1204AFER-..	TS5006	T20
SE445R063-22-5T	63	77	22	45	21		5			
SE445R063-25.4-5T	63	77	25.4							
SE445R080-27-6T	80	94	27	50	26		6			
SE445R080-31.75-6T	80	94	31.75							
SE445R100-32-6T	100	114	32							
SE445R100-31.75-6T	100	114	31.75	63	38		6			
SE445R125-40-8T	125	139	40				8			
SE445R125-38.1-8T	125	139	38.1				10			
SE445R160-40-10T	160	174	40							
SE445R160-50.8-10T	160	174	50.8							
SE445R200-47.625-12T	200	214	47.625							
SE445R250-47.625-14T	250	264	47.625	14						

Unit: mm

型號 Model	D	Dc	d1	L	L1	Ap	T	刀片類型 Inserts	螺絲 Screw	板手 Wrench
SE445L050-22-4T	50	64	22	40	20	4	4	SE..1204AFER-..	TS5006	T20
SE445L063-22-5T	63	77	22	45	21		5			
SE445L063-25.4-5T	63	77	25.4							
SE445L080-27-6T	80	94	27	50	26		6			
SE445L080-31.75-6T	80	94	31.75							
SE445L100-32-6T	100	114	32							
SE445L100-31.75-6T	100	114	31.75	63	38		6			
SE445L125-40-8T	125	139	40				8			
SE445L125-38.1-8T	125	139	38.1				10			
SE445L160-40-10T	160	174	40							
SE445L160-50.8-10T	160	174	50.8							
SE445L200-47.625-12T	200	214	47.625							
SE445L250-47.625-14T	250	264	47.625	14						

SKE90 直角銑刀
ORTHOGONAL MILLING CUTTER

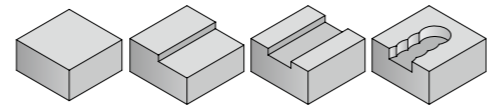
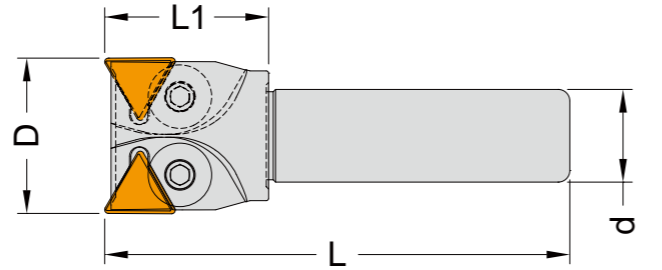

規格表 Specification

型號 Model	D	d	L1	L	T	刀片類型 Inserts	螺絲 Screw	板手 Wrench
SKE90-2020-090L-2T	20	20	30	90	2	TPMN110204	MP05	LK03
SKE90-2520-100L-2T	25	20	30	100	2	TPMN110304	MP05	LK03
SKE90-3020-100L-2T	30	20	30	100	2	TPMN160308 TPKN1603PDR	MP06	LK04
SKE90-3520-100L-2T	35	20	40	100	2			
SKE90-3525-105L-2T	35	25	40	105	2			
SKE90-3532-110L-2T	35	32	40	110	2			
SKE90-4020-110L-3T	40	20	40	110	3			
SKE90-4025-110L-3T	40	25	40	110	3			
SKE90-4032-115L-3T	40	32	40	115	3			
SKE90-4520-105L-3T	45	20	40	105	3			
SKE90-5020-105L-3T	50	20	40	105	3			
SKE90-5025-110L-3T	50	25	40	110	3			
SKE90-5032-115L-3T	50	32	40	115	3	TPMN220412	MP08	LK05
SKE90-6332-125L-3T	63	32	40	125	3			

Unit: mm

SKE45 斜度銑刀
TAPER MILLING CUTTER

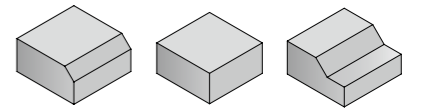
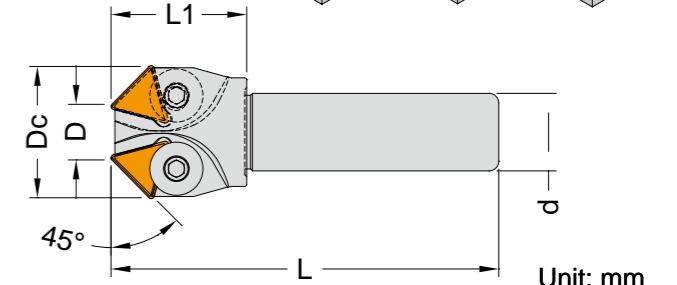

規格表 Specification

型號 Model	D	Dc	d	L1	L	T	刀片類型 Inserts	螺絲 Screw	板手 Wrench
SKE45-1232-115L-2T	12	32	20	40	115	2	TPMN160308	MP06	L04
SKE45-2050-125L-3T	20	50	32	45	125	3	TPMN220412	MP08	L05
SKE45-3563-145L-3T	35	63	32	50	145	3	TPMN220412	MP08	L05

Unit: mm

SKE30 斜度銑刀
TAPER MILLING CUTTER

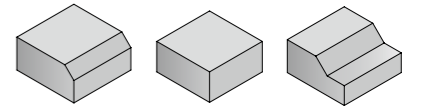
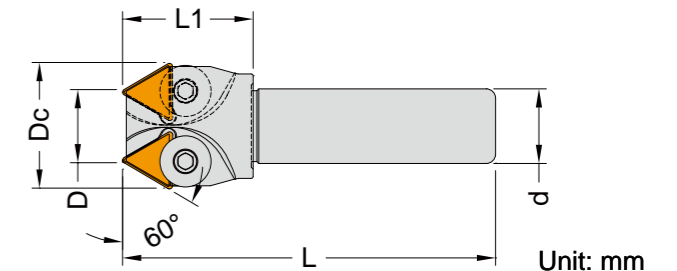

規格表 Specification

型號 Model	D	Dc	d	L1	L	T	刀片類型 Inserts	螺絲 Screw	板手 Wrench
SKE30-2032-125L-2T	20	32	20	40	125	2	TPMN160308	MP06	L04
SKE30-3042-125L-3T	30	42	25	40	125	3			
SKE30-4052-125L-3T	40	52	32	40	125	3			

Unit: mm

SKE60 斜度銑刀
TAPER MILLING CUTTER

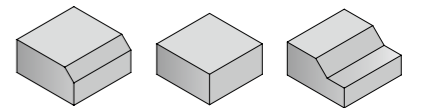
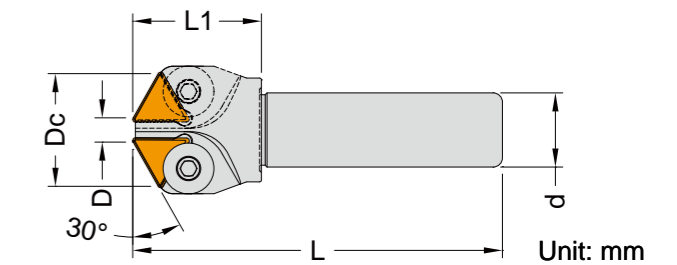

規格表 Specification

型號 Model	D	Dc	d	L1	L	T	刀片類型 Inserts	螺絲 Screw	板手 Wrench
SKE60-1030-125L-2T	10	30	20	35	125	2	TPMN110308	MP05	L03
SKE60-3050-125L-3T	30	50	25	40	125	3	TPMN160308	MP06	L04

Unit: mm

DC07, 11 斜度銑刀(鳩尾刀)
DOVETAIL MILLING CUTTER

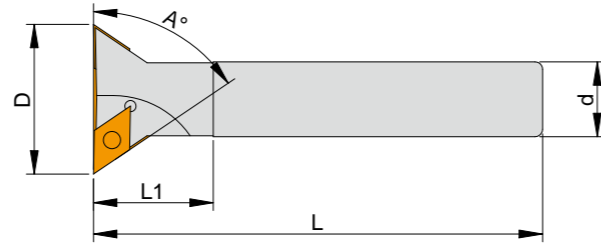
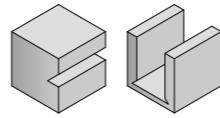

規格表 Specification

型號 Model	D	d	L1	L	A°	T	刀片類型 Inserts	螺絲 Screw	板手 Wrench
DC07-D25-2T-56-120L	25	20	32	130	56	2	DCMT070204	TS2515	T08
DC07-D30-2T-56-130L	30	20	32	130		2			
DC07-D35-3T-56-130L	35	20	32	130		3			
DC07-D40-4T-56-130L	40	20	32	130		4			
DC07-D25-2T-60-120L	25	20	20	120	60	2	DCMT070204	TS2515	T08
DC07-D30-2T-60-130L	30	20	32	130		2			
DC07-D35-3T-60-130L	35	20	32	130		3			
DC07-D40-4T-60-130L	40	20	32	130		4			
DC11-D40-3T-60-150L	40	25	32	150	60	3	DCMT11T3..	TS4006	T15
DC11-D50-3T-60-150L	50	25	32	150		3			
DC11-D60-4T-60-150L	60	32	32	150		4			

Unit: mm

DC11 斜度殼型銑刀
SHELL TYPE TAPERED MILLING CUTTER

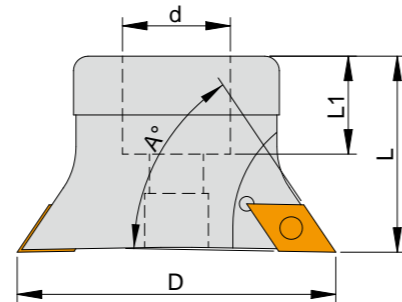
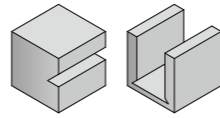

規格表 Specification

型號 Model	D	d	L1	L	A°	T	刀片類型 Inserts	螺絲 Screw	板手 Wrench
DC11-06503R-22	65	22	20	40	60	3	DCMT11T3..	TS4006	T15
DC11-08005R-22	80	22	20	45		5			

Unit: mm

SST 定位倒角刀
POSITIONING CHAMFERING CUTTER

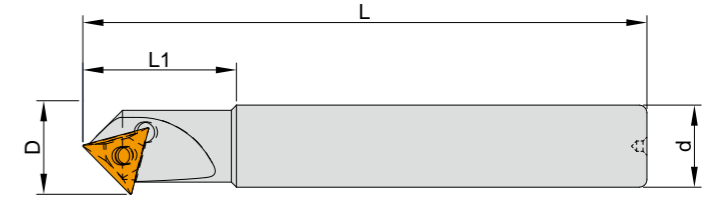

規格表 Specification

型號 Model	D	d	L1	L	T	刀片類型 Inserts	螺絲 Screw	板手 Wrench
SST-1212-105L	12	12	25	105	1	TCEX100304E	TS2507	T08
SST-1616-110L	16	16	30	110	1	TCEX13T302E	TS3508	T15
SST-2012-100L	20	12	35	100	1	TCMX16T308E	TS4009	T15
SST-2020-130L	20	20	50	130	1	TCMX16T308E	TS4009	T15

Unit: mm

SSA 定位倒角刀
POSITIONING CHAMFERING CUTTER

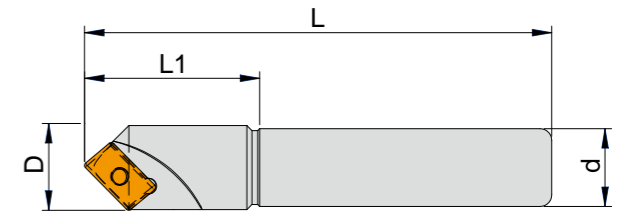

規格表 Specification

型號 Model	D	d	L1	L	T	刀片類型 Inserts	螺絲 Screw	板手 Wrench
SSA-2020-130L	20	20	35	130	1	ADNT160308SR	TS4004	T15

Unit: mm

DBR 背搪刀
BACK BORING CUTTER

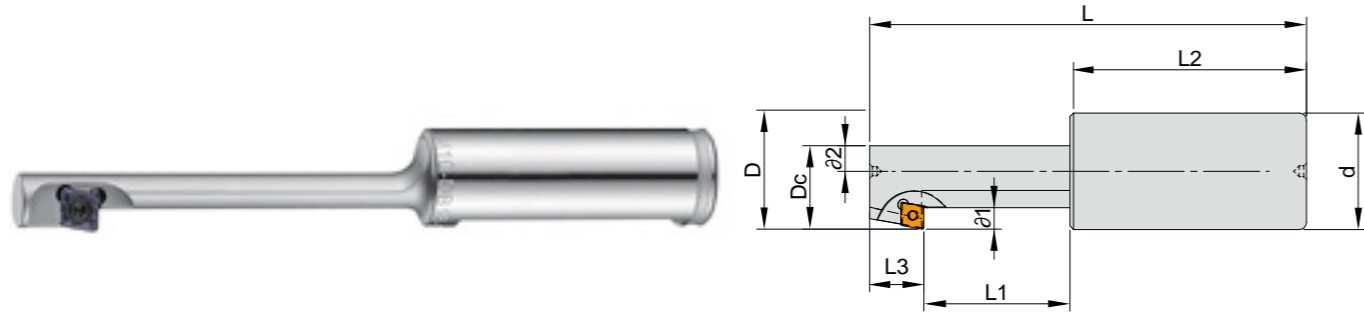

規格表 Specification		Unit: mm										
型號 Model	D	Dc	ø1	ø2	d	L	L1	L2	L3	刀片類型 Inserts	螺絲 Screw	板手 Wrench
M08-DB14-C20-063L	14	8.8	2.7	1.8	20	130	63	50	13	CCMT 060204	TS2507	T08
M10-DB18-C16-035L	18	10.5	3.9	1.5	16	101	35	48				
M10-DB18-C16-050L	18	10.5	3.9	1.5	16	116	50	48				
M12-DB19-C16-035L	19	12	3.7	2.5	16	101	35	48				
M16-DB25-C25-060L	25	16	4.4	3.5	25	160	80	60	15	CCMT 09T304	TS4004	T15
M18-DB28-C25-060L	28	18	5	4	25	175	95	60				
M20-DB31-C32-075L	31	20	5.4	5	32	180	95	65				
M24-DB38-C32-090L	38	24	7.4	5	32	195	110	65				
M30-DB46-C32-100L	46	30	8.4	7	32	205	120	65				

MFH01 殼型高進給銑刀
HIGH FEED MILLING CUTTER



規格表 Specification		Unit: mm								
型號 Model	D	d	L	L1	T	刀片 Insert	螺絲 Screw	板手 Wrench		
MFH01-08-100-1T	8	8	100	20	1	LPGT010210...	TS2001	T6		
MFH01-09-100-1T	9	8	100	20	1					
MFH01-11-100-3T	11	10	100	20	3					
MFH01-13-100-3T	13	12	100	20	3					

MFH01 鎖牙式高進給精修銑刀
TREADED HIGH FEED MILLING CUTTER



規格表 Specification		Unit: mm								
型號 Model	D	d	L	L1	M	T	刀片 Insert	螺絲 Screw	板手 Wrench	
MFH11-M05-01-3T	11	9.8	33	13.3	M05	3	LPGT010210...	TS2001	T6	
MFH13-M06-01-3T	13	11.5	34.5	14.5	M06	3				

MFH 03 高進給銑刀
HIGH FEED
MILLING CUTTER

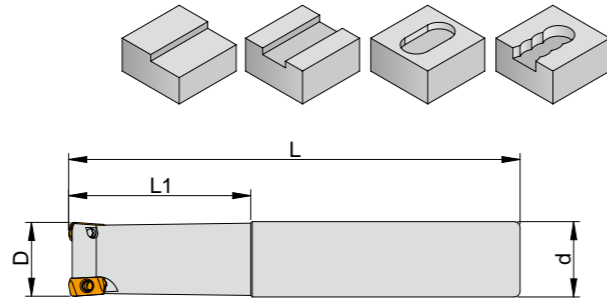

規格表 Specification

型號 Model	D	d	L	L1	T	刀片類型 Inserts	螺絲 Screw	板手 Wrench
MFH03-16-150-2T	16	16	150	30	2	LOGU030310ER	TS3004	T08
MFH03-17-150-2T	17			20				
MFH03-18-150-2T	18			20				
MFH03-20-150-3T	20	20	150	50	3			
MFH03-21-150-3T	21			30				
MFH03-22-150-3T	22	25	200	20	4			
MFH03-25-150-4T	25			60				
MFH03-26-150-4T	26			35				
MFH03-26-200-4T	26	25	200	45	4			
MFH03-28-150-4T	28			20				
MFH03-28-150-5T	28	32	150	20	5			
MFH03-32-150-5T	32			70				
MFH03-33-200-5T	33			32				
MFH03-35-200-5T	35	20						

MFH 03 鎖牙式高進給銑刀
THREADED HIGH FEED
MILLING CUTTER

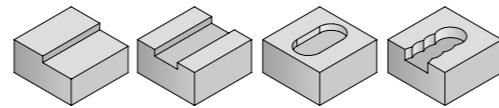

規格表 Specification

型號 Model	D	d	L	L1	M	T	刀片類型 Inserts	螺絲 Screw	板手 Wrench
MFH03-17-M08-2T-W	17	8.5	43	25	M08	2	LOGU030310ER	TS3004	T08
MFH03-21-M10-3T-W	21	10.5	49	30	M10				
MFH03-26-M12-4T-W	26	12.5	57	35	M12				
MFH03-35-M16-4T-W	35	17	63	40	M16				
MFH03-35-M16-5T-W					5				

MFH 10 高進給銑刀
HIGH FEED
MILLING CUTTER

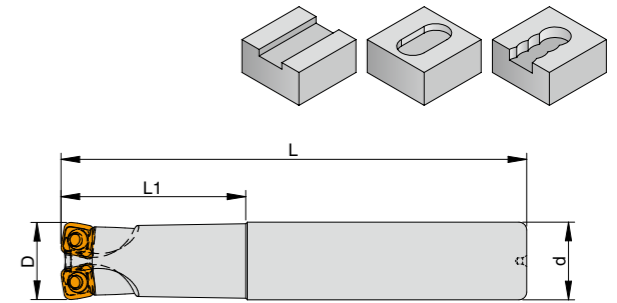

規格表 Specification

型號 Model	D	d	L	L1	T	刀片類型 Inserts	螺絲 Screw	板手 Wrench	
MFH10-25-150-2T	25	25	150	60	2	SOMT100420ER	TS4002	T15	
MFH10-26-200-2T	26		200	35					
MFH10-32-150-3T	32	32	150	70	3				
MFH10-35-150-2T	35		200	50					2
MFH10-35-200-2T			300						
MFH10-35-300-2T		150	3						
MFH10-35-150-3T									

MFH 10 鎖牙式高進給銑刀
THREADED HIGH FEED
MILLING CUTTER

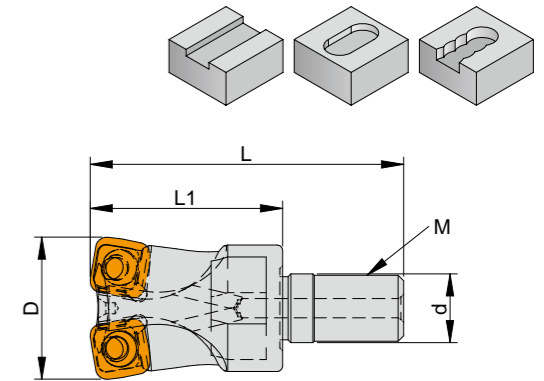

規格表 Specification

型號 Model	D	d	L	L1	M	T	刀片類型 Inserts	螺絲 Screw	板手 Wrench
MFH10-26-M12-2T-W	26	12.5	57	35	M12	2	SOMT100420ER	TS4002	T15
MFH10-32-M16-2T-W	32	16.5	63	40	M16				
MFH10-35-M16-3T-W	35								

MFH 10 殼型高進給銑刀
SHELL TYPE HIGH FEED
MILLING CUTTER

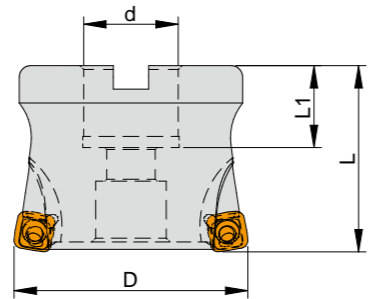
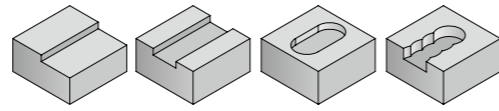

規格表 Specification

型號 Model	D	d	Dc	L	L1	T	刀片類型 Inserts	螺絲 Screw	板手 Wrench
MFH10-050-22-5T	50		47		21	5	SOMT100420ER	TS4004	T15
MFH10-063-22-5T		22		50					
MFH10-063-22-6T	63		60		25.4	6			
MFH10-063-25.4-6T		25.4							
MFH10-080-27-7T	80	27	76	63	24	7			
MFH10-080-31.75-7T		31.75			32				

Unit: mm

MEC 直角高速銑刀
ORTHOGONAL HIGH SPEED
MILLING CUTTER

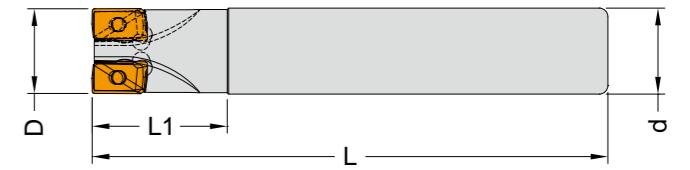
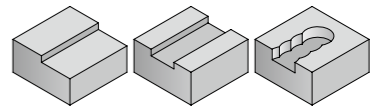

規格表 Specification

型號 Model	D	d	L1	L	T	刀片類型 Inserts	螺絲 Screw	板手 Wrench
MEC11R101-100L	10	12	25	100	1	BDMT11T3... BDGT11T3...	TS2516	T08
MEC11R121-100L	12	12	30	100	1			
MEC11R162-150L	16	16	35	150	2			
MEC11R182-150L	18	16	35	150	2			
MEC11R203-150L	20	20	40	150	3			
MEC11R253-150L	25	25	40	150	3			
MEC11R324-150L	32	32	40	150	4			
MEC11R405-150L	40	32	40	150	5			
MEC17R252-150L	25	25	40	150	2	BDMT1704... BDGT1704...	TS4002	T15
MEC17R323-150L	32	32	40	150	3			
MEC17R404-150L	40	32	40	150	4			

Unit: mm

MEC 鎖牙式高速銑刀
THREADED ORTHOGONAL
HIGH SPEED MILLING CUTTER

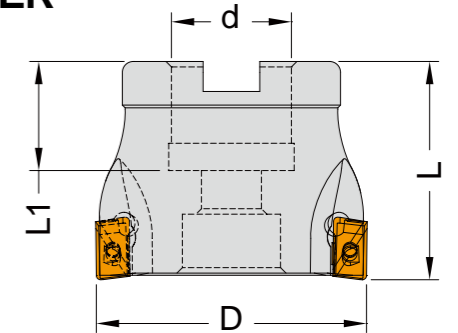
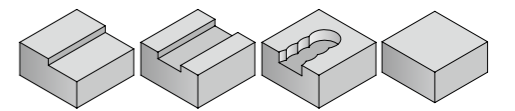

規格表 Specification

型號 Model	D	d	L1	L	T	刀片類型 Inserts	螺絲 Screw	板手 Wrench
MEC11R-05005-22	50	22	20	40	5	BDMT11T3... BDGT11T3...	TS2513	T08
MEC11R-06306-22	63	22	22	50	6			
MEC11R-08007-27	80	27	23	50	7			
MEC11R-10009-32	100	32	25	63	9			
MEC17R-05004-22	50	22	20	40	4	BDMT1704... BDGT1704...	TS4002	T15
MEC17R-06305-22	63	22	22	50	5			
MEC17R-08006-27	80	27	23	50	6			
MEC17R-10007-32	100	32	25	63	7			

Unit: mm

TFE 殼型輕量化銑刀
SHELL TYPE LIGHT DUTY
MILLING CUTTER

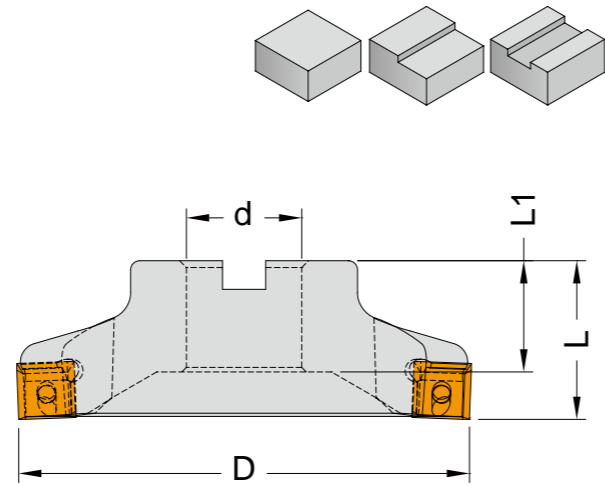

規格表 Specification Unit: mm

型號 Model	D	d	L1	L	T	刀片類型 Inserts	螺絲 Screw	板手 Wrench
TFE-06304R-22.0	63	22	21	35	4	SEGW12X...	TS4023	T15
TFE-08005R-25.4	80	25.4	25		5			
TFE-10006R-25.4	100	25.4	25		6			
TFE-12506R-25.4	125	25.4	25		6			

EXN03 高速直角銑刀
ORTHOGONAL HIGH SPEED
MILLING CUTTER

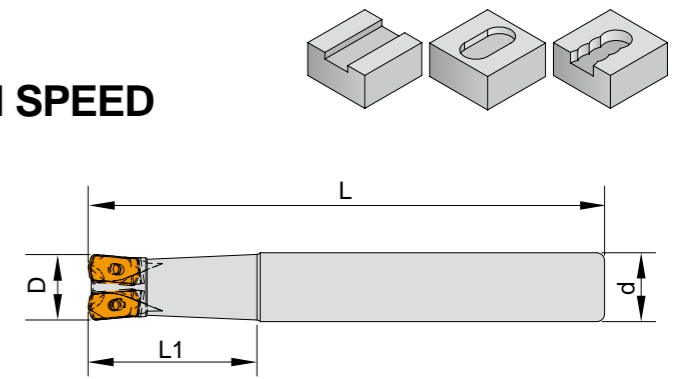

規格表 Specification Unit: mm

型號 Model	D	d	L1	L	T	刀片類型 Inserts	螺絲 Screw	板手 Wrench
EXN03R015M16-100	15	16	30	100	2	LNMU0303ZER-MJ	TS2511	T08
EXN03R016M16-120	16		40	120				
EXN03R016M16-160	16		40	160				
EXN03R017M16-120	17		30	120				
EXN03R017M16-150	17		30	150				
EXN03R018M16-120	18	40	120					
EXN03R020M20-130	20	20	40	130	3			
EXN03R021M20-130	21		50	130				
EXN03R021M20-170	21		50	170				
EXN03R025M25-150	25	25	60	150	3			
EXN03R026M25-150	26		60	150				
EXN03R026M25-200	26		60	200				
EXN03R035M32-220	35	32	60	220	4			
EXN03R035M32-250	35		60	250				
EXN03R032M32-150	32		45	150				

EXN03 鎖牙式高速直角銑刀
THREADED ORTHOGONAL HIGH
SPEED MILLING CUTTER

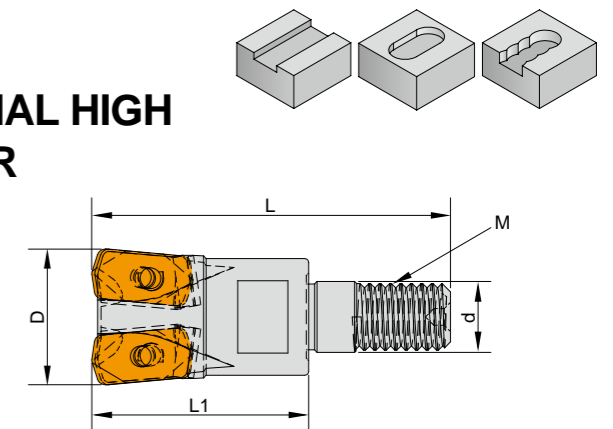

規格表 Specification Unit: mm

型號 Model	D	d	L1	L	M	刀片類型 Inserts	螺絲 Screw	板手 Wrench
EXN03R017-M08-2T	17	8.5	26	43	M08	LNMU0303ZER-MJ	TS2511	T08
EXN03R021-M10-3T	21	8.5	30	49	M10			
EXN03R026-M12-3T	26	8.5	35	57	M12			
EXN03R035-M16-4T	35	8.5	43	66	M16			

EPA 高速銑刀
HIGH SPEED
MILLING CUTTER

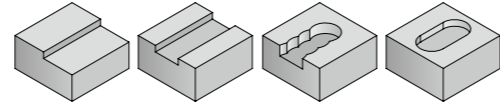

規格表 Specification		Unit: mm						
型號 Model	D	d	L	L1	T	刀片 Insert	螺絲 Screw	扳手 Wrench
EPA06R017M16-02-120	17	16	120	30	2	TXMU060308...	TS2502	T08
EPA06R021M20-03-130	21	20	130	30	3			

EVPA 直角高速銑刀
ORTHOGONAL HIGH SPEED
MILLING CUTTER

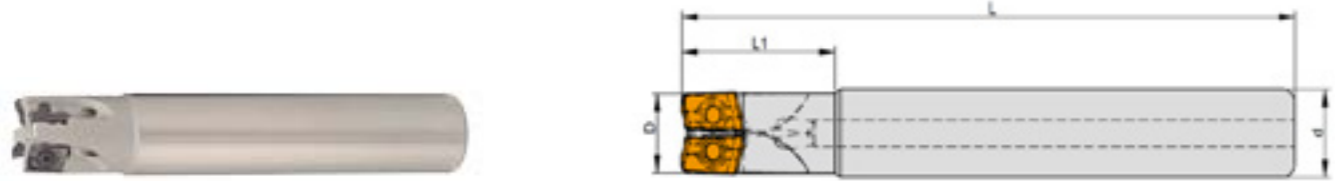
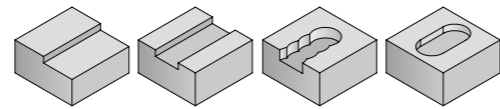

規格表 Specification		Unit: mm						
型號 Model	D	d	L	L1	T	刀片 Insert	螺絲 Screw	扳手 Wrench
EPAV06M010C12.0R02	10	12	80	20	2	AVGT060304...	TS2001	T6
EPAV06M012C12.0R03	12	12	80	20	3		TS2003	
EPAV06M016C16.0R04	16	16	90	20	4			

HFWX 高速銑刀
HIGH SPEED
MILLING CUTTER

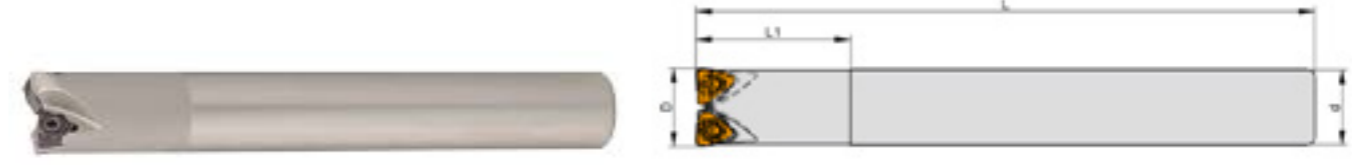
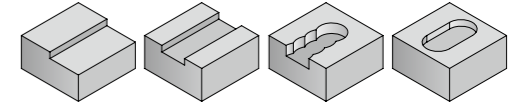

規格表 Specification		Unit: mm						
型號 Model	D	d	L	L1	T	刀片 Insert	螺絲 Screw	扳手 Wrench
HFWX04D017M16R02-120	17	16	120	30	2	WXHU040310...	TS2511	T08
HFWX04D021M20R03-130	21	20	130	30	3			

HFWX 鎖牙式高速銑刀
THREADED HIGH SPEED
MILLING CUTTER

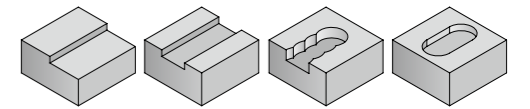

規格表 Specification		Unit: mm							
型號 Model	D	d	L	L1	M	T	刀片 Insert	螺絲 Screw	扳手 Wrench
HFWX04M017M08R02	17	15.9	43	17	M08	2	WXHU040310...	TS2511	T08
HFWX04M021M10R03	21	19.5	49	19	M10	3			
HFWX04M026M12R04	26	24	55	22	M12	4			
HFWX04M035M16R04	35	32	60	23	M16	4			

RT07, 10

**鎖牙式直角高速銑刀
THREADED ORTHOGONAL
HIGH SPEED MILLING CUTTER**

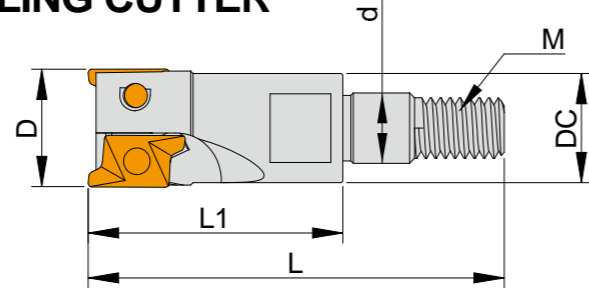
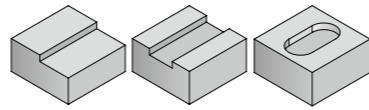

規格表 Specification

Unit: mm

型號 Model	D	d	L1	L	T	刀片類型 Inserts	螺絲 Screw	板手 Wrench
RT07-10-2T-M05	10	5.5	18	31	2	RT070204	TS2003	T06
RT07-11-2T-M05	11	5.5	18	31				
RT07-12-2T-M06	12	6.5	20	34				
RT07-13-2T-M06	13	6.5	20	34				
RT10-17-2T-M08	17	25	30	47	3	RT100308	TS2518	T08
RT10-21-3T-M10	21	32	30	49				
RT10-26-3T-M12	26	20	40	57				
RT10-33-4T-M16	33	25	40	63				
RT10-35-4T-M16	35	32	40	63	4			

RT07, 10

**直角高速銑刀
ORTHOGONAL HIGH SPEED
MILLING CUTTER**

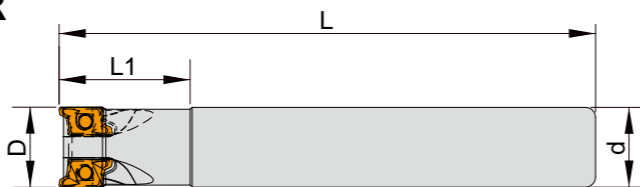
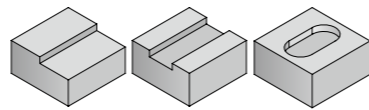

規格表 Specification

Unit: mm

型號 Model	D	d	L1	L	T	刀片類型 Inserts	螺絲 Screw	板手 Wrench
RT07-11-2T-100	11	10	18	100	2	RT070204	TS2003	T06
RT07-13-2T-100	13	12	20	100				
RT10-17-2T-150	17	16	30	150	3	RT100308	TS2518	T08
RT10-21-3T-150	21	20	30	150				
RT10-26-3T-150	26	25	40	150				
RT10-33-4T-150	33	32	40	150				
RT10-35-4T-150	35	32	40	150	4			

ASD90

**定位倒角刀
POSITIONING & CHAMFERRING
CUTTER**

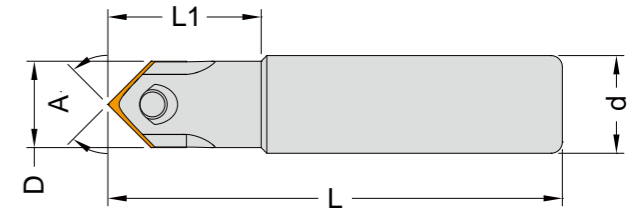

規格表 Specification

Unit: mm

型號 Model	D	d	L1	L	A	刀片類型 Inserts	螺絲 Screw	板手 Wrench
ASD90-12-130	12	12	30	130	90	A9012	B06R	T20
ASD90-16-150	16	16	35	150	90	A9016	B08R	T20

ASD120

**定位倒角刀
POSITIONING & CHAMFERRING
CUTTER**

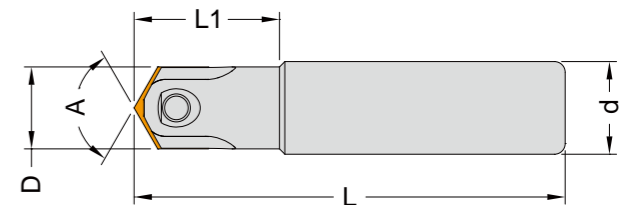

規格表 Specification

Unit: mm

型號 Model	D	d	L1	L	A	刀片類型 Inserts	螺絲 Screw	板手 Wrench
ASD120-12-130	12	12	30	130	120	A12012	B06R	T20
ASD120-16-150	16	16	35	150	120	A16016	B08R	T20

BJ16 替換式搪孔刀柄
INTERCHANGEABLE BORING BAR

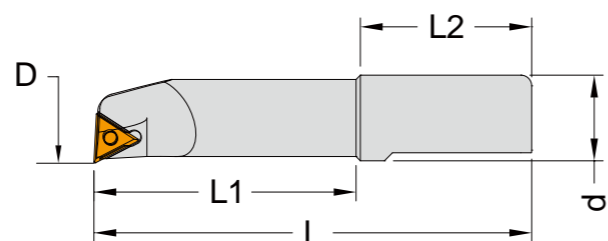
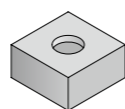

規格表 Specification

Unit: mm

型號 Model	D	d	L1	L2	L	刀片類型 Inserts	螺絲 Screw	板手 Wrench
BJ16-08-32	8	16	32	32	86	TBGT060104L	TS2003	T06
BJ16-10-40	10	16	40	32	80			
BJ16-12-53	12	16	53	32	85			
BJ16-16-68	16	16	68	32	100	TBGT090204L	TS2515	T08
BJ16-20-83	20	16	83	32	115	TBGT110304L	TS3005	T10
BJ16-25-90	25	16	90	32	122			
BJ16-30-90	30	16	90	32	122			
BJ16-40-90	40	16	90	32	122			

BJ20 替換式搪孔刀柄
INTERCHANGEABLE BORING BAR

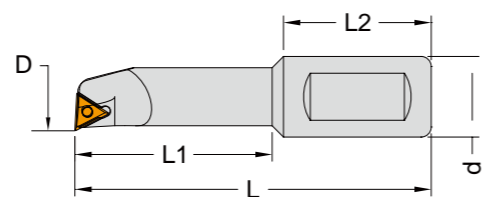
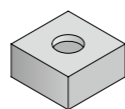

規格表 Specification

Unit: mm

型號 Model	D	d	L1	L2	L	刀片類型 Inserts	螺絲 Screw	板手 Wrench
BJ20-08-32	8	20	32	32	80	TBMT060104...	TS2003	T06
BJ20-10-40	10	20	40	32	80	TBGT060104...		
BJ20-12-53	12	20	53	32	85	TPGH090204...	TS2515	T08
BJ20-16-68	16	20	68	32	100			
BJ20-20-83	20	20	83	32	115	TPMT110304... TBGH110304...	TS3005	T10
BJ20-25-96	25	20	96	32	135			
BJ20-30-115	30	20	115	32	154			
BJ20-35-97-L	35	20	14	-	99			

TBB 替換式搪刀柄
REPLACEABLE BORING BAR

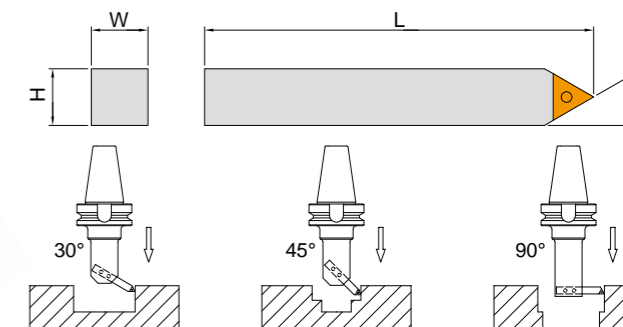

規格表 Specification

Unit: mm

型號 Model	H	W	L	A	刀片類型 Inserts	螺絲 Screw	板手 Wrench
TBB-908-055L	8	8	55	90°	TPGH090204	TS2515	T08
TBB-910-065L	10	10	65		TPGH110304	TS3005	T15
TBB-913-080L	13	13	80				
TBB-916-120L	16	16	120		TPGH1603..	TS4009	T20
TBB-919-140L	19	20	140				
TBB-925-150L	25	25	150				
TBB-308-055L	8	8	55	30°	TPGH090204	TS2515	T08
TBB-310-065L	10	10	65		TPGH110304	TS3005	T15
TBB-313-080L	13	13	80				
TBB-316-120L	16	16	120		TPGH1603..	TS4009	T20
TBB-319-140L	19	20	140				
TBB-325-150L	25	25	150				
TBB-408-055L	8	8	55	45°	TPGH090204	TS2515	T08
TBB-410-065L	10	10	65		TPGH110304	TS3005	T15
TBB-413-080L	13	13	80				
TBB-416-120L	16	16	120		TPGH1603..	TS4009	T20
TBB-419-140L	19	20	140				
TBB-425-150L	25	25	150				

CBB 替換式搪刀柄 REPLACEABLE BORING BAR

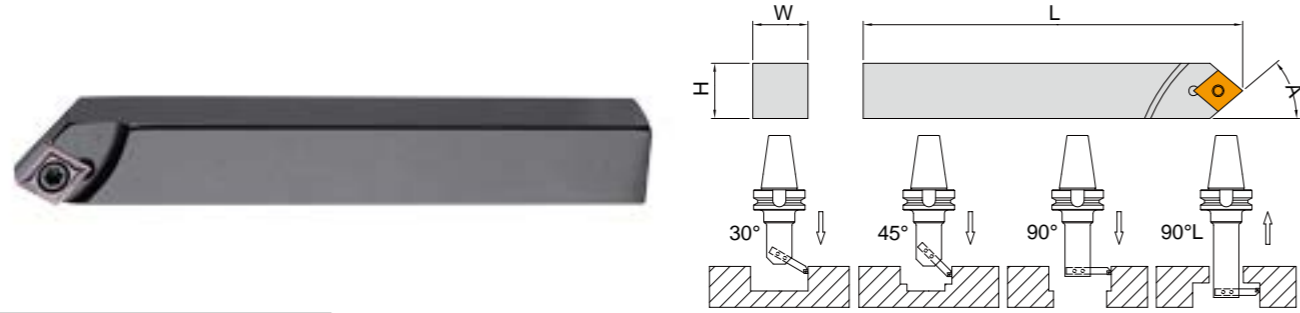

規格表 Specification

型號 Model	H	W	L	A	刀片類型 Inserts	螺絲 Screw	板手 Wrench	
CBB-908-055L	8	8	55	90°	CCMT060204	TS2515	T08	
CBB-910-065L	10	10	65		CCMT09T304	TS4004	T15	
CBB-913-080L	13	13	80		CCMT120408	TS5007	T20	
CBB-916-120L	16	16	120		30°	CCMT060204	TS2507	T08
CBB-919-140L	19	20	140			CCMT09T304	TS4004	T15
CBB-925-150L	25	25	150			CCMT120408	TS5007	T20
CBB-308-055L	8	8	55	45°		CCMT060204	TS2515	T08
CBB-310-065L	10	10	65		CCMT09T304	TS4004	T15	
CBB-313-080L	13	13	80		CCMT120408	TS5007	T20	
CBB-316-120L	16	16	120		90°	CCMT060204	TS2515	T08
CBB-319-140L	19	20	140			CCMT09T304	TS4004	T15
CBB-325-150L	25	25	150	CCMT120408		TS5007	T20	

Unit: mm

C211 直角高速端銑刀 ORTHOGONAL HIGH SPEED END MILLING CUTTER

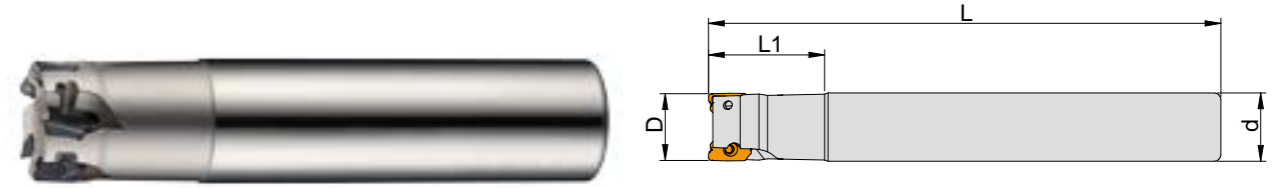
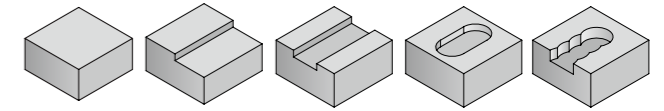

規格表 Specification

型號 Model	D	d	L1	L	T	刀片類型 Inserts	螺絲 Screw	板手 Wrench
C211.20R03-C20-150L-11	20	20	35	150	3	XD..11T3..	TS2515	T08
C211.25R04-C25-150L-11	25	25	45	150	4			
C211.32R04-C32-150L-11	32	32	45	150	4			
C211.32R05-C32-150L-11	32	32	45	150	5			

Unit: mm

ON05 殼型八角型銑刀
SHELL TYPE OCTAGON MILLING CUTTER

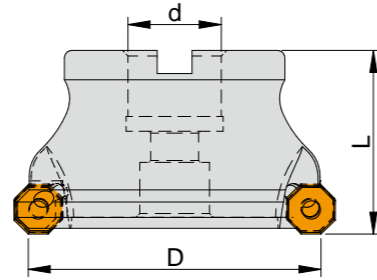
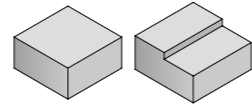

規格表 Specification

Unit: mm

型號 Model	D	d	L	T	刀片類型 Inserts	螺絲 Screw	板手 Wrench
ON05-05004R-25.4	50	25.4	45	4	ONMU0505	TS4015	T15
ON05-06305R-25.4	63	25.4	50	5			
ON05-08006R-25.4	80	25.4	50	6			
ON05-10007R-31.75	100	31.75	55	8			
ON05-12510R-38.1	125	38.1	63	10			
ON05-16012R-50.8	160	50.8		12			
ON05-06305L-25.4	100	25.4	50	5			
ON05-08006L-25.4	125	25.4	50	6			

ASP415R 殼型銑刀
SHELL TYPE MILLING CUTTER

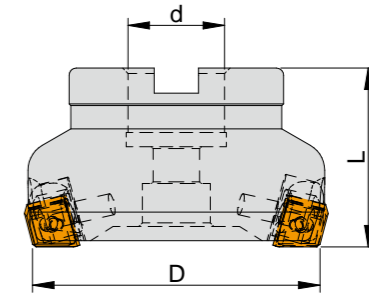
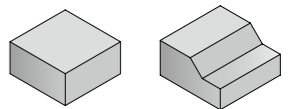

規格表 Specification

Unit: mm

型號	D	d	L	T	刀片類型	品名	雙頭螺絲	墊片螺絲	壓板
ASP415R-03-05T	80	25.4	50	5	SEKN1204EDR	圖樣			
ASP415R-04-05T	100	31.75	50	5		型號	SP-M817	SP-M406	SP-M8L
ASP415R-05-06T	125	38.1	55	6		品名	墊片	板手	
ASP415R-06-08T	160	50.8	63	8		圖樣			
ASP415R-08-10T	200	47.625	63	10		型號	SP-M40	TL-4	
ASP415R-10-12T	250	47.625	63	12					
ASP415R-12-14T	305	47.625	63	14					

ASP415R 殼型多刃銑刀
SHELL TYPE MULTI-INSERT MILLING CUTTER

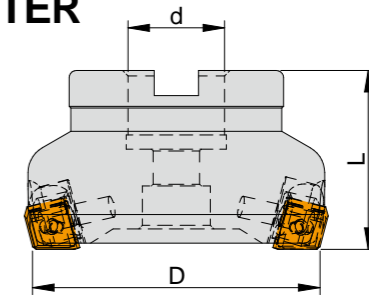
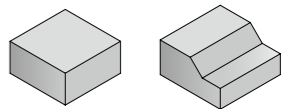

規格表 Specification

Unit: mm

型號	D	d	L	T	刀片類型	品名	雙頭螺絲	墊片螺絲	壓板
ASP415R-080-08T	80	27	50	8	SP1203EDR	圖樣			
ASP415R-100-10T	100	32	50	10		型號	SP-M616	TS3006	SP-M6L
						品名	墊片	板手	
						圖樣			
						型號	415-M3	TK15	

ASP435R 殼型銑刀 SHELL TYPE MILLING CUTTER

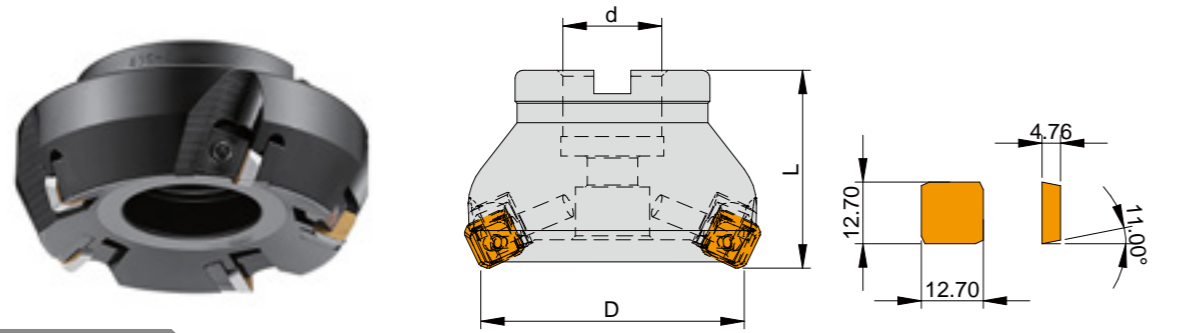

規格表 Specification

型號	D	d	L	T	刀片類型	品名	雙頭螺絲	墊片螺絲	壓板
ASP435R-03-05T	80	25.4	50	5	SEKN1204XFR SPK43C2SR	圖樣			
ASP435R-04-05T	100	31.75	50	5		型號	SP-M817	SP-M406	SP-M8L
ASP435R-05-06T	125	38.1	55	6		品名	墊片	扳手	
ASP435R-06-08T	160	50.8	63	8		圖樣			
ASP435R-08-10T	200	47.625	63	10		型號	SP-M40	TL-4	
ASP435R-10-12T	250	47.625	63	12					
ASP435R-12-14T	305	47.625	63	14					

ASP435R 殼型多刃銑刀 SHELL TYPE MULTI-INSERT MILLING CUTTER

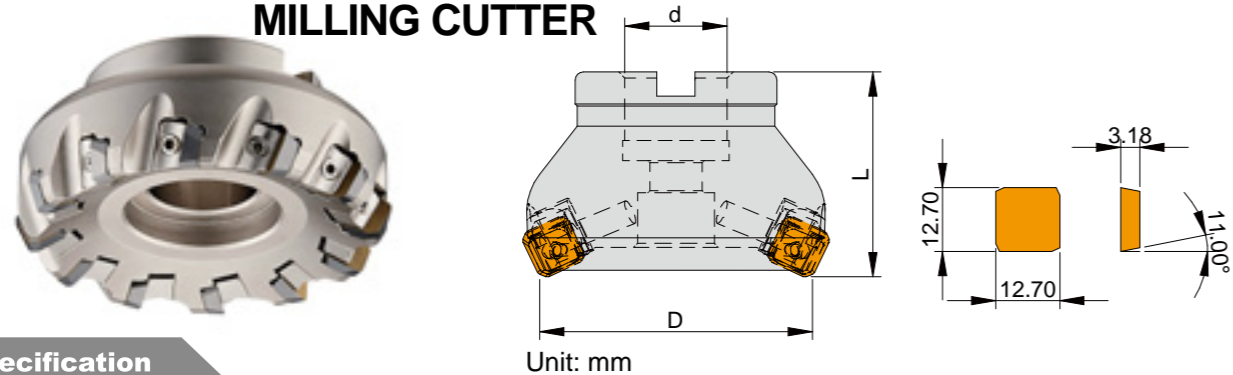

規格表 Specification

型號	D	d	L	T	刀片類型	品名	雙頭螺絲	壓板	扳手
ASP435R-63-6T	63	25.4	50	6	SEKN1203XER SPK43C2SR	圖樣			
ASP435R-80-8T	80	25.4	50	8		型號	SP-M616	SP-M6L	T15
ASP435R-100-12T	100	31.75	50	12					
ASP435R-125-14T	125	38.1	55	16					
ASP435R-160-18T	160	50.8	63	20					

ASE445R 殼型銑刀 SHELL TYPE MILLING CUTTER

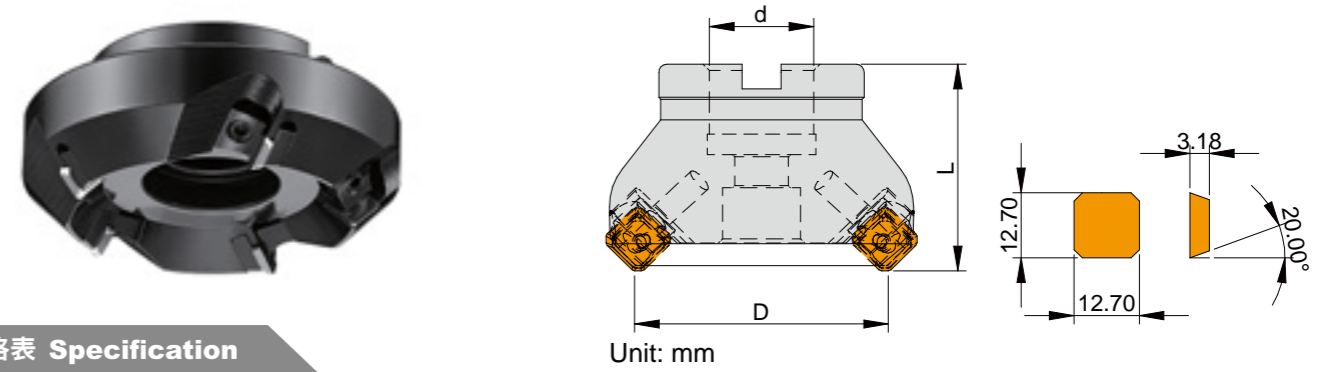

規格表 Specification

型號	D	d	L	T	刀片類型	品名	雙頭螺絲	墊片螺絲	壓板
ASE445R-03-05T	80	25.4	50	5	SEKN1203AFR	圖樣			
ASE445R-04-05T	100	31.75	50	5		型號	SP-M817	SP-M406	SP-M8L
ASE445R-05-06T	125	38.1	55	6		品名	墊片	扳手	
ASE445R-06-08T	160	50.8	63	8		圖樣			
ASE445R-08-10T	200	47.625	63	10		型號	SP-M40	TL-4	
ASE445R-10-12T	250	47.625	63	12					
ASE445R-12-14T	305	47.625	63	14					

ASE445R 殼型多刃銑刀 SHELL TYPE MULTI-INSERT MILLING CUTTER

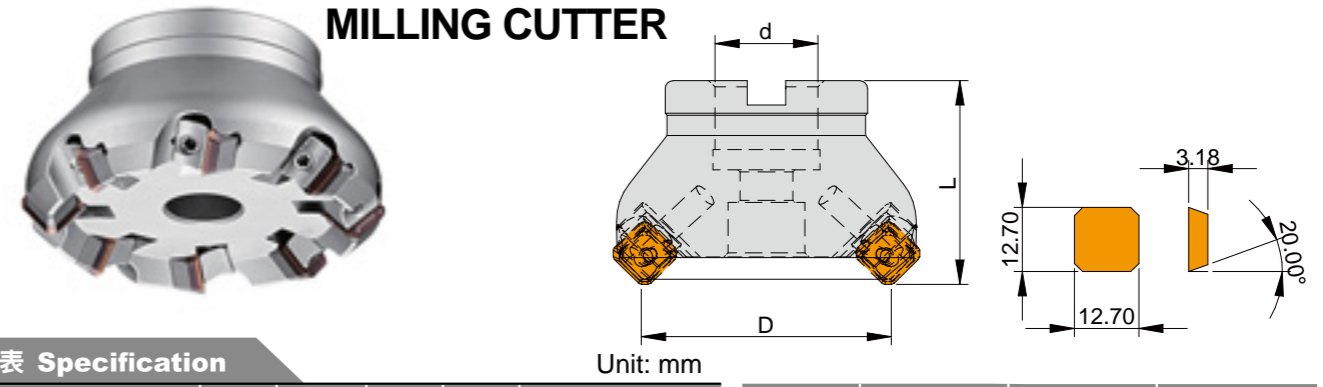

規格表 Specification

型號	D	d	L	T	刀片類型	品名	雙頭螺絲	墊片螺絲	壓板
ASE445R-063-06T	63	25.4	50	6	SEKN1203AFR	圖樣			
ASE445R-080-08T	80	25.4	50	8		型號	SP-M616	TS3006	SP-M6L
ASE445R-100-10T	100	32	50	10					
						品名	墊片	扳手	
						圖樣			
						型號	445-M3	T15	

ASP535 殼型銑刀 SHELL TYPE MILLING CUTTER

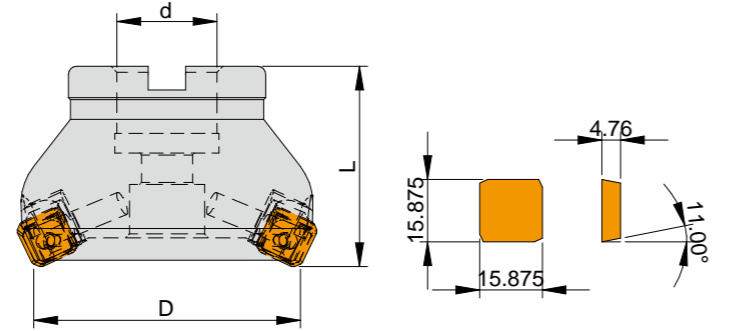

規格表 Specification

型號	D	d	L	T	刀片類型	品名	雙頭螺絲	墊片螺絲	壓板
ASP535R-03-05T	80	25.4	50	5	SEKN1504XER SPK53C2SR	圖樣			
ASP535R-04-05T	100	31.75	50	5		型號	SP-M817	SP-M406	SP-M8L
ASP535R-05-06T	125	38.1	55	6		品名	墊片	扳手	
ASP535R-06-08T	160	50.8	63	8		圖樣			
ASP535R-08-10T	200	47.625	63	10		型號	SP-M40	TL-4	
ASP535R-10-12T	250	47.625	63	12					
ASP535R-12-14T	305	47.625	63	14					

Unit: mm

ASE545 殼型銑刀 SHELL TYPE MILLING CUTTER

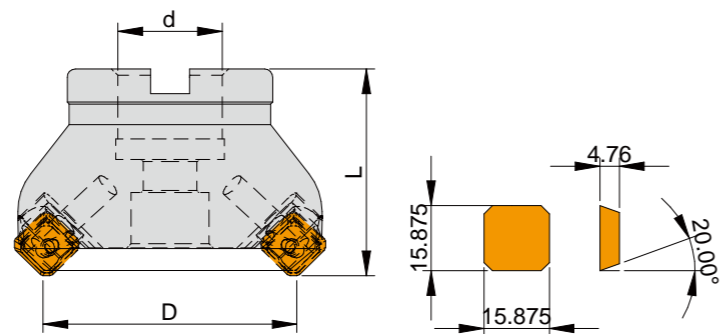
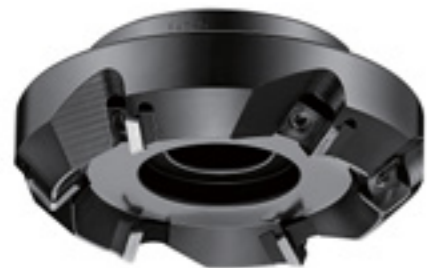

規格表 Specification

型號	D	d	L	T	刀片類型	品名	雙頭螺絲	墊片螺絲	壓板
ASE545R-03-05T	80	25.4	50	5	SEKN1504AFR	圖樣			
ASE545R-04-05T	100	31.75	50	5		型號	SP-M817	SP-M406	SP-M8L
ASE545R-05-06T	125	38.1	55	6		品名	墊片	扳手	
ASE545R-06-08T	160	50.8	63	8		圖樣			
ASE545R-08-10T	200	47.625	63	10		型號	SP-M40	TL-4	
ASE545R-10-12T	250	47.625	63	12					
ASE545R-12-14T	305	47.625	63	14					

Unit: mm

NSE400R 殼型直角面銑刀 SHELL TYPE ORTHOGNAL FACE MILLING CUTTER

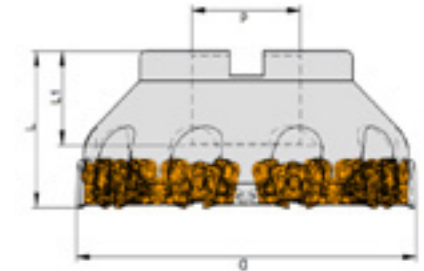

規格表 Specification

型號 Model	D	d	L1	L2	T	刀片類型 Inserts	螺絲 Screw	扳手 Wrench
NSE400R0407-31.75	100	31.75	50	28	7	TECN2204PECN	TS3007	T10
NSE400R0407-32	100	32	50	28	7			
NSE400R0508-38.1	125	38.1	63	38	8			
NSE400R0508-40	125	40	63	38	8			
NSE400R0610-50.8	160	50.8	63	38	10			
NSE400R0610-40	160	40	63	38	10			
NSE400R0814-47.625	200	47.625	63	40	14			
NSE400R0814-60	200	60	63	40	14			

Unit: mm

刀座 Tool Holder	壓板 Pressure Plate	雙頭螺絲 Double Screw	扳手 Wrench
NSE400R-G02	NSE400R-G01	GCS718-1	T20

HCN07 高進給銑刀
HIGH FEED SPEED
MILLING CUTTER

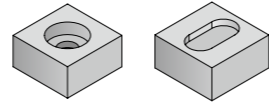

規格表 Specification Unit: mm

型號 Model	D	d	L	L1	T	刀片 Insert	螺絲 Screw	板手 Wrench
HCN07-1602-C16-150	16	16	150	35	2	CNGX07...	TS2511	T8
HCN07-1702-C16-150	17	16	150	30	2			
HCN07-2003-C20-150	20	20	150	40	3			
HCN07-2103-C20-150	21	20	150	30	3			

HHN 多角平面銑刀
MULTI-ANGLE FACE
MILL CUTTER

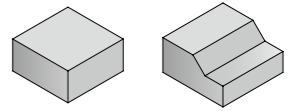

規格表 Specification Unit: mm

型號 Model	D	L1	d	L	T	刀片 Insert	螺絲 Screw	板手 Wrench
HHN06-2502-S25-150	25	34	25	150	2	HNGX0604...	TS3007	T10
HHN06-2503-S25-150	25	34	25	150	3			
HHN06-3203-S32-150	32	41	32	150	3			
HHN06-3204-S32-150	32	41	32	150	2			

HCN07 鎖牙式高進給銑刀
TREADED HIGH FEED
SPEED MILLING CUTTER

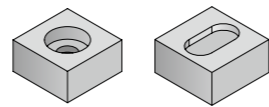

規格表 Specification Unit: mm

型號 Model	D	d	L	L1	M	T	刀片 Insert	螺絲 Screw	板手 Wrench
HCN07-1702-M08	17	14	43	17	M08	2	CNGX07...	TS2511	T8
HCN07-2103-M10	21	18	50	19	M10	3			
HCN07-2604-M12	26	23	57	22	M12	4			

PHN 殼型多角平面銑刀
MULTI-ANGLE FACE MILLING CUTTER

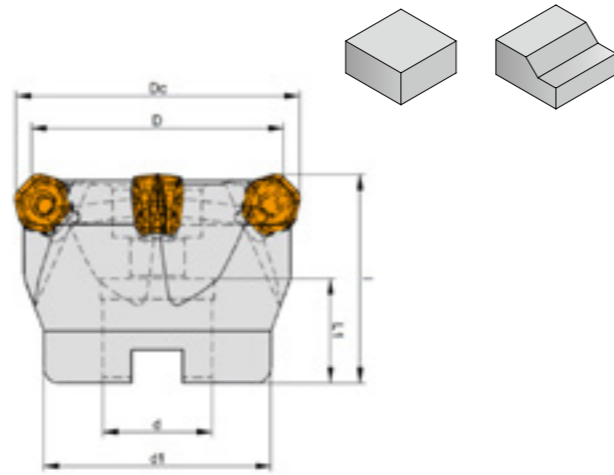

規格表 Specification

型號 Model	D	Dc	d	d1	L	L1	T	刀片 Insert	螺絲 Screw	板手 Wrench
PHN06-04005-16	40	48.1	16	35	40	18	5	HNGX0604...	TS3007	T10
PHN06-05004-22	50	58.1	22	46	40	20	4			
PHN06-05006-22	50	58.1	22	46	40	20	6			
PHN06-06306-22	63	71.1	22	55	40	20	6			
PHN06-06308-22	63	71.1	22	55	40	20	8			
PHN06-08007-27	80	88.1	27	60	50	25.4	7			
PHN06-08010-27	80	88.1	27	60	50	25.4	10	HNGX0604...	TS4006	T15
PHN09-05004-22	50	63	22	42	40	20	4			
PHN09-06306-22	63	76	22	55	40	20	6			
PHN09-08006-27	80	93	27	60	50	25.4	6			
PHN09-08008-27	80	93	27	60	50	25.4	8			
PHN09-10008-32	100	113	32	74	50	28	8			
PHN09-10010-32	100	113	32	74	50	28	10			
PHN09-12508-40	125	133	40	74	50	28	8			
PHN09-12510-40	125	133	40	74	50	28	10			

Unit: mm

直角高速銑刀
ORTHOGONAL HIGH SPEED SHOLDER MILLING CUTTER

VSM11



規格表 Specification

型號 Model	D	d	L	L1	T	刀片 Insert	螺絲 Screw	板手 Wrench
VSM11D016Z02A16XD11L150	16	16	150	25	2	XDPT110408..	TS2515	T08
VSM11D020Z03A20XD11L150	20	20	150	25	3			

Unit: mm

VSM490



規格表 Specification

型號 Model	D	d	L	L1	T	刀片 Insert	螺絲 Screw	板手 Wrench
VSM490D025Z02A25XN15L170	25	25	170	40	2	XNGU15T615..	TS4004	TS4004

Unit: mm

VSM490



規格表 Specification

型號 Model	D	d	Dc	L	L1	T	刀片 Insert	螺絲 Screw	板手 Wrench
VSM490D050Z04S254XN15	50	25.4	42	40	21	4	XNGU15T615..	TS4004	T15
VSM490D063Z05S254XN15	63	25.4	50	40	21	5			
VSM490D063Z06S254XN15	63	25.4	50	40	21	6			

Unit: mm

KHD 鎢鋼抗振接桿
TUNGSTEN CABIDE CONNECTION ROD

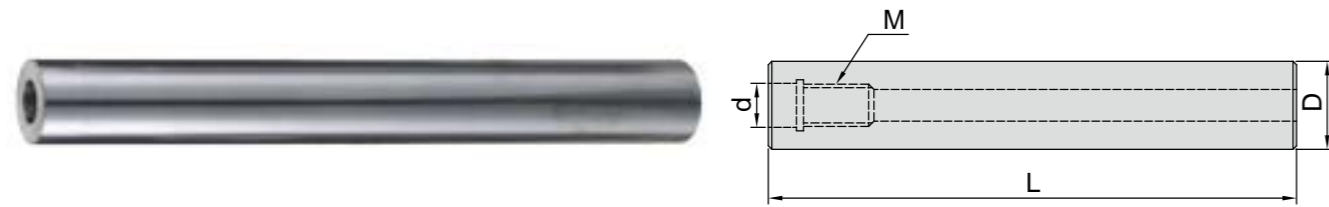

規格表 Specification

Unit: mm

型號 Model	D	M	L	d
KHD08-060-M04	8	M4	60	4.5
KHD08-120-M04	8	M4	120	4.5
KHD10-075-M05	10	M5	75	5.5
KHD10-100-M05	10	M5	100	5.5
KHD10-150-M05	10	M5	150	5.5
KHD12-100-M06	12	M6	100	6.5
KHD12-150-M06	12	M6	150	6.5
KHD12-200-M06	12	M6	200	6.5
KHD16-100-M08	16	M8	100	8.5
KHD16-150-M08	16	M8	150	8.5
KHD16-200-M08	16	M8	200	8.5
KHD16-250-M08	16	M8	250	8.5
KHD20-100-M10	20	M10	100	10.5
KHD20-150-M10	20	M10	150	10.5
KHD20-200-M10	20	M10	200	10.5
KHD20-250-M10	20	M10	250	10.5
KHD25-100-M12	25	M12	100	12.5
KHD25-150-M12	25	M12	150	12.5
KHD25-200-M12	25	M12	200	12.5
KHD25-250-M12	25	M12	250	12.5
KHD32-150-M16	32	M16	150	17
KHD32-200-M16	32	M16	200	17
KHD32-250-M16	32	M16	250	17
KHD32-300-M16	32	M16	300	17
KHD32-350-M16	32	M16	350	17
KHD32-400-M16	32	M16	400	17

KMC 連接式合金鋼接桿
TUNGSTEN CABIDE CONNECTION ROD

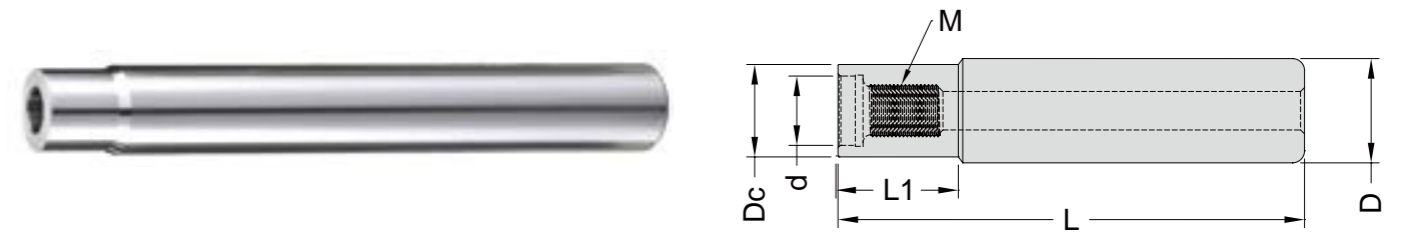

規格表 Specification

Unit: mm

型號 Model	D	Dc	d	L	L1	M
KMC16-075-M08	16	15	8.5	75	30	M08
KMC16-100-M08	16	15	8.5	100		M08
KMC16-150-M08	16	15	8.5	150		M08
KMC20-100-M10	20	18	10.5	100		M10
KMC20-150-M10	20	18	10.5	150		M10
KMC20-200-M10	20	18	10.5	200		M10
KMC25-100-M12	25	23	12.5	100		M12
KMC25-150-M12	25	23	12.5	150		M12
KMC25-200-M12	25	23	12.5	200		M12
KMC32-250-M12	32	23	12.5	250		M12
KMC32-100-M16	32	30	17	100		M16
KMC32-150-M16	32	30	17	150		M16
KMC32-200-M16	32	30	17	200		M16
KMC32-250-M16	32	30	17	250		M16
KMC42-300-M16	42	30	17	300		M16

BT 鎖牙接桿 ARBOR

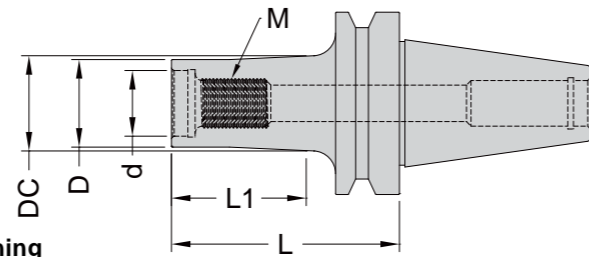

for neck section, additional machining to user specifications is possible

規格表 Specification

Unit: mm

型號 Model	D	Dc	d	L1	L	M
BT30-FMC12-12-50	11	12	6.5	12	50	M06
BT30-FMC16-16-50	15	16	8.5	16	50	M08
BT30-FMC20-05-40	18	20	10.5	5	40	M10
BT30-FMC20-20-50	18	20	10.5	20	50	M10
BT30-FMC25-05-40	23	25	12.5	5	40	M12
BT30-FMC25-28-55	23	25	12.5	28	55	M12
BT30-FMC32-28-55	30	32	17	28	55	M16
BT40-FMC12-12-62	11	12	6.5	12	62	M06
BT40-FMC16-16-62	15	16	8.5	16	62	M08
BT40-FMC16-32-75	15	16	8.5	32	75	M08
BT40-FMC20-05-50	18	20	10.5	5	50	M10
BT40-FMC20-50-87	18	20	10.5	50	87	M10
BT40-FMC25-05-50	18	25	10.5	5	50	M10
BT40-FMC25-25-60	18	25	10.5	25	60	M10
BT40-FMC25-30-67	25	25	12.5	30	67	M12
BT40-FMC25-50-87	25	25	12.5	50	87	M12
BT40-FMC32-30-62	30	32	17	30	62	M16
BT40-FMC32-50-87	30	32	17	50	87	M16
BT40-FMC40-50-87	36	40	28	50	87	M18
BT40-FMC40-90-127	36	40	28	90	127	M18

BT 鎖牙接桿 ARBOR

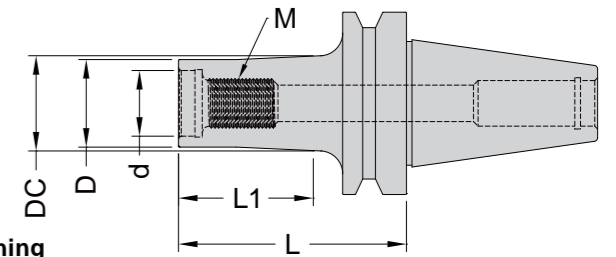

for neck section, additional machining to user specifications is possible

規格表 Specification

Unit: mm

型號 Model	D	Dc	d	L1	L	M
BT50-FMC12-12-87	11	12	6.5	12	87	M06
BT50-FMC16-16-87	15	16	8.5	16	87	M08
BT50-FMC16-32-87	15	16	8.5	32	87	M08
BT50-FMC20-40-100	18	20	10.5	40	100	M10
BT50-FMC20-60-125	18	20	10.5	60	125	M10
BT50-FMC25-25-87	25	25	12.5	25	87	M12
BT50-FMC25-50-125	25	25	12.5	50	125	M12
BT50-FMC32-30-87	30	32	17	30	87	M16
BT50-FMC32-60-125	30	32	17	60	125	M16
BT50-FMC40-35-85	36	40	28	40	87	M18
BT50-FMC40-75-125	36	40	28	75	125	M18
BT50-FMC50-030-78	48	50	36	30	78	M25
BT50-FMC50-080-115	48	50	36	80	115	M25
BT50-FMC50-130-165	48	50	36	130	165	M25
BT50-FMC50-180-215	48	50	36	180	215	M25
BT50-FMC50-230-265	48	50	36	230	265	M25
BT50-FMC50-280-315	48	50	36	280	315	M25
BT50-FMC50-330-365	48	50	36	330	365	M25
BT50-FMC50-380-415	48	50	36	380	415	M25
BT50-FMC50-430-465	48	50	36	430	465	M25
BT50-FMC50-480-515	48	50	36	480	515	M25

卡式刀座 CARTRIDGES

SCFCR



MEET WITH ISO STD.

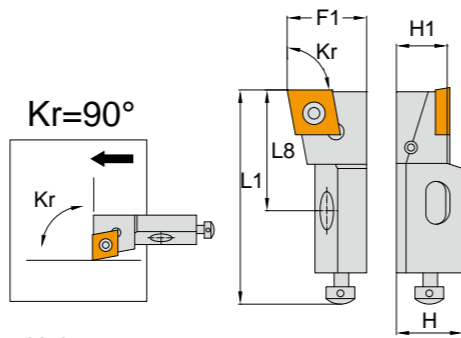

Unit: mm

規格表 Specification

型號 Model	L1	L8	F1	H1	H	Dm	刀片類型 Inserts
SCFCR-08CA-06	32	15	10	8	10	25	CC..0602..
SCFCR-10CA-09	50	30	14	10	15	40	CC..09T3..
SCFCR-12CA-09	55	35	20	12	20	50	

STFCR



MEET WITH ISO STD.

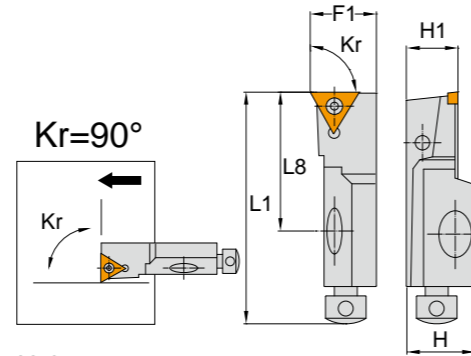

Unit: mm

規格表 Specification

型號 Model	L1	L8	F1	H1	H	Dm	刀片類型 Inserts
STFCR-08CA-09	32	15	10	8	10	25	TC..0902..
STFCR-10CA-11	50	30	14	10	15	40	TC..1102..
STFCR-12CA-16	55	35	20	12	20	50	TC..16T3..
STFCR-16CA-16	63	38	25	16	21	55	

STSCR



MEET WITH ISO STD.

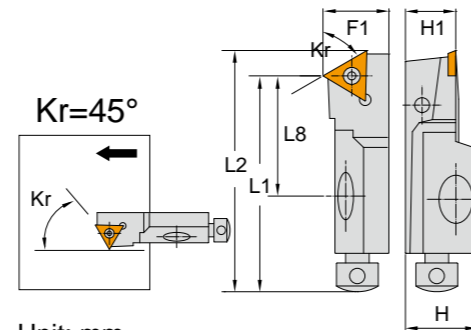

Unit: mm

規格表 Specification

型號 Model	L1	L2	L8	F1	H1	H	Dm	刀片類型 Inserts
STSCR-08CA-09	28	34.1	11	10	8	10	25	TC..0902..
STSCR-10CA-11	44	51	24	14	10	15	40	TC..1102..
STSCR-12CA-16	47	57	27	20	12	20	50	TC..16T3..
STSCR-16CA-16	53	63	28	25	16	21	55	

卡式刀座 CARTRIDGES

STWCR



MEET WITH ISO STD.

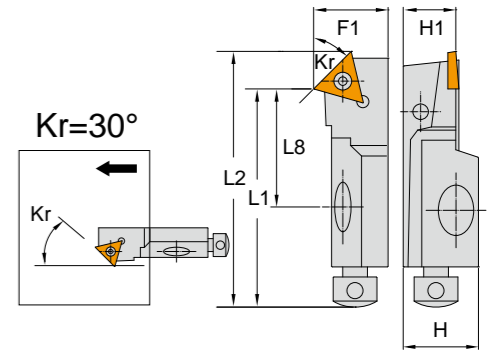

Unit: mm

規格表 Specification

型號 Model	L1	L2	L8	F1	H1	H	Dm	刀片類型 Inserts
STWCR-08CA-09	28	32	11	10	8	10	25	TC..0902..
STWCR-10CA-11	44	49	24	14	10	15	40	TC..1103..
STWCR-12CA-16	47	54	28	20	12	20	50	TC..1603..

STTCR



MEET WITH ISO STD.

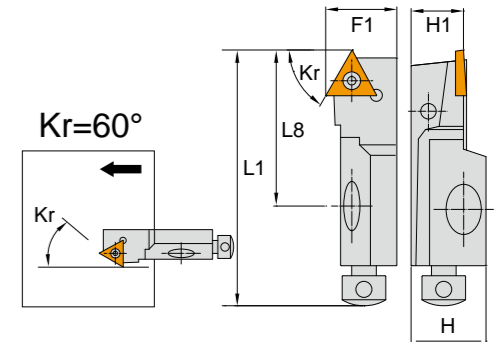

Unit: mm

規格表 Specification

型號 Model	L1	L8	F1	H1	H	Dm	刀片類型 Inserts
STTCR-08CA-09	32	15	6	8	10	25	TC..0902..
STTCR-10CA-11	50	30	9	10	15	40	TC..1103..
STTCR-12CA-16	55	35	13	12	20	50	TC..1603..
STTCR-16CA-16	63	38	15	16	21	60	

EB 捨棄式搪孔刀
DISPOSABLE BORING MILLING CUTTER

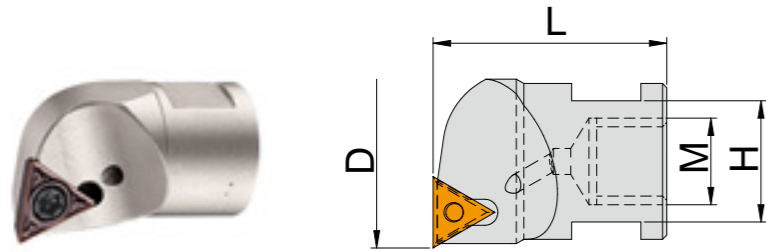

規格表 Specification

Unit: mm

型號 Model	D		L1	M	刀片類型 Inserts	螺絲 Screw	板手 Wrench
	Min.	Max.					
EB09N-TP08,TB06	9	10.5	18	M5	TB..0601	TS2003	T06
EB10.5N-TP08,TB06	10.5	12					
EB12N-TP08,TB09	12	14	23	M6	TPGT080204 TB..0802 TPGT090204	TS2507	T08
EB14N-TP08,TP09	14	16					
EB16N-TP08,TB09	16	18					
EB18N-TP08,TB09	18	20					
EB20N-TP08,TB09	20	22	27	M10	TPGT080204 TP..0802 TP..1103	TS2003 TS3005	T08 T10
EB22N-TP08,TB11	22	24					
EB24N-TP08,TB11	24	26					
EB26N-TP08,TB11	26	28					
EB28N-TP08,TB11	28	30					
EB30N-TP08,TB11	30	32					
EB32N-TP08,TB11	32	34					
EB34N-TP08,TB11	34	36					
EB36N-TP08,TB11	36	38					
EB38N-TP08,TB11	38	40					
EB40N-TP08,TB11	40	42					
EB42N-TP08,TB11	42	44					
EB44N-TP08,TB11	44	46					
EB46N-TP08,TB11	46	48					
EB48N-TP08,TB11	48	50					
EB50N-TP08,TB11	50	52					

SC 直束鎢鋼柄搪刀桿
STRAIGHT TUNGSTEN CARBIDE TOOL HOLDER



規格表 Specification

Unit: mm

型號 Model	D	M	L	適用套筒 Applicable Collet
SC08-M5-115	8	M5	115	EC1608
SC10-M6-115	10	M6	115	EC1610
SC10-M6-135			135	
SC10-M6-160			160	
SC12-M6-150	12	M6	150	EC1612
SC12-M6-165			165	
SC16-M10-110	16	M10	110	EC1612
SC16-M10-145			145	
SC16-M10-180			180	

NOTE

Lined writing area for page 166.

NOTE

Lined writing area for page 167.

NOTE

A series of horizontal dotted lines for writing notes.



鐸豐富企業有限公司
DOW FENG FUH ENTERPRICE CO., LTD.

台中市大甲區重義一路155號
No. 155, Chongyi 1st Rd., ajia Dist., Taichung City
43743, Taiwan
TEL : 886-4-2676-5135
FAX : 886-4-2676-5137
E-MAIL : dff@seed.net.tw



由於本公司不斷研究改良，上述規格及設計特性若有變更，恕不另行通知。

Specifications and design characteristics are subject to change without prior notice.